

TECHNOSKLO Ltd.

Držkov

Distillation apparatus for producing of
distilled water
TYPE DP 4000

Operating manual

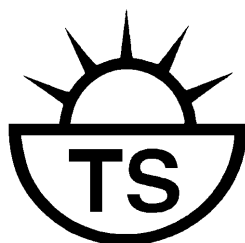

TECHNOSKLO Ltd.
Držkov 135
468 24 Držkov
Czech Republic
tel.: 00420 483 346 403
fax: 00420 483 385 040
Skype: miroslav.bruna
e-mail: sales@technosklo.com
<http://www.technosklo.com>

Content

Page

I. Description of the apparatus	3
II. Technical data.....	3
III. General Instructions and safety regulations	3
IV. Connection to the Electrical Mains/Water Supply	4
V. Picture of the apparatus	5
VI. Unpacking the apparatus.....	6
VII. Setting up the apparatus.....	6
VIII. Installing of the Reservoir Bottle.....	6
IX. Protective cap	6
X. Connecting of the Tubing	7
Connecting of the cooling water supply.....	7
Connecting of the water drainage.....	7
Connecting of the outlet valve.....	7
XI. Putting into Operation	7
Preparing to operation.....	7
To adjust the water supply	8
XII. Interruption of water supply during working.....	8
XIII. To switch off	9
XIV. Cleaning	9
To clean the evaporator	10
To clean the cooling spiral	12
XV. Return of the apparatus for the Repair	12
XVI. Disassembly an reassembly of the glass part	13
XVII. Ordering dates for accessories	13
XVIII. Guarantee	13

Please read carefully before use!

I. Description of the apparatus

Distillation apparatus for producing of distilled water TYPE DP 4000 is identified for preparing of smaller amounts of distilled water.

By way of this apparatus it is possible to prepare approximately 4 litre of distilled water at one hour.

Apparatus is put together from two main parts - glass part and electrical part. Both parts are connected with plastic flange

In upper part of glass part is cooling coil. This upper part is partitioned off the lower part with glass partition. Boiling of tap water proceeds in the lower part of the glass part. Vapour comes through the tube which is connected to the centre of partition to upper part where is cooled and distilled water is drained of the distillation apparatus through the nozzle which is situated above glass partition..

II. Technical Data

Power consumption	W approx.	~ 3100
Rated current	A approx.	15
Electrical protection – tube fuse 5 x 20 F 8 A	A	1
Mains voltage	V/Hz	230/50
Distilled output:	l/h	~4
Conductivity of distillate: referred to 25 °C	µS/cm	1,5 – 2,5
Distilled temperature	°C	95
Cooling water consumption	l/h	~50
Dimensions of the apparatus	mm	190 x 190 x 600

III. General instructions and safety regulations

1. To avoid possible hazards pay good attention to the general instructions and safety regulations.
2. When you operate with this apparatus wear protective clothing, goggles and protective gloves.
3. Read and follow Operating manual carefully step by step.
4. Every user must be acquainted with this Operating manual and keep it within reach at all times.
5. The area in which the apparatus is to be used must conform to the appropriate electrical regulations. Connect the apparatus only to the earthen plugs and sockets.
6. Set up the apparatus on solid, flat surface only.
7. Use the apparatus in a dry environment only; do not use it in a potentially explosive atmosphere.

8. The available voltage and type of current must correspond to the data given on the type plate.
9. The electrical connection must have front end protection with fuse of at least 15 A.
10. Connections to the electrical mains and water supply must be made in such way as to avoid creating dripping hazards
11. Repairs within the base of apparatus (electric circuits, heating) must be made only by authorised electricians
12. Never use force.
13. Use original manufacturer's accessories and original manufacturer's spare parts only.
14. Use hoses delivered by the manufacturer only. Do not use old hoses.
15. Never send the apparatus to your supplier for repair without having cleaned it first.

Caution!

Do not operate the distillation apparatus unless it is properly connected to an earthen electrical installation which is in perfect condition. Make sure that earth connection complies with valid electrotechnic regulations. Otherwise, serious hazard of persons and fire endanger cannot be excluded.

IV. Connection to the Electrical Mains/Water Supply

Electrical mains:	230 Volts 50 Hz
Required front end protection:	min.15 A max. 16 A
Water supply:	minimal pressure 200 kPa maximal pressure 600 kPa
Fluctuation of pressure:	10 % of water pressure max. In case of a higher rate of fluctuations, we recommend using a commercially available pressure regulator.

V. Picture of the apparatus

Front view

Back view

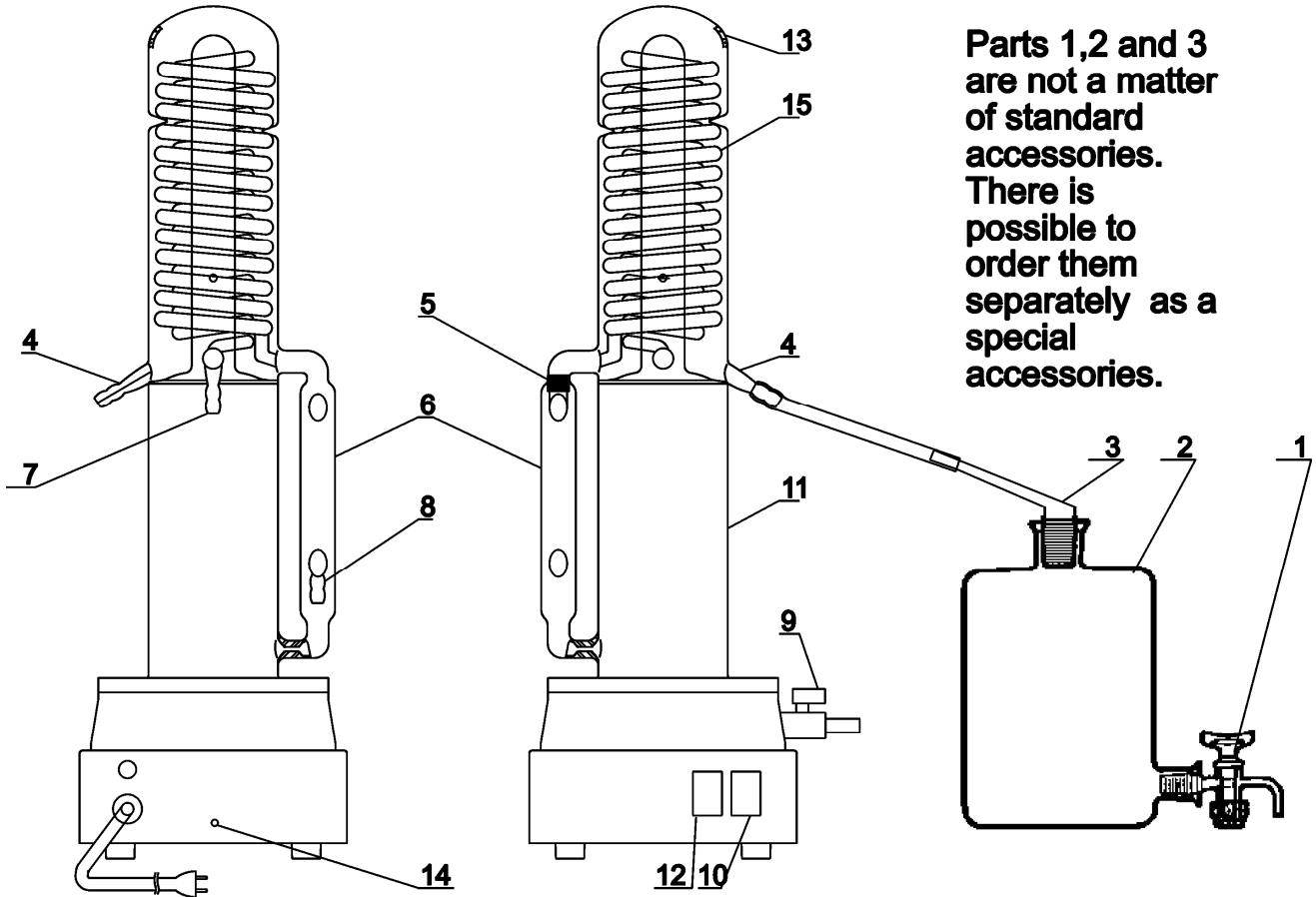

Parts 1,2 and 3 are not a matter of standard accessories. There is possible to order them separately as a special accessories.

Description of apparatus

1	glass stopcock of the reservoir bottle	9	outlet valve
2	reservoir bottle	10	mains switch
3	tubing connection	11	evaporator
4	distillate nozzle	12	green lamp mains
5	protective cap	13	degassing outlet
6	level tube	14	hole for switch off the temperature limiter
7	tubing connection for cooling water supply	15	cooling coil
8	overflow tubing connection		

VI. Unpacking the apparatus

- Open carton box
- Carefully remove upper part of interior cover made from polyurethane foam and lift up the apparatus from the box.
- Check the apparatus immediately for glass breakage and other damage which may have occurred during transportation.
- To each package of complete unit is attached Allen key with wrench widths 3 mm and hoses see below:

material	Outside diameter [mm]	Inside diameter [mm]	Wall thickness [mm]	Length [m]
PVC	19	14	2,5	3,5
Silicon	16	12	2	0,4

- When you want to bring apparatus to other place never hold it by side tube (6), hold only body of condenser and the base.

VII. Setting up the apparatus

- The apparatus set up always on a solid flat surface, have a respect to the fact that under the apparatus can temperature reach value 50°C
- The apparatus set in a dry environment.
- The lower edge of the apparatus must be level with, above edge of the sink.
- The minimum safety distance from the supply/water drain should be 1 m, to avoid the risk of splashing.
- Never set up the apparatus closer than this.

VIII. Installing of the Reservoir Bottle

In order to achieve conductivity of distillate water mentioned in „Technical data“ apparatus and the Reservoir Bottle must form closed system. Carbon dioxide from the air dissolves in water and would cause an increase in conductivity. A suitable reservoir bottle and bottle top are available as an original accessory (see XV.Ordering data for accessories)

- Fit glass stopcock (1) to the hole near the bottom of the reservoir bottle (2).
- Place reservoir bottle to the right of the apparatus.
- Outlet of the stopcock must be attainable for taking of distilled water.
- Fit the tubing connection (3) to the head of the bottle.
- Fit the supplied silicone tubing to the tubing connection (3)
- Connect free end of silicone tubing to the tubing connection of the distillate drain tube (4).

IX. Protective cap

Unscrew the protective cap (5) and place it for storage on the base of the unit behind the level tube (6).

X. Connecting of the Tubing

Use the PVC tubing supplied for the connections.

Note

Dip the end of the PVC tubing into hot water (approximately 80 °C) for about 3 minutes before use. This will make the tubing flexible so that it can easily fitted on the glass tubing connection.

Connecting of the cooling water supply

- Fit the end of the tubing supplied (outer diameter 19 mm) to the bent tubing connection (7) of the still body.
- Lead the tubing to the water tap and in a case of necessity cut it off to suitable length.
- Fit the second end of the tubing to the water tap.

Connecting of the water drainage

Water from the cooler (15) is led from the cooler to the tubing (6), which is also supplier of the water to the evaporator. Surplus water is led by the bent tubing connection (8) to the sink. The water level in the evaporator is given by position of the bent tubing connection (8) on the tubing (6).

- Fit the end of the PVC tubing (outer diameter 19 mm) supplied to overflow tubing connection (8)
- The second end lead to the sink and in a case of necessity cut it off to suitable length.
- Insert the second end to the sink and safe the tube against falling out off the sink
- Don't allow the tubing sag.

Attention: When you are fitting the end of PVC tubing on the overflow tubing connection (8) support the level tube (6) with your hand to avoid glass breakage.

To connect the outlet valve (9)

Fit one end of PVC tubing (outer diameter 14 mm) to the outlet valve (9) cut the second end off at suitable length and insert this end to the sink and safe it against falling out.

XI. Putting into Operation

Preparing to the operation

Make sure

- Make sure that main switch (10) is in the „off“ position (green lamp “mains” do not lighting).
- The screw cap (5) is unscrewed.

- Stopcock is closed
- The stopcock of the reservoir bottle and the outlet valve (9) are closed.

Plug the mains supply plug into the mains socket

To adjust the water supply

- Slowly turn on water tap to allow just a small amount of water to flow through the overflow (rate of water flow approximately 0, 5 to 1 l/min).
- As soon as water in the evaporator (11) almost covers the heating spiral: press the mains switch (10). The green lamp „Mains“(12) will light up.
- As soon as the water in the evaporator starts boiling, slowly reduce the water supply at the water tap until steam starts to escape from the degassing outlet (13) at the top of still body. Do not close water tap.
- Slowly increase the water supply until it is just sufficient to stop the steam from escaping
- The water supply is thus optimally adjusted

Note:

When operating the apparatus for the first time, let it run distilling in distilling mode for one hour. Discard the distillate.

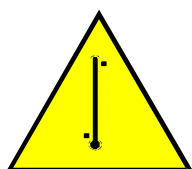

Attention

Do not touch the still body. Danger of burns.

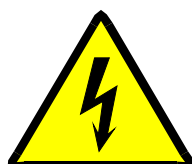

Attention

Risk of electric shock



Attention

Keep of accidental stroke of the hard material to glass part of distilling apparatus. There is hazard of breakage and in the case when it occurs in time of operating of the apparatus or shortly after it's switching of, there is risk of scalding too.

XII. Interruption of water supply

If there is insufficient supplying of water or if the water flow is interrupted, steam will start escaping from the degassing outlet (13). The water level in the evaporator will drop. After approximately 5 minutes the heater will be automatically switch off.

Caution

- Close the water tap.
- Switch off the apparatus (mains switch), and allow it to cool down for at least 15 minutes.
- Clear the defect in the water supply.
- Switch off the temperature limiter : take a piece of non-conducting material (length minimal 50 and maximal outside diameter 3 mm), insert it to the hole (14) on the back side of the base of the apparatus and slightly press on it . Remove used piece of non-conducting material from the hole (14).
- To continue distilling repeat the procedure starting at **XI. Putting into operation.**

XIII. To switch off

- Press the main switch. The green lamp will go out.
- Close the water tap.
- Pull out mains supply plug out of the mains socket.

Caution

The water still must have cooled down completely before the water can be drained through the outlet valve (9). Close outlet valve afterwards.

XIV. Cleaning

Deposits (e.g. lime) build up during the distillation process on the interior parts of evaporator (11). This gradually reduces the quality of the distillate.

When there are considerable deposits in the evaporator, or when the quality of the distillate no longer meets the requirements for the intended application, the evaporator must be cleaned.

When there are heavy deposits in the cooling spiral, they must be cleaned up latter; these deposits however do not affect the quality of the distillate.

Producer cannot accept any warranty claims if the heater is damaged as a result of overheating because the apparatus has not been sufficiently cleaned.

The following items are required for cleaning:

- protective clothing, gloves and goggles
- a suitable funnel
- a funnel stand, minimal length 70 cm
- a graduated jug of minimal capacity 2 liters
- a suitable vessel for the disposal of the acetic acid

- acetic acid, 10 - 50 %
- tap water for rinsing

Warning

Disconnect apparatus from the mains by pulling plug out of the socket before cleaning. There is risk of corrosive burns. Wear protecting clothing, gloves and goggles during cleaning. Dispose of the acetic acid in accordance with approved procedures. For your personal safety we recommend disconnecting the mains supply before cleaning. Keep the reservoir bottle (2) connected. Allow the water still to cool down completely. We are recommending mark the apparatus with table for instance: “Do not switch on! Cleaning with acid”.

To clean the evaporator

- Drain the water out of the evaporator through the outlet valve (9) after the apparatus has cooled down completely
- Close the valve again
- Hang tubing of the outlet valve (9) into the vessel for the disposal of the acetic acid. For safety reasons, place the vessel in a receiving tank.
- Screw the screw cap (5) tightly onto the pressure compensation opening of the level tube.
- Insert the funnel into the free end of the tubing leading from the overflow tubing (8). If necessary, dip the end of the tubing into hot water (approximately 80°C) for about 3 minutes before fitting. Check that funnel fits tightly.
- Support the funnel in the stand. The bottom of the funnel cone must be level with the distillate drain tube (4) (view picture on this page)
- Slowly pour in approximately 1 liter of acetic acid 10 - 50 %, using the graduated jug. Fill the funnel up to no more than one third of its capacity, to avoid spilling. Fill the evaporator up to no higher than the lower edge of the of the distillate drain tube (4). To regulate the filling rate: Place the funnel into a higher position to expedite the filling of the evaporator; return the funnel to a lower position to control the rate of addition of acid as it approaches the lower edge of the distillate drain tube, which point must not be exceeded.

Note

Take care that no acid drips into the reservoir bottle.

If acid drip into the reservoir bottle, carefully rinse the bottle and the bottle top.

- As soon as the deposits have dissolved drain the acetic acid out of the evaporator through the outlet valve (9) to the vessel.
- Close the outlet valve (9).
- Hang outlet valve tubing back into the sink.

To rinse the evaporator

- slowly pour approximately one liter of tap water into the funnel
- carefully fill the evaporator up to the lower edge of the distillate drain tube (4)
- drain it through the outlet valve (9) and close the outlet valve again
- repeat the rinsing three times
- remove the funnel, and hang the overflow tubing into the sink
- Unscrew the cap (5), and keep it on the base of the apparatus, behind the level tube

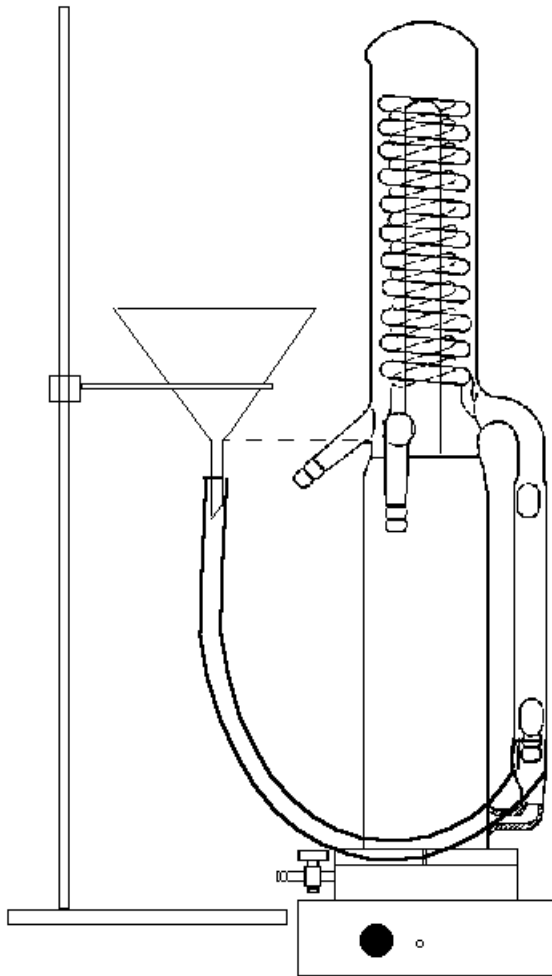

After cleaning

Let the apparatus run in distilling mode for one hour. Discard the distillate.

To clean the cooling spiral (15)

- After the apparatus has cooled down completely, drain the water out of the evaporator through the outlet valve (9). The outlet valve (9) must remain open.
- Hang the ends of the outlet valve (9) and the overflow tubing (8) into the vessel for disposal of the acid. For safety reasons, place the vessel in a receive tank
- Screw the screw cap (5) tightly onto the pressure compensation opening of the level tube (6).
- Disconnect the water supply tubing from the tap and insert the funnel into the free end of this tubing. Check that the funnel fits tightly.
- Support the funnel into the funnel stand (see fig. on this page). The bottom of the funnel cone must be level with the degassing outlet (13) (see fig. on this page)
- Slowly pour in approximately 300 ml of acetic acid, 10 - 50 %, using the graduated jug. Be carefully and avoid spilling.

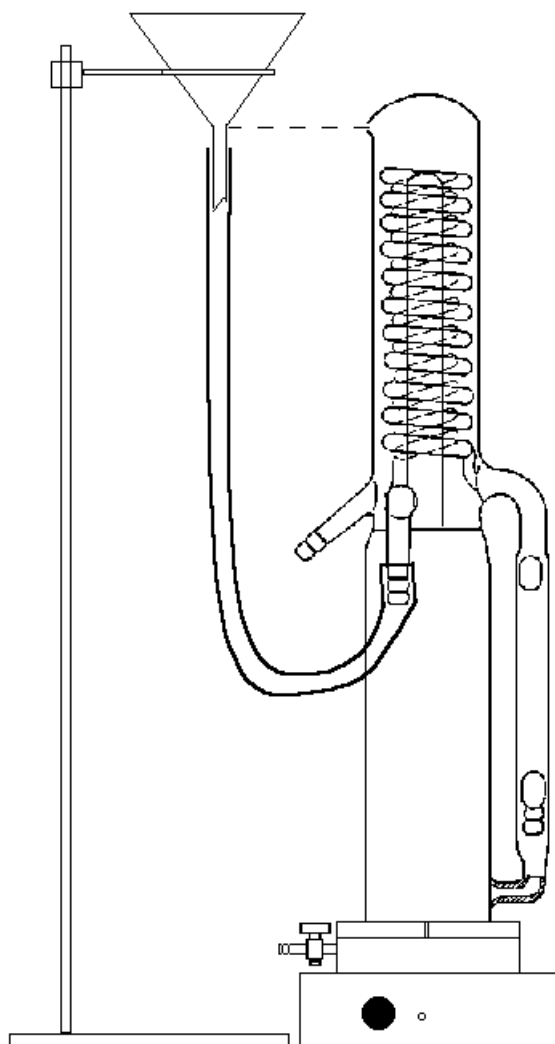

Caution!

Acetic acid flows out outlet valve and overflow tubing into the vessel.

- As soon as the deposits have dissolved pour 300 ml of tap water into the funnel
- After the liquid has flowed through hang the outlet valve and the overflow tubing back into the sink.

To rinse the cooling spiral

- Slowly pour approximately one litre of tap water into the funnel.
- As soon as the water has flowed through close outlet valve (9)
- Remove the funnel, and reconnect the water supply tubing to the water tap.
- Unscrew the screw cap (5), and keep it on the base of the apparatus, behind the level tube (6).

After cleaning

Let the apparatus run in distilling mode for one hour. Discard the distillate.

XV. Return of the apparatus for the Repair

Carefully clean the instrument, and send it to your supplier. Please describe your complaint in detail.

XVI. Disassembly and reassembly of the glass part

Disassembly

Drain all water from the apparatus. To carefully loosen all eight screws of the halving clamping ring. Use supplied Allen key. Screws loosen gradually, so that the pressure in both of the two halves of the ring is as far as possible uniform. Otherwise it may lead to breaking of the glass flange due to uneven pressure.

Loosen the screws completely. One hand grip the glass part of the distillation apparatus and remove the halves of clamping ring. From the flange of the glass stills slip of silicone o-ring

Reassembly

Insert a silicone o-ring to the grooves of the base. Slip the second silicone o-ring over the flange of the glass part of the still. Place flange of the glass part of the still to the centre of the base. The flange must completely fit into the recess in the base. Put on the both halves of the clamping ring. The holes of the halves of clamping ring must be exactly above the holes in the base and second silicone o-ring must fit into the groove in the halves of clamping ring. Insert screws to the holes of the clamping ring and gradually tighten the screws with using of Allen key. Never fully tighten one half of the clamping ring and subsequently the second half. This could lead into an uneven distribution of pressure on the flange of the glass part of the apparatus and cause of breakage. Tighten screws until the distance between the lower edge of the clamping ring and upper edge of the base is approximately one millimetre alongside entire circumference.

XVII. Ordering dates for accessories

- a) tubing
- b) reservoir bottle (2 l)
- c) tubing connection with NS 29/32 for connection of distillate drain tube and reservoir bottle
- d) stand for funnel
- e) funnel (diameter 75 mm)

XVIII. Guarantee

Producer gives 12 month guarantee for this apparatus. V guarantee expires if it would be evidenced, that attendant did not follow operating manual. Guarantee does not be applied in case of mechanical damage of apparatus as well.