

**TERMOCICLADOR GET-S
THERMAL CYCLER GET-S
THERMOCYCLEUR GET-S**

REF. - CODE - RÉF. - ZFD019



Este manual es parte inseparable del aparato por lo que debe estar disponible a todos los usuarios del equipo. Le recomendamos leer atentamente el presente manual y seguir rigurosamente los procedimientos de uso para obtener las máximas prestaciones y una mayor duración del mismo.

This manual should be available for all users of these equipments. To get the best results and a higher duration of this equipment it is advisable to read carefully this manual and follow the processes of use.

Ce manuel est une partie indissociable de l'appareil et doit être mis à la disposition de tous les utilisateurs de l'équipement. Nous vous recommandons de lire attentivement ce manuel et de suivre scrupuleusement les procédures d'utilisation afin d'obtenir des performances maximales et une plus longue durée de vie de l'appareil.

LANGUAGE INDEX

Spanish 1-30
 English 31-59
 French 60-88

TABLE OF CONTENTS

1 Safety Guidelines33
 2 Installation33
 2.1 Package Contents Verification33
 2.2 Normal Operating Conditions34
 2.3 Transportation and Storage Requirements.....34
 2.4 Power Requirements34
 3 Instrument Characteristics.....34
 3.1 Instrument Construction34
 3.2 Specialty.....37
 3.3 Specifications.....39
 4 Operation instruction40
 4.1 Power on40
 4.2 Menu structure41
 4.3 File instructions42
 4.3.1 Create or edit file42
 4.3.2 Delete file47
 4.3.3 Copy file47
 4.3.4 Rename file47
 4.3.5 Run file47

4.4 Setting.....	49
4.4.1 Run Setting.....	50
4.4.2 System Setting	50
4.4.3 E-mail Setting	51
4.4.4 GLP Report	51
4.4.5 Device information	52
4.5.6 Software update	52
4.5 Tools.....	52
4.5.1 Gradient calculator.....	53
4.5.2 Tm Calculator.....	53
4.7 Log In.....	55
4.7.1 New User	55
4.7.2 Change Password and Delete User.....	56
5 Maintenance and Troubleshooting	56
5.1 Machine Maintenance	56
5.2 Troubleshooting	56
5.3 Notes	57
5.4 Error messages and correspond solutions.....	58
5.5 Cause of the unnormal phenomenon and correspond solution	59
6 After-sales Service.....	59

1 SAFETY GUIDELINES

1. Instrument Safety Warning Labels



High temperature warning: To avoid burning, please don't touch directly all areas labeled with safety warning and the hot areas described in manual.



Electric shocks Warning: To avoid electric shock accidents, please operate strictly according to the request of electric Shocks warning.



Note: Please note that reminder contains important information and be sure to read them carefully. Otherwise, it will cause the instrument to not work properly or even damage the instrument.

2. Safe Use

Please read the following information before using the instrument and be sure to comply with the following basic security measures. Failure to follow the measures or the other warnings in the manual will affect the normal work of the instrument, even damage the equipment and hurt people.

- Prohibit using the instrument in humid, dusty, high temperature, magnetic environment.
- Prohibit opening the cover of instrument or touching the inner device of instrument.
- Prohibit blocking the air flow vents and be aware of gloves or rags sucked into air flow vent in the bottom of instrument.
- Please keep instrument clean and maintain it regularly.

Note: Please disconnect the power immediately and contact the supplier or consult certified mechanic for assistance when any of the following occurs:

- Instrument be moistened by rain or water, or any other liquid.
- Instrument can't work properly, especially any abnormal sound or odor appears.
- Instrument's function changes obviously.

2 INSTALLATION

2.1 Package Contents Verification

Please open the box and check the following list when you receive the GET-S Thermal Cycler.

Name	Quantity
Thermal Cycler	1
Power Line (single-phase 3-wire)	1
Spare fuse (8A , 250V)	2
User Manual	1

In the event of discrepancy, please keep the original box and contact with your distributor immediately.

2.2 Normal Operating Conditions

- Used indoors
- Temperature 10 °C-30 °C
- Relative Humidity 10%—85%
- Please keep it stay away from heat sources.
- Do not block the air flow vent in the side and bottom of the instrument, do not put any other articles around the instrument within 30cm, and keep the air flow vents of the instrument smoothly.

2.3 Transportation and Storage Requirements

- Ambient temperature: -20 °C- +55 °C
- Relative humidity \leq 90%

2.4 Power Requirements

The instrument has switching power supply with PFC function. The range of writable voltage is wide, it can run normally during voltage AC 100-240V and frequency 50/60Hz, 3 single wires for power cord, and it must be fitted with a reliable grounding.

Warning: To avoid electric shock accident, instrument must be fitted with a reliable grounding.

3 INSTRUMENT CHARACTERISTICS

3.1 Instrument Construction

A. Host machine

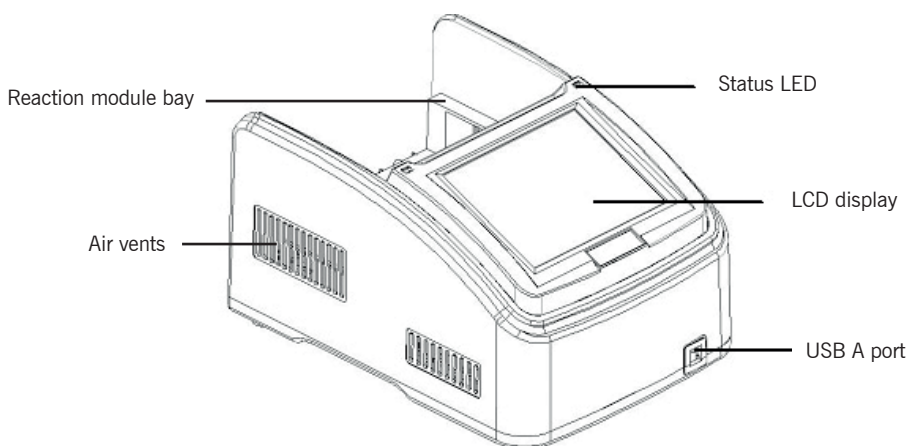

Figure 1. Frontal view of the thermal cycler

- Reaction module bay — holds inserted reaction module
- Air vents — allows the thermal cycler to cool quickly
- Status LED — indicates status of reaction module
- LCD display — displays operating status
- USB A port — connects to a USB key, computer mouse, or other USB devices

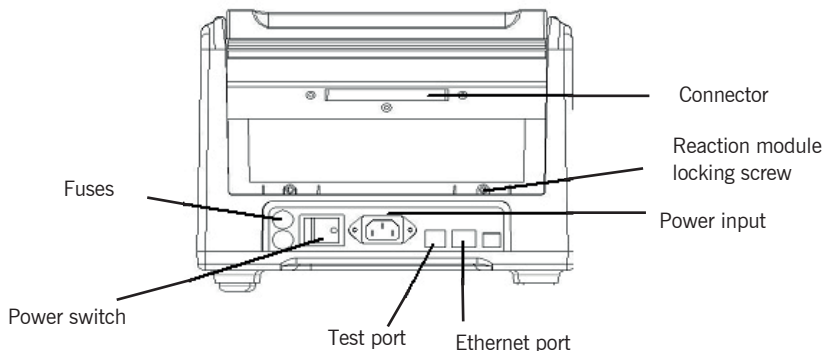

Figure 2. Back view of the thermal cycler

- Connector — connection between host machine and reaction module
- Reaction module locking screw — locks reaction module
- Test port — for service testing only
- Ethernet port — connects the thermal cycler to a computer

B. Reaction module

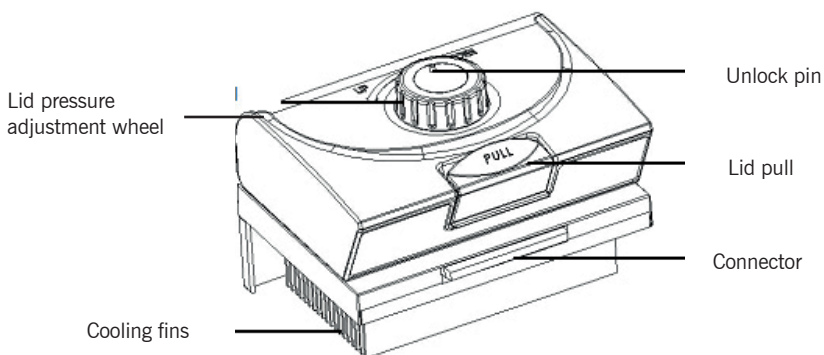

Figure 3. The lid and cooling fins of a 96-well reaction module

- Lid pressure adjustment wheel — adjust the lid pressure
- Unlock pin — to unlock wheel
- Lid pull — opens and closes the lid
- Connector — connection between host machine and reaction module

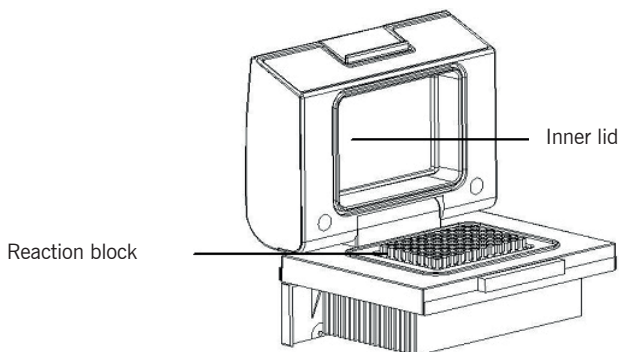

Figure 4. View of an open 96-well reaction module

- Inner lid — maintains the lid temperature to prevent condensation and evaporation
- Reaction block — holds reaction vessels, including tubes and microplates

C. High Performance Smart Lid

To achieve optimum pressure on the tubes the GET-S Thermal Cycler is equipped with a height adjustable heated lid.

Lid closing:

After the samples have been placed in the block close the lid. Turn the wheel clockwise until you hear a clicking noise. In this mode the pressure will not increase further, even when you keep on turning the wheel.

Note: The pressure of the lid has been optimized for a fully loaded block. If only very few tubes are loaded to the block you should place dummy tubes in the four corner positions to avoid damage of tubes by excessive pressure.

Lid opening:

First: Release pressure by turning the wheel counterclockwise. As soon as there is no more resistance the pressure has been released.

Then: Open the lid with by pushing the front button.

Important: The lid should not be opened under pressure because this leads to damage of the locking mechanism.

D. Releasing blocked lid wheel

Note: When the lid is in the very up or down position, it may happen that the wheel is uncoupled. In this situation the clutch mechanism is active in both directions (clicking noise in either direction).

To unlock wheel, press down metal pin with a ball pen and turn wheel carefully. This pin overrides the automatic clutch mechanism. Thus, care must be taken not to apply excessive pressure.

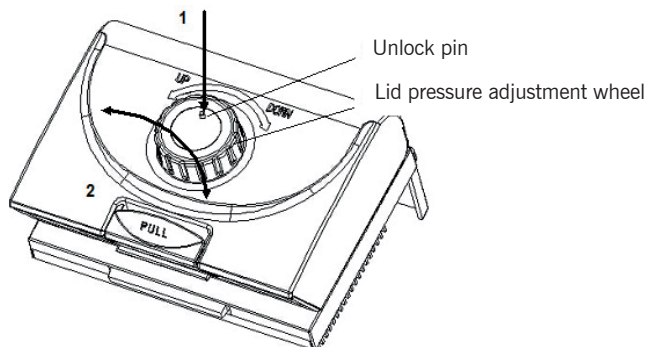

Release lid in upper position:

- 1) Press pin
- 2) Carefully turn wheel while holding the pin down **CLOCKWISE**, until you feel normal resistance (no more clicking noise, clutch is released). Release pin and turn lid down, until the clutch mechanism is activated (clicking noise, optimum pressure applied).

Release lid in down position:

- 1) Press pin
- 2) Carefully turn wheel while holding the pin down **COUNTERCLOCKWISE**, until you feel normal resistance (no more clicking noise, clutch is released). Release pin and turn wheel counterclockwise until pressure is completely released. Open the lid.
Important: When the clutch mechanism is active (= optimum pressure is applied), do not use pin to further increase lid pressure. This would lead to damage of tubes and instrument!

3.2 Specialty

1. Each thermal block has 3 independent temperature control sensors and 6 Peltier heating units to ensure accurate and uniform temperature across block surface and provide users for replicating previous condition set-up.
2. Reinforced aluminum module with anodizing technology can keep rapid heating-conducting property and have enough corrosion resistance.
3. High heating and cooling rate, max. Ramping rate 4.5 °C/s, can save your precious time.
4. Stepless adjustable hot lid with pressure-protection, fit tubes of different heights to avoid tube melt and evaporation.

5. Android interface, 8" (800×600, 16 colors) TFT color touchscreen with graphical display provides easy use for setting up and monitoring.
6. Built-in 11 standard program file template, can quickly edit the required files.
7. Folder management, user can build directory.
8. The running program and left time can be displayed in real time, allow to edit file when program is running.
9. One-click quick incubation function can meet experiment's needs such as denaturation, enzyme cutting/enzyme-link and ELISA.
10. Internal flash memory for 10000 typical PCR files in free configurable folders.
11. Hot lid temperature and hot lid work mode can be set to meet different experiment's need.
12. Automatic restart after power failure. When power is restored, it can continue to run unfinished program.
13. GLP report records every step to provide accurate data support for experiment result analysis.
14. User Login Management, three-tier permission, password protection function to ensure data security.
15. Compatible with devices such as mouse and keyboard and capable to transfer data and perform software updates via USB Drive.
16. Support USB and LAN to update software.
17. One computer can control many sets of PCR via network connection.
18. Support email-alert function when experiment is over.

3.3 Specifications

Model	GET-S
Code	ZFD019
Capacity	96×0.2 mL
Temperature Range	0-105 °C
Max. Heating Rate	4.5 °C/s
Max. Cooling Rate	4 °C/s
Uniformity	≤±0.2 °C
Accuracy	≤±0.1 °C
Display Resolution	0.1 °C
Temperature Control	Block \ Tube
Ramping Rate Adjustable	0.1-4.5 °C
Gradient Temp. Range	30-105 °C
Gradient Spread	1-30 °C
Hot Lid Temperature	30-110 °C
Hot Lid Height Adjustable	Stepless Adjustable
Number of Programs	10000+ (USB FLASH)
Max. No. of Step	30
Max. No. of Cycle	200
Time Increment/Decrement	1 sec - 600 sec
Temp. Increment/Decrement	0.1-10.0 °C
Pause Function	Yes
Auto Data Protection	Yes
Hold at 4 °C	Forever
LAN to computer	Yes
LCD screen	8-inch, 800×600 Pixels, TFT
Communication	USB2.0, LAN, WiFi
Dimensions	390mm×270mm×255mm (L×W×H)
Weight	9kg
Power Supply	100-240VAC, 50/60Hz, 600W

4 OPERATION INSTRUCTION

4.1 Power on

Connect power cord to the back of instrument then plug into power source and switch to “-”. When the instrument is on, the buzzer should be heard, and the LCD screen lights up to show the **Boot** screen (Figure 5). After that, the operating system starts up and then goes to the **Self-Test** screen (Figure 6). During this phase, the LCD screen displays the product name, company LOGO and its name. When it's over, the system performs the **Home** screen (Figure 7) as shown below.

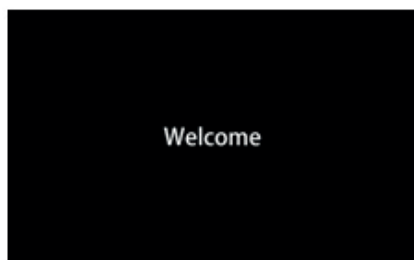

Figure 5. The boot screen

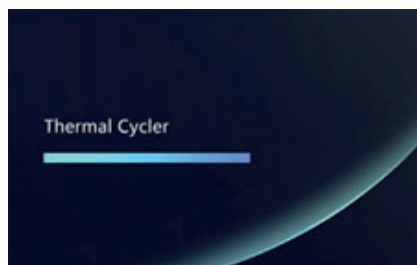

Figure 6. The self-test screen

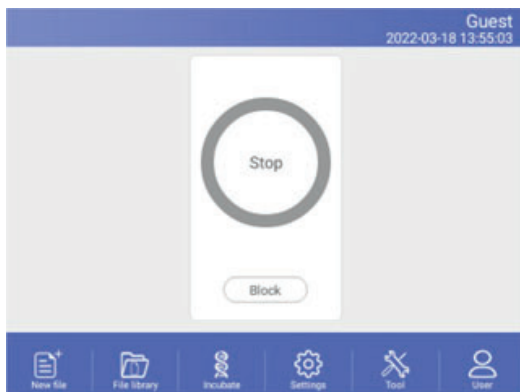
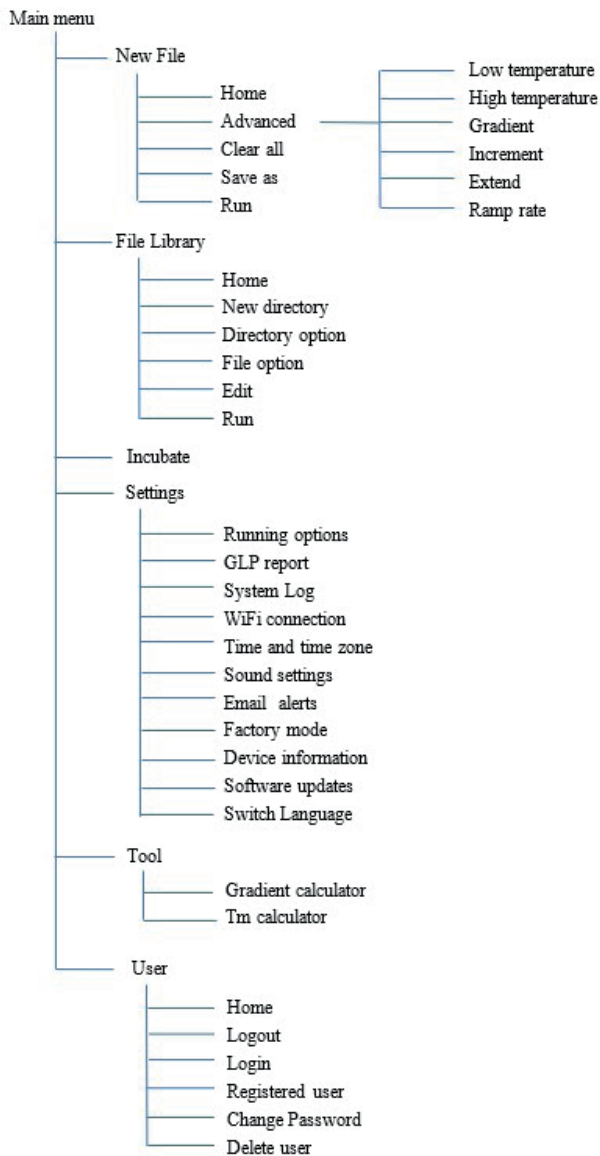

Figure 7. The home screen

4.2 Menu structure



4.3 File instructions

File is composed by **Temperature Step** and **Cycle Step**. Each **File** can hold up to 30 **Steps**. **Temperature Step** contains **Temperature, Time, Gradient, Ramp Rate, Temperature Increment and Time Extend**. The maximum number of **Cycles** is 200 times.

4.3.1 Create or edit file

In the **Home** screen (Figure 7), touch **File** button to enter **File Library** screen (Figure 8).

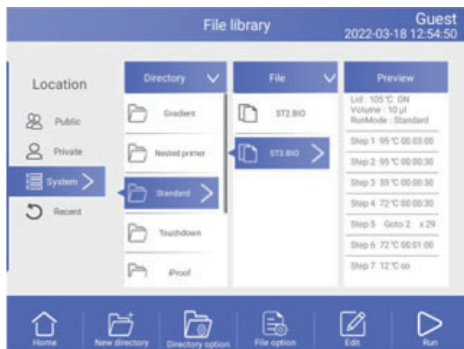

Figure 8. File Library

1). Change Target Temperature and Hold Time

■ From a new file

Touch **New File** button in the **File Library** screen (Fig. 8) to create a new file (Fig. 9).



Figure 9. Create a new file

- In the **New File** screen, touch **+Temp** button to add a **Temperature Step**, touch **+Cycle** button to add **Cycle Step (GOTO step)**, use the pop-up numeric keypad to enter a new value for the target temperature or hold time.
- From an existing file

Select a file in the **File Library** screen (Fig. 8), touch **Edit** button to modify selected files.



Figure 10. Edit an old file

In the **Edit File** screen (Fig. 10), select a desired step by touching anywhere in the step. Change a time or temperature by touching the desired field and entering a value using the pop-up numeric keypad. To enter an infinite hold, fill time field with 00:00.

2). Run mode

There are two run modes: standard mode and fast mode. Users can choose the mode according to their actual needs. The fast mode takes less experimental time than the standard mode.

3). Edit Step

Select a desired step, touch **Options** button to enter **Step Options** screen (Figure 11). Parameters can be edited by selecting among **Gradient**, **Ramp Rate**, **Temperature Increment** or **Time Extend**. Table 1 lists the parameters for temperature and gradient steps with the limits of those parameters.

After entering **Gradient** values, the gradient distribution table (Figure 11) will be shown at bottom of the screen. Touch **OK** to save changes and return **Edit File** screen (Figure 12).

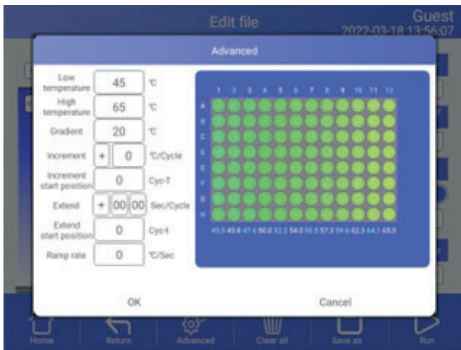

Figure 11. Set the Gradient



Figure 12. Gradient on Step 3

Table 1. List of parameters for temperature and gradient steps

Parameter	Ranges	Description
Temperature	Temperature in °C: The target temperature between 0.0 and 105.0 °C in tenths of a degree	Instructs the thermal cyler to ramp to the target temperature.
	Hold time: The hold time between 1 sec and 120 min in the format of min: sec. To enter an infinite hold, touch 0 button, the symbol ∞ (infinite) will come out.	
Gradient range	Lower: The lower temperature in the gradient. Enter a number between 30.0 and 105.0 °C in tenths of a degree. Upper: The upper temperature in the gradient. The max. temperature is 105.0°C. Enter a temperature within 30.0 °C of the lower temperature.	Instructs the thermal cyler to ramp to the target temperature gradient across the block and hold that temperature gradient for the specified amount of time.
	Hold time: The hold time between 1 sec and 120 min in the format of min: sec. To enter an infinite hold, touch 0 button, the symbol ∞ (infinite) will come out.	
Increment	A temperature from -10.0 °C to 10.0 °C per cycle in tenths of a degree.	Applies only to a temperature step. Instructs the thermal cyler to increment (change) the target temperature of a step with each cycle, where a positive number increases the temperature, and a negative number decreases the temperature.
Ramp rate	A number from 0.1 to 4.5 °C per sec	Applies only to a temperature step. Instructs the thermal cyler to ramp to the target temperature at the specified ramp rate in that step.
Time	A time from 1 sec to 120 min	Instructs the thermal cyler to hold the temperature for the specified amount of time.
Extend	A time from -600 sec to 600 sec per cycle.	Applies to both temperature and gradient steps. Instructs the thermal cyler to extend the hold time with each cycle. A positive number increases the hold time and a negative number decreases the hold time.

3). Insert a Step

Insert a step if a new temperature, Cycle (GOTO), or gradient step is needed. Follow these instructions to insert a step to the right of a preexisting step.

- I. Touch a step to the left where the new step will be inserted.
- II. Touch the **+Temp** button to insert a step or the **+Cycle** button to insert a Cycle (GOTO)
- III. Touch the time or temperature field to edit the parameter in the new step or touch the step or times field to edit the parameter in the new Cycle (GOTO).

4). Delete a Step

To permanently remove a step from file.

- I. Select the step to be deleted.
- II. Touch **Delete** button to delete the selected step.

5). Remove or add a temperature gradient

Select a step in **Edit file** screen and touch the **Options** button to enter **Step Options** screen. Touch **Cancel** button to remove a temperature gradient or fill the Step Options and touch **OK** button to add a temperature gradient.

6). Save file

When editing is completed, touch **Done** to enter **Save File** screen (Figure 13) and touch Browse button to set file saving path. Then touch **File Name** button to name file and finally touch **Save** button to save file and return **File Library** screen (Figure 14).

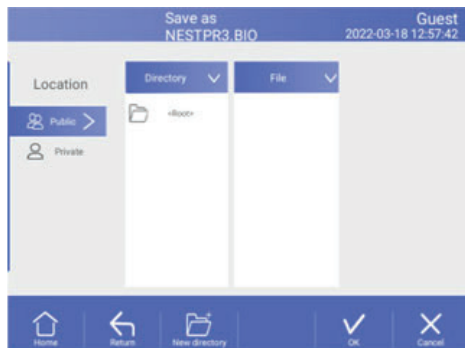

Figure 13. Name the file and select the path

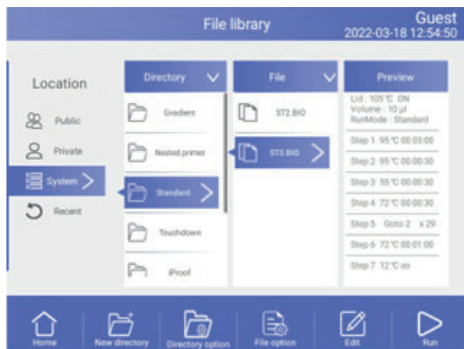

Figure 14. New file in the library.

4.3.2 Delete file

In the **File Library** screen (Figure 8), touch **Options** button to select the file to delete, and the query dialog window will pop up when touching **Delete** button and delete this file by touching **Yes** (Figure 15). Only one delete per time is allowed to prevent any files being mistakenly deleted.

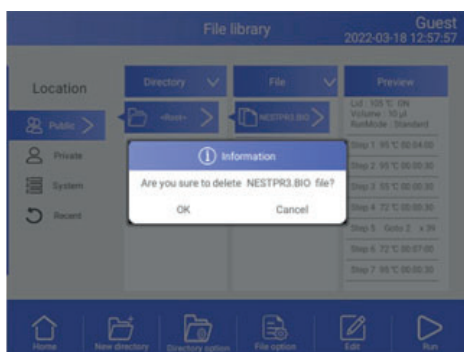

Figure 15. Delete a file.

4.3.3 Copy file

In the **File Library** screen (Figure 8), touch **Options** button to select the file to copy and touch **Copy** button. Then enter the save path and touch **Paste** button to finish copy.

4.3.4 Rename file

In the **File Library** screen (Figure 8), touch **Options** button and select the file to rename. Then touch **Rename** button and enter new file name in the dialog window to rename files

4.3.5 Run file

In the **File Library** screen (Figure 8), select the file needed and touch Run button to enter the **Run File Setup** screen (Figure 16).

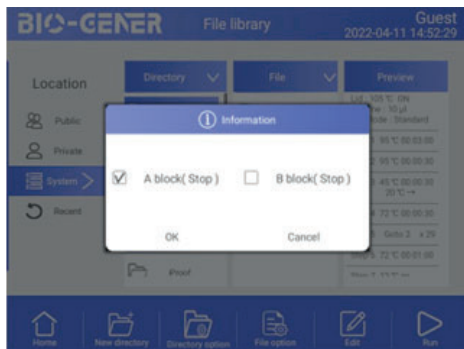

Figure 16. Run file setup

In the **Run File Setup** screen (Figure 16), select the Block which needs to run, enter the volume (**not necessary to be in block temperature control mode**). Touch **Start** button and enter the File Running screen (Figure 17).

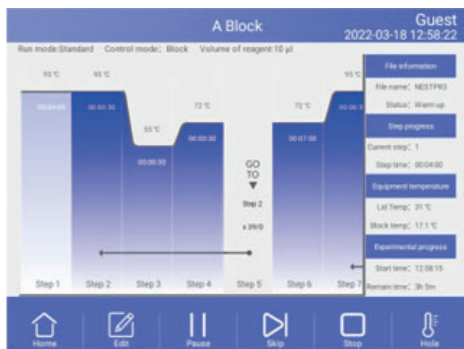

Figure 17. File running.

1). Parameter

- Start Time — system time when file starts to run.
- Remain Time — remaining time for the experiment.
- Lid Temp — current hot lid temperature.
- Step — current step.
- Step Time — current step time.
- Block Temp — current block temperature.

2). Pause

Touch **Pause** button to pause running file and touch **Resume** button to restore running.

3). Stop

Touch **Stop** button to stop a running file.

4). Skip

Touch **Skip** button to jump to next step.

5). Go to another screen

Touch **Home** button to back the **Home** screen, or touch Circle in the middle of the screen (Fig. 18) to enter the running file screen (Fig. 17).

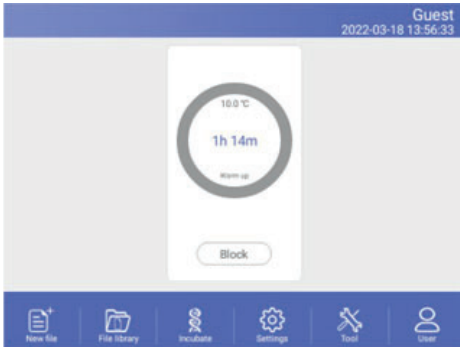

Figure 18. The file is running of home screen.

4.4 Setting

In the **Home** screen, touch **Setting** button to enter the setting screen (Figure 19).

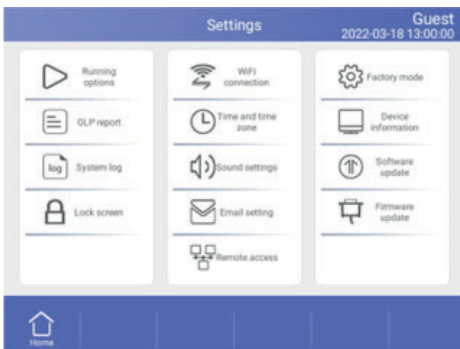

Figure 19. Setting menu

4.4.1 Run Setting

In the **Setting screen** (Figure 19), select **Running Options** to enter the following screen (Figure 20).

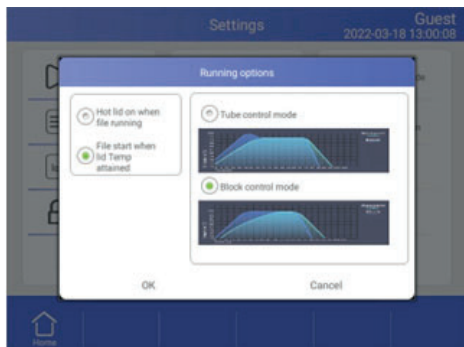

Figure 20. Run parameter setting

1). Hot lid work mode setting

In total there are 2 working modes and default mode is the hot lid will be on when file running.

2). Temperature control mode

The temperature control mode contains block control mode and tube control mode. The block control mode is suitable for performing normal PCR and the tube control mode is for experiments that require higher environment conditions. The system default is block control mode.

4.4.2 System Setting

In the Setting screen (Fig.19), can set time and date, sound, WiFi connection.

1). Time and date

Set the system time and date.

2). Sound

- Keyboard sound — sound when touch button.
- Alarm sound — sound when system error occurs.
- File end sound — sound when file running is complete.
- Temp to reach sound — sound when the target temperature reaches.

3).WiFi connection

If you need to open WiFi function, touch WiFi button.

4.4.3 E-mail Setting

In the **Setting** screen (Fig. 19), select **E-mail alerts** to enter the E-mail Setting screen (Fig.21).



Figure 21. E-mail setting

1). Status of email alert

After program is over it will automatically send email if chose Enable.

2). Test email

Test email function is to test whether email can send or not.

3). Save

Touch OK to save information and email setting record.

4.4.4 GLP Report

Record of every file name, time of start run this file, block number, source files path (Figure 22).

GLP Report — Record the time and temperature for each step.

Number	Finish time	File	Block	User
196	2022-03-18 12:58:54	ST3	C	Guest
195	2022-03-18 12:58:51	ST3	B	Guest
194	2022-03-18 12:58:49	ST3	A	Guest
193	2022-03-18 12:58:09	NESTPRO	C	Guest
192	2022-03-18 12:58:06	NESTPRO	B	Guest

Figure 22. GLP report

4.4.5 Device information

Show the machine name, the SN, the control version and UI version (Figure 23).



Figure 23. Local information

4.5.6 Software update

Copy the new software to the root directory; insert the USB flash disk into the USB port, then touch “Software update”, return to Android desktop when updating, and immediately reopen the updated App.

4.5 Tools

In the **Home** screen, touch **Tool** button to enter the Tool screen (Figure 24).

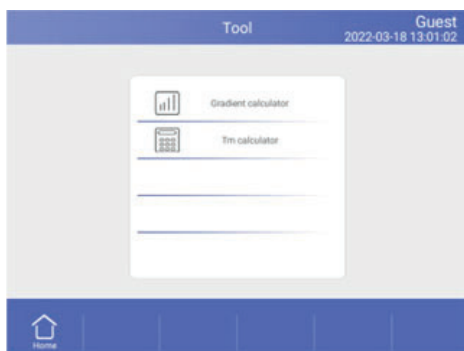

Figure 24. Tool menu

4.5.1 Gradient calculator

The temperature value for each column is shown after entering the block target temperature and gradient range (Fig. 25).

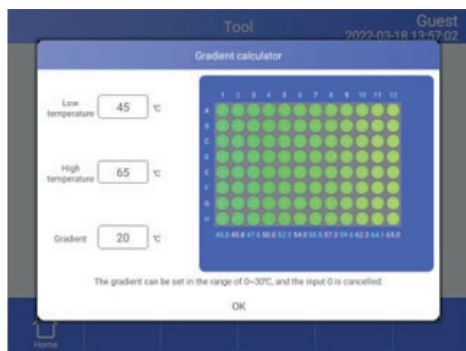

Figure 25. Gradient calculator

4.5.2 Tm Calculator

Touch the fields to enter concentrations and the primer sequences, then touch Calculate Tm (Fig. 26) to calculate the melting temperatures. Maximum input for each primer sequence is 30.



Figure 26. Tm Calculator

4.6 Incubate

In the **Home** screen, touch **Incubate** button to enter the **Incubate wizard** screen (Fig. 27).



Figure 27. Incubate wizard

In the **Incubate wizard** screen (Fig. 27), select the desired block and enter the block temperature and the hold time. Then touch **Start** button to enter Incubate **Running screen** (Fig. 28).

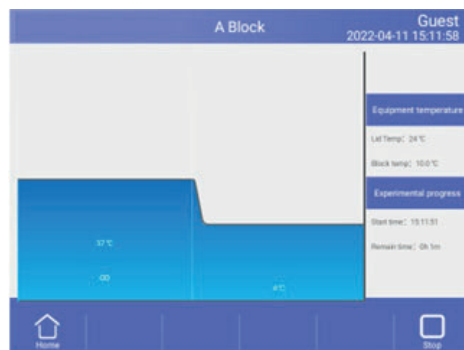

Figure 28. Incubate running.

4.7 Log In

In the **Home** screen, touch **User** button to enter the **User** screen (Fig. 29).

NOTE: Administrator user's initial password is "123456", you can change the password after logged in.

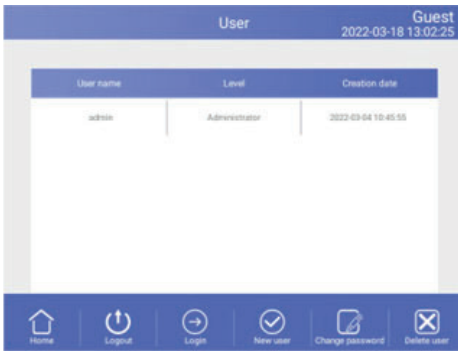

Figure 29. User management

4.7.1 New User

In the **User** screen (Fig. 29), touch **New user** button to enter the **New User** screen (Fig. 30). Enter user name and password, then touch **OK** button to enter the **User** screen. In the User screen, select the registered user who needs to log in and press the "Login" button.



Figure 30. New user

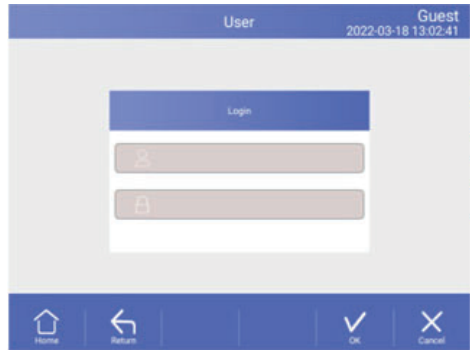

Figure 31. Login

4.7.2 Change Password and Delete User

Only after login can passwords be changed and users be deleted; can other users be deleted from the login administrator account.

5 MAINTENANCE AND TROUBLESHOOTING

5.1 Machine Maintenance

1). Regular cleaning

A. Clean the holes on reaction block with neutral soap solution (Do not use any solvent containing strong alkali, strong alcohol and organic solution)

B. Spaces near the left, right air vents and under the machine should be always kept free. It is very important to clean the dust around air vents regularly.

C. Clean the reaction block regularly and remove any residue inside cavities to prevent any affects to the temperature control (we suggest using soft cloth).

2). Replace fuse

The machine has two fuses. Replace them according to the following once damage occurs.

A. Turn off the machine and unplug power source.

B. Unscrew the fuse box with flat screwdriver and replace the damaged fuses with new 8A 250V fuses. After replacement, screw back in the fuses box.

Note: Please contact your distributor for repair when encountering any problem replacing fuses.

5.2 Troubleshooting

1). Dissatisfactory Results

Biological, programmatic and hardware problems may contribute to any unsatisfied results of experiment. In order to distinguish the hardware problems from other possible problems, the machine is equipped with built-in self-test hardware and self-diagnosis software. Below is the detailed description. According to the experiences, most problems are related to biological and programmatic factors.

FAQ as follows:

- A. Incorrect or insufficient reactants.
- B. Denaturation temperature is too high or too low. It is suggested to set the temp. within range of 90-95 °C for 40 seconds. The duration can be adjusted in accordance with reaction volume.
- C. Annealing temperature is too high or too low; It should be between 55-70 ° C and 20 to 30 chains
- D. Reactant concentration is too high or too low.
- E. Preparation process without special treatment.
- F. Time and temperature value in progress are not appropriate.
- G. The temperature of sample is slightly too low while the temperature of block is slightly too high.
- H. Check whether the PCR tubes are well placed. Smearing little mineral oil on the surface of holes will increase the thermal conductivity.

2). Machine's self-test and self-diagnosis function

The machine will run the self-test program when booting. The software and hardware of machine will show the results so as to inform users the potential problems, minimize the failure of experiment and display the error message when problem occurs.

5.3 Notes

1). Power

- A. No special requirement for the power supply. Any AC power source within range of 85V~264V is applicable. However, to prevent from causing any damage to the machine, it is better to apply low voltage fluctuation power sources, otherwise please consider installing power supply regulator.
- B. It's prohibited to cut off the power to terminate a running experiment. It's very harmful to the machine.

2). LCD screen

Avoid using UV disinfection to clean the machine to prevent any damage. Avoid any bump or scratch to the LCD screen while using.

3). Note about cleaning

Avoid any liquid getting inside the machine while cleaning the base of machine. Due to the possible usage of radioactive substance during experiment, please carefully handle cleaning. It is not suitable to use the machine in moisture or hot environment.

Note: Please do read the notes carefully! you may damage the machine if don't operate according to the above requirements.

5.4 Error messages and correspond solutions

No.	Error message	Cause and correspond solution
1	File name can not be empty	File name does not support null character
2	If have same file name, please re-name	Don't support multiple files with the same name's file
3	Module sensor 1, short circuit	Hardware problem, need to repair
4	Module sensor 1, open circuit	Hardware problem, need to repair
5	Module sensor 2, short circuit	Hardware problem, need to repair
6	Module sensor 2, open circuit	Hardware problem, need to repair
7	Module sensor 3, short circuit	Hardware problem, need to repair
8	Module sensor 3, open circuit	Hardware problem, need to repair
9	Module sensor 4, short circuit	Hardware problem, need to repair
10	Module sensor 4, open circuit	Hardware problem, need to repair
11	Radiator sensor short circuit	Hardware problem, need to repair
12	Radiator sensor open circuit	Hardware problem, need to repair
13	Lid sensor short circuit	Hardware problem, need to repair
14	Lid sensor open circuit	Hardware problem, need to repair
15	Power output short circuit	Hardware problem, need to repair
16	Module temperature too high	Air flow vent is blocked or circuit problem, need to repair if latter
17	Module temperature too low	Temperature of environment is too low or circuit problem, need to repair if latter
18	Radiator temperature too high	Air flow vent is blocked or fan problem, need to repair if latter
19	Radiator temperature too low	Temperature of environment is too low or circuit problem, need to repair if latter
20	Lid temperature too high	Circuit problem, need to repair

5.5 Cause of the unnormal phenomenon and correspond solution

No.	Description of problem	Cause and correspond solution
1	No display after opening the machine	Check whether plug inserted correctly and power output has electricity, pull out the plug while turning off, and check the fuse
2	Turn on, the machine start running according to the program	The power was off before ending the last program
3	The fan run fast some time, slow sometimes	Normal. Fan is used dissipating heat while pump is working, not for reaching the sited temp.
4	Have slight pat or squeaking sound while machine is working	Normal. When is needed large power for intense or cold, the switch power supply is adjusted automatically causing the sound of pat or Squeaking.
5	Increasing or decreasing module temperature too slow	Check whether the setting of rate of variable temperature and fan is normal or not
6	Wrong display appears in the screen	Caused by electrostatic pulse or power surge. please turn off and open, does not affect program running

Note: If the above problems can't be solved, please contact your distributor in time.

6 AFTER-SALES SERVICE

1. This product is warranted under normal usage for two years from the date of purchase.
2. The warranty does not cover the following circumstances:
 - 1). Damage caused by natural disasters factors (such as fire, earthquake, flood, wind disaster, thunderbolt etc.) and failure conditions caused by abnormal voltage, public nuisance and chemical substances.
 - 2). Failure or damage caused by use this product under abominable conditions (such as oil fume, dust, damp and direct sunlight etc.) or inappropriate use according to the instruction book.
 - 3). Damage caused by drop, move, transport, entry of foreign matter and other factors unrelated to manufacture process.
3. Contact your distributor for warranty claims.