

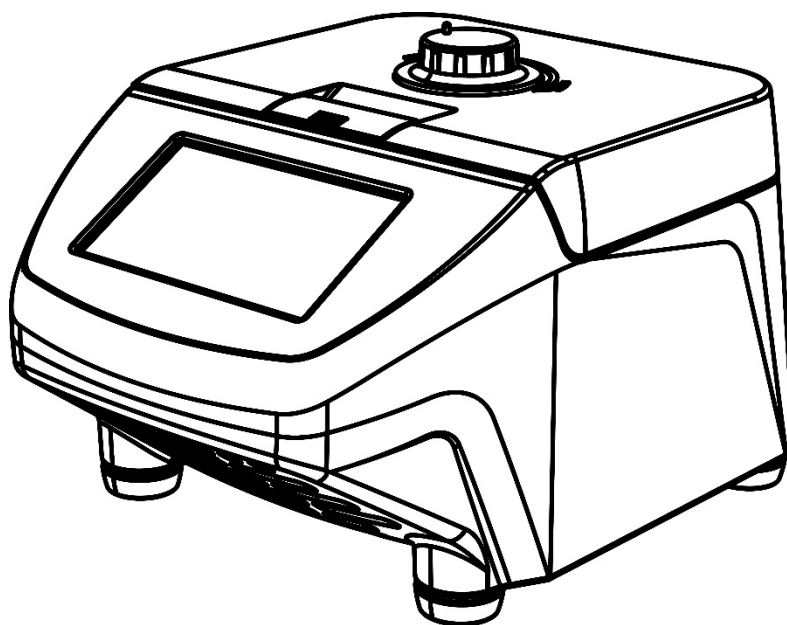

PCR Thermal Cycler (TC1000-G-Pro) User Manual



Before using PCR machine, please carefully read this user manual
for its efficient operation and safety.

CE

12302235

Ver.20221202





CONTENTS

COPYRIGHT	1
SAFETY NOTICE	2
1. INTRODUCTION	6
1.1. Intended use	6
1.2. Specifications	6
2. DECLARATION OF CONFORMITY.....	8
3. REQUIRED OPERATIONAL CONDITION	10
3.1. Basic Operational Conditions	10
3.2. Transport and storage condition.....	10
4. INSTALLATION.....	11
4.1. Location	11
4.2. Connection of the power cord and grounding.....	11
5. STRUCTURE	12
5.1. Installing the thermo block.....	14
5.2. Heated lid.....	15





6. OPERATION MANUAL	15
6.1. Pre-start check	15
6.2. Start-up	16
6.3. Functions	18
7. CREATION OF THE EXPERIMENTAL METHODS	30
7.1. Experimental method creation Process	30
7.2. Examples of typical PCR experiments.....	31
8. INSTRUCTIONS FOR USING THE UPPER-COMPUTER.....	32
8.1. FUNCTIONS	33
8.2. Creation of experimental methods.....	37
9. TROUBLE SHOOTING.....	41





COPYRIGHT

No part of this manual may be reproduced or transmitted without prior written permission of original manufacturer.

The contents of this document are subject to change without notice.







SAFETY NOTICE

Common safe type cautions

Carefully read the following safety precautions for a thorough understanding.

- Follow the instructions and procedures described in this manual to operate this instrument safely.
- Carefully read all safety messages in this manual and the safety instructions on the instrument.
- Safety messages are labeled as indicated below. They are in combination with signal words of “WARNING” and “CAUTION” with the safety alert symbol  to call your attention to items or operations that could be dangerous to you or other persons using this instrument. The definitions of signal words are as follows:

	<p>WARNING: Personal Danger</p> <p>Warning notes indicate any condition or practice, which if not strictly observed, could result in personal injury or possible death.</p>
--	--



**CAUTION: Possible damage to instrument**

Caution notes indicate any condition or practice, which if not strictly observed or remedied, could result in damage or destruction of the instrument.

NOTE: Notes indicate an area or subject of special merit, emphasizing either the function of the product or common errors in operation or maintenance.

- Do not operate this instrument in any manner not described in this manual. When encountering trouble with this instrument, ASK FOR HELP from original manufacturer or authorized distributors.
- The precautions described in this manual are carefully developed in an attempt to cover all the possible risks. However, it is also important that you are alert for unexpected incidents. Please operate with care.

**WARNING:**

- This instrument is not explosion-proof. Never use explosive or flammable samples.
- Do not install the instrument in or near places where flammable gases are generated, or chemicals are stored.
- Do not place dangerous material within 30cm around the



instrument.

- Make sure to incorporate appropriate safety measures before using samples that are toxic, radioactive or contaminated with pathogenic micro-organisms.
- If the instrument and/or accessories that have been contaminated by solutions with toxic, radioactive or pathogenic materials are free from contamination; clean it according to the decontamination procedure.
- If you require services at site, please sterilize and decontaminate it in advance, and then describe in detail the hazardous substances used to the service center involved.
- Do not handle the power cord or turn on or off the POWER switch with wet hands to avoid electrical shocks.
- Do not repair, disassemble the instrument or carry out other maintenance without proper authorization. Please contact the service center of the manufacturer or nearest distributor if you need such service.
- Do not operate the product in any manner not described in this User Manual.
- This product contains heating components, please avoid scalding injury.

**CAUTION: Possible damage to instrument**

- This instrument must be located on solid and level workbench top for indoor use.
- Ensure there is sufficient distance with the surrounding equipment and there is enough air circulation of the vent.
- When closing the cover, do not put your hands between the upper cover and the casing, preventing the pinch.
- Do not move or relocate the product when it is running.
- If fluid spills out, please promptly clean and dry with a dry cloth to avoid sample contamination.
- When the instrument is not in operation, keep the machine cover open, or arbitrary open the cover will affect the experiment results.
- When the instrument is in operation, the sudden loss of power will affect results.
- When in doubt or have any trouble with this product, ASK FOR HELP.
- Vibrations are likely to damage the product, contact our service center if abnormality observed.

1. INTRODUCTION

1.1. Intended use

PCR Thermo cycler is widely used in biology, medicine, food industry, forensic science, biotechnology, environmental science, microbiology, clinical diagnosis, epidemiology, genetics, gene chips, genetic testing, gene cloning, and other fields that need gene expression instrument. Operator should be trained before using the product. Detailed operation, please refer to the User Manual below.

1.2. Specifications

Specifications	TC1000-G-Pro
Sample Capacity	0.2ml PCR tubes×96, PCR-8-strips×12 or 96well plate ×1
Heating Temperature Range	0~105°C
Lid Temperature Range	30~115°C, when the module has been set at <30°C, automatic closure of the hot lid
Temperature Display Accuracy	0.1°C
Temperature Accuracy	±0.1°C



Temperature Uniformity (35-72°C)	±0.2°C
Max. Heating/Cooling Rate	5°C/Sec
Gradient Temperature Setting Range	30~105°C
Gradient Range	1~42°C, Turn off gradient on input 0
Display	7"LCD 1024×600mm
Temperature control	Temperature control in areas
Back office systems	Password protected
User-defined file systems	Up to 30 steps in a single program, ≤ 99 cycles, Storage of >20000+files (USB Flash)
PC connection	Yes
Power-off Protection	Yes
Power Supply	AC 100~120V/200~240V 50/60Hz
Power	600W
External communication interface	WIFI、USB2.0
Dimension[W×D×H]	280×370×250mm
Weight	9.5Kg





2. DECLARATION OF CONFORMITY

In compliance with the following safety standards:

EN 61010-1

EN 61010-2-020

EN 61010-2-101

In compliance with the following EMC standards:

EN 61326-1/FCCPart15Subpart B/ IECS 001

EN 61326-2-6:2006

Associated EU guidelines:

EMC guidelines:2004/108/EC

LVD guidelines: 2006/95/EC

This ISM device complies with Canadian ICES-001.

Cet appareil ISM est conforme à la norme NMB-001 du Canada.



Changes or modifications not expressly approved by the party responsible for compliance could void the user's authority to operate the equipment.

NOTE: This equipment has been tested and found to comply with the limits for a Class A digital device, pursuant to Part 15 of the FCC Rules. These limits are designed to provide reasonable protection against harmful interference when the equipment is operated in a commercial environment. This equipment generates, uses, and can radiate radio frequency energy and, if not installed and used in accordance with the instruction manual, may cause harmful interference to radio communications. Operation of this equipment in a residential area is likely to cause harmful interference in which case the user will be required to correct the interference at his own expense.





3. REQUIRED OPERATIONAL CONDITION

To ensure the longevity and safety of the instrument, please ensure basic environmental conditions and transport and storage conditions prior to operation.

3.1. Basic Operational Conditions

- Power: 100 ~ 120V/200 ~ 240V, 50/60Hz
- Ambient temperature: 10°C ~ 30°C.
- Relative humidity: ≤70%.
- No vibration and airflow around.
- No airborne dust with charge, explosive and corrosive gases around.

3.2. Transport and storage condition

- Storage temperature: -20°C ~ 55°C.
- Relative humidity: ≤80%.





4. INSTALLATION

This section describes the instructions that you should abide when installing the instrument to ensure your safety, and the optimum performance of the instrument

	<p>WARNING:</p> <ul style="list-style-type: none"> ● Improper power supply may damage instrument. ● Make sure the power source conforms to the requirement before connecting.
--	--

4.1. Location

- Place the instrument on a firm, flat and level bench top, ensure the four feet of this instrument stand on the table firmly. Avoid slippery surfaces or surfaces prone to vibration.
- The recommended ambient temperature is 20°C±5°C. Avoid temperatures over 30 °C or direct exposure to sunlight.
- Keep clear of the instrument at least 10 cm on both sides and at least 30 cm behind it to guarantee the cooling efficiency.
- Keep away from heat source or liquid.

4.2. Connection of the power cord and grounding

	<p>WARNING:</p> <ul style="list-style-type: none"> ● To avoid electrical shocks, ensure your hands are dry when touching the power cord. ● This instrument must be grounded properly.
--	--

A power outlet rated for 10A or above, with proper earth protection and in compliance with municipal safety requirements is compulsory.

5. STRUCTURE

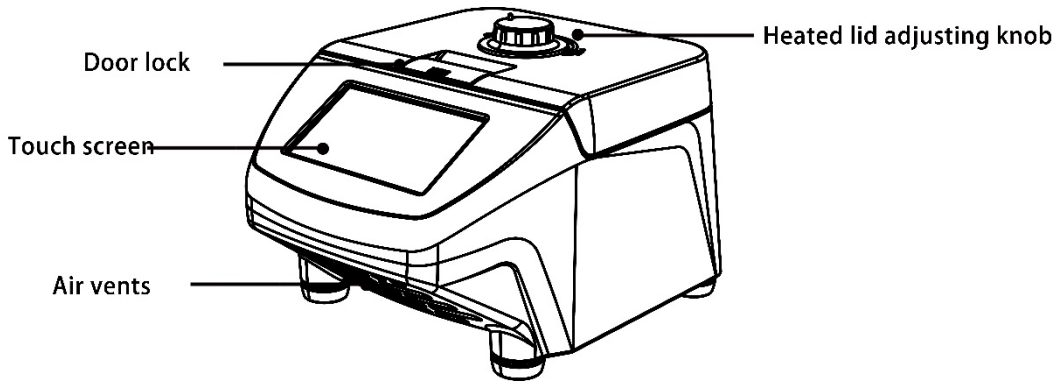

Figure 5-1 Front view of the instrument

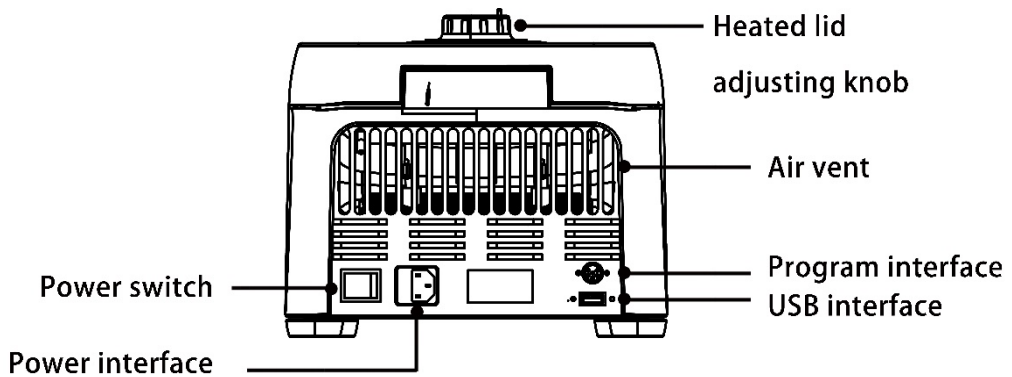

Figure 5-2 Back view of the instrument





Heated lid adjusting knob: Adjust the height of heated lid to accommodate different reaction tubes.

LCD touch screen: Parameters setting and display

Door lock: Open or lock the cover

Air vents: Ventilation

Power switch: Turn on /off the power

Power interface: Connect the power cord

Program Interface: For service

USB Interface: For service



5.1. Installing the thermo block

Before power on, please make sure the thermo block has been installed correctly.

Installing methods: Put the thermo block vertically into the main unit and ensure good contact between the Thermo block and the main unit.

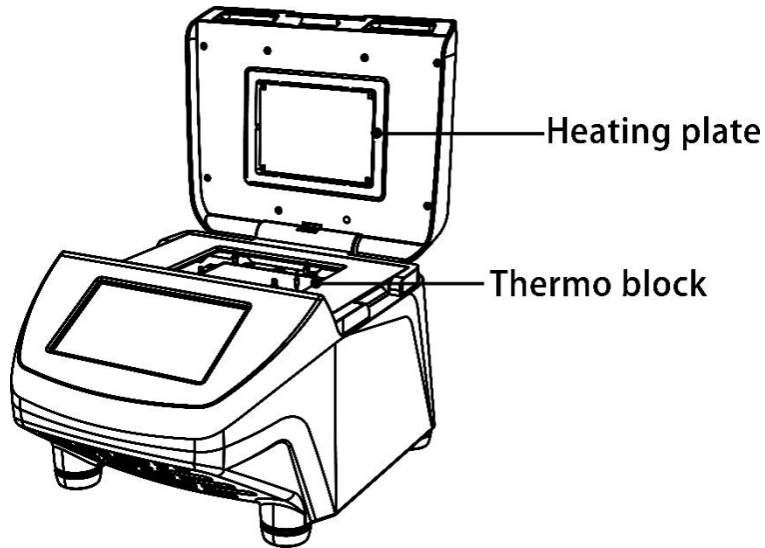

Heating plate: Heat for the heated lid

Thermo block: Load the sample tubes or a PCR plate



CAUTION!

- Risk of burns from the hot surface.
- Risk of burns form hot thermo block and hot heating plate when the heated lid is open.



5.2 Notes on hot lids

- 1) Before closing the hot lid, ensure that the heating module is fitted with a sample.
- 2) Before starting the programme, make sure that the top lid locking catch is locked and that the hot lid is pressed down on the sample.
- 3) Do not place your fingers between the heating lid and the apparatus when closing the heating lid as this may cause injury.
- 4) Hot lid adjustment knob: The hot lid adjustment knob allows you to adjust the different heights of the hot lid to match different sample tubes. Turn clockwise to press the hot lid downwards and counterclockwise to lift it upwards.

6. OPERATION MANUAL

6.1 Pre-start check

Before using a PCR thermal cycler for the first time, ensure that the following requirements are met:

- 1) The equipment is correctly connected.
- 2) Unit is undamaged.



- 3) Free circulation of air around ventilation slots.

Before plugging in and powering up the instrument, check the following:

- 1) Check that the power supply is compatible with the voltage required by the instrument.
- 2) Make sure the power cord plug is securely inserted into the power outlet.
- 3) Reliable earthing of the power cable.
- 4) Module makes contact.

6.2. Start-up

- 1) When the power switch is turned on, the instrument will emit a beep to indicate that the power is on
- 2) The instrument starts a self-test. The self-test takes about 20s, please be patient.
- 3) After the progress bar shows 100%, if each sensor is normal, the last prompt in the upper left corner will be "self check through" indicating that the self-test has passed and the system will automatically jump to the home page; if the progress bar reaches 100%, the last prompt in the upper left corner will be "The self-test failed! If the progress bar reaches 100%, the last prompt in the top left corner is



"The self-test failed!", which means that the self-test has failed and contact the manufacturer.



4) The system automatically jumps to the "Home" page after passing the self-test.

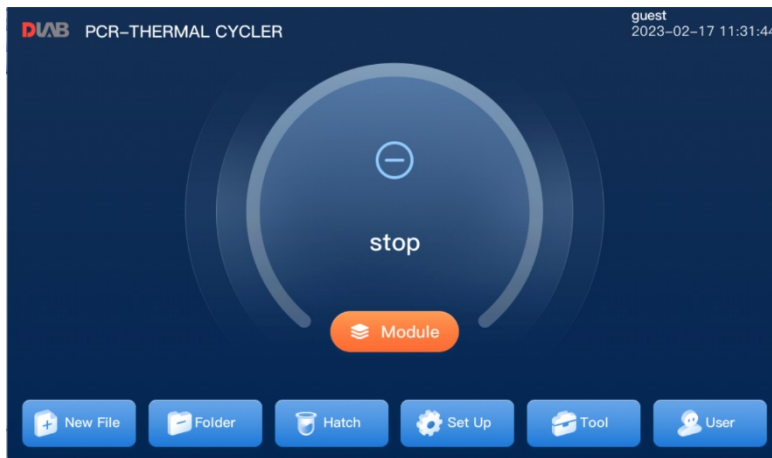

5) When a program is running, the "Home" screen appears as follows.



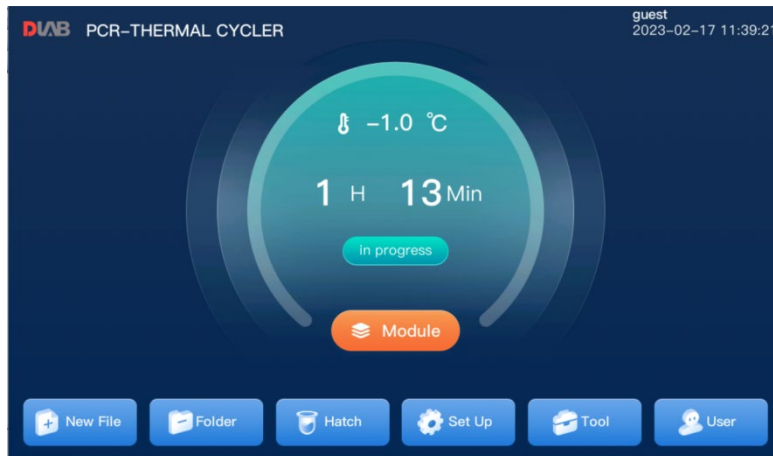

6.3. Functions

6.3.1 New file

Press  enter the New File interface, where you can create a new experimental program. On the right side of the interface, users can customize the file name (note that the file name does not support Chinese name), reagent volume, hot lid temperature and turn on/off the hot lid heating. Note that the hot lid temperature setting range is from 30 to 115°C. The system defaults to hot lid on and 110°C.



78.0 °C
00:00:30 : To set the temperature and time for the current step, e.g. 78°C, 30s, enter 78 after clicking the temperature button (note that the temperature can be set in the range 0 to 105°C) and enter 30 in the seconds position after clicking the time button (00:00:30).

+Temp : Add steps, up to 30 steps.

+Cycle : Add loops with a maximum of 99 loops.

Delete : Delete steps, one for each click.

1
x 29 : For jumping loops between steps, e.g. 29 loops between step 1 and step 2 as shown, click the first button below GOTO and enter 1, the second button below GOTO and enter 29.

Clear All : Clear all steps to keep only the default 1 step.

Save : Save the created experiment program.



- Note: When a newly created experiment program file has the same name as an already saved experiment program file, the newly created experiment program file will overwrite the previously saved experiment program file.

Advance: The setup screen is shown below.

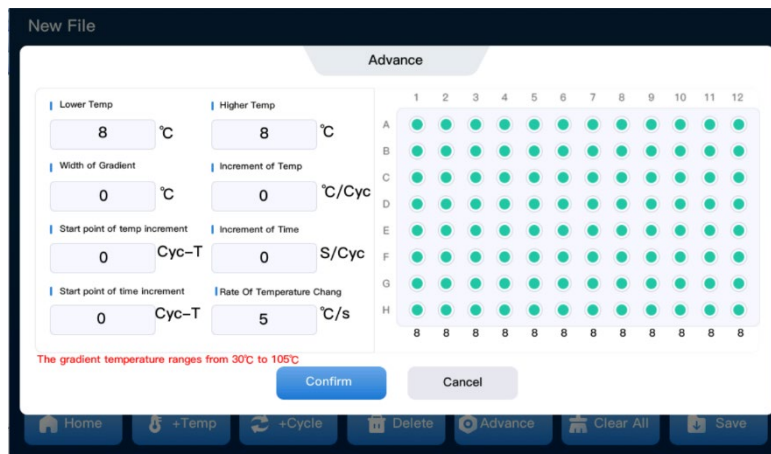

Lower Temp 8 °C Temperature low point: The temperature range can be set from 0 to 105°C.

Gradient settings are not supported at temperatures <30°C.

Higher Temp 8 °C Temperature high point: The temperature range can be set from 30 to 105°C.

Width of Gradient 0 °C Gradient width: The gradient range can be set from 0 to 42°C. Enter 0 to cancel the gradient.

Increment of Temp 0 °C/Cyc Temperature increment: The amount by which the temperature increases or decreases for each cycle of the current step, the temperature increment can



be set in the range -10 to +10°C/Cycle.

Start point of temp increment
 0 Cyc-T Temperature increment on: Set the temperature increment to be turned on in the first few cycles, the range is 0 to 99Cycle.

Increment of Time
 0 S/Cyc Time increment: the amount by which each cycle time is increased or decreased in the current step, the time increment can be set in the range -600 to +600 S/Cyc.

Start point of time increment
 0 Cyc-T Time increment on: Set the time increment to be turned on in the first few cycles, the range is 0 to 99Cycle.

Rate Of Temperature Chang
 5 °C/s Variable temperature rate: The rate of temperature increase from low to high, can be set in the range of 0 to 5°C/s.

Run: The running screen is shown below. The strip of lights at the top of the screen will have a dynamic effect when the experimental program is running.

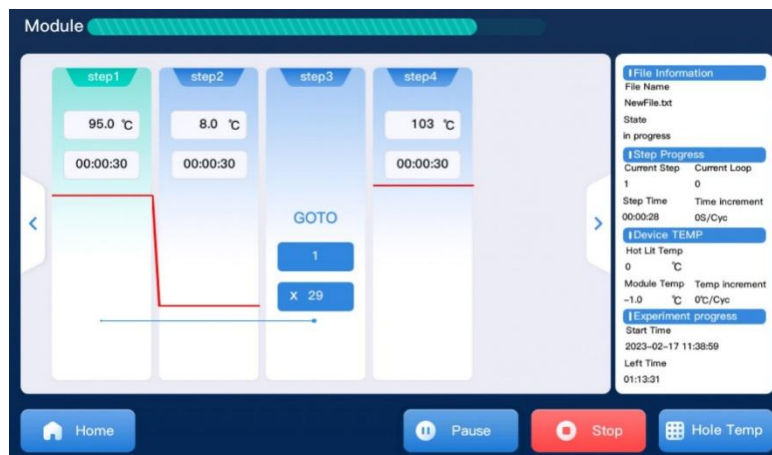



 **Pause** : Pause the running experimental program.

 **Stop** : End the running experimental program.

 **Hole Temp** : View the real-time bore temperature of the module.

 **Home** : Return to the main page.

6.3.2 File management

Press  **Folder** Access the file library. When the system is in the guest user, the experimental program files created are saved in the "public" folder; when logged into the registered account, the experimental program files will automatically be saved in the "private" file and the same name of your account in the folder. The location of the U disk is the user inserted into the U disk, whether the system is in the guest user or their own registered private account, you can save the experimental program files to the U disk. Note that the experimental program files in the private folder, only when logged into the folder corresponding to the account can see, if you want to view the experimental program files created without logging into the private account, you can copy the files in the private folder to the public folder, then all users can see the experimental program files.

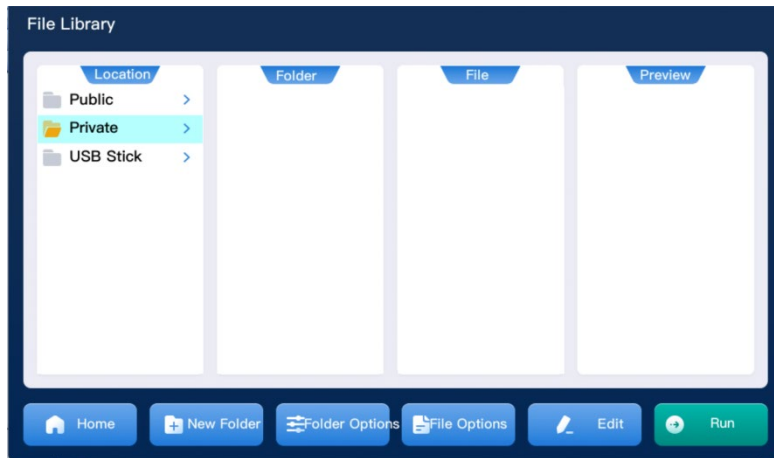

6.3.3 Incubation function

Click on the home page enter the 'Hatching Wizard' screen.

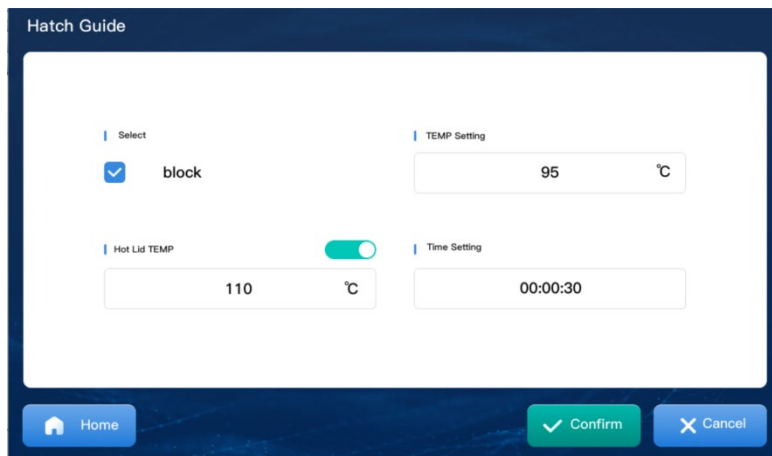

After setting the start temperature and time as well as whether the hot lid is on and the hot lid temperature, press to start running the program. step2 temperature and time are default 4°C refrigeration does not need to be set. Note that the hot cover defaults to the start state and the temperature is 110°C. The light



strip at the top of the screen will have a dynamic effect while the program is running. During the experiment the user can view the current temperature of the hot lid and module by looking at the device temperature bar on the right hand side of the page and the experiment progress bar to see when the experiment started and the time remaining in the current step.



Stop : End the currently running experimental program.

Home : Return to the home page.

6.3.4 System settings

Click on the home page enter the 'Hatching Wizard' screen.



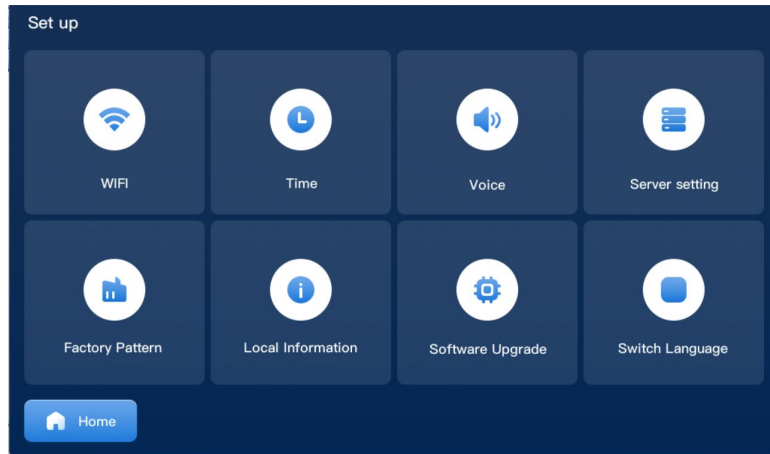

: Connect to a nearby WIFI and display the currently connected WIFI at the top of the screen.

: Set the time zone and the current date.

: Switching on or off the "key tone", "alarm tone", "programme reception tone", "temperature arrival tone ". When is checked, the sound is on, otherwise the sound is off.

: For communication with the host computer.

: Factory mode is used for instrument calibration.

: View local information including "local name", "version", "serial number", "desktop version".

: Screen upgrade. Insert the USB stick for upgrade in the power on state (note that you must insert a USB stick in FAT32 format and the memory is not larger than



16G). Click the button, the system will be upgraded automatically. After the upgrade is completed, turn off the power and turn on the computer again to complete the upgrade. The upgrade screen can also be inserted into the U disk in the off state, and the system will automatically upgrade when the power is turned on, the upgrade is completed by turning off the instrument and unplugging the U disk and turning on the power again to complete the upgrade.

: The screen displays the language settings and the user can choose between "Chinese" and "English" to suit their needs.

 Home: Return to the main page.

6.3.5 Tools

Click on the home page  enter the 'Hatching Wizard' screen.

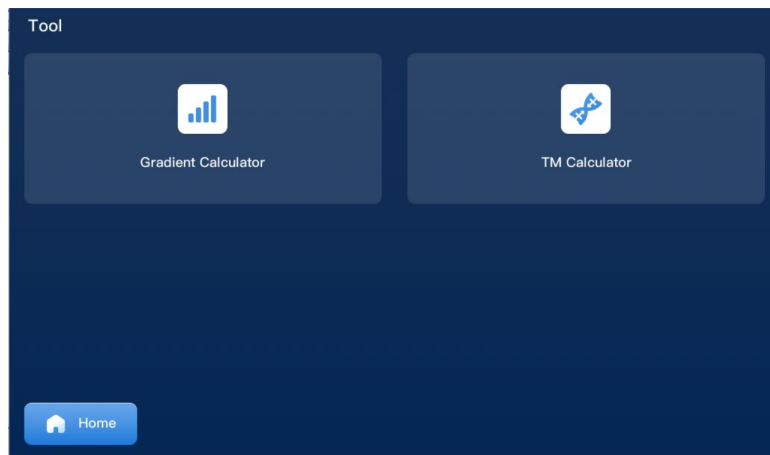

: Gradient calculator, after entering the temperature low and temperature high,



the gradient width is automatically calculated, note that the gradient width range is 0 to 42°C. When the gradient width is 0, the gradient is turned off. The hole temperature for each column can be viewed on the right hand side.

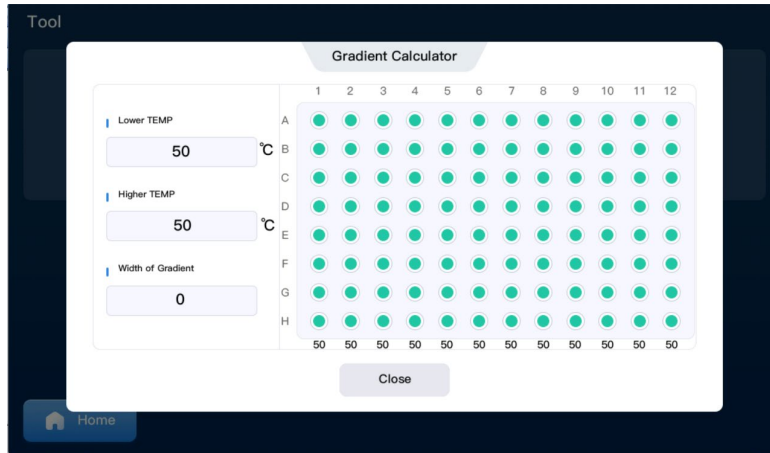

: TM calculator that automatically calculates TM values for primers after entering the sodium ion concentration and primer sequence.

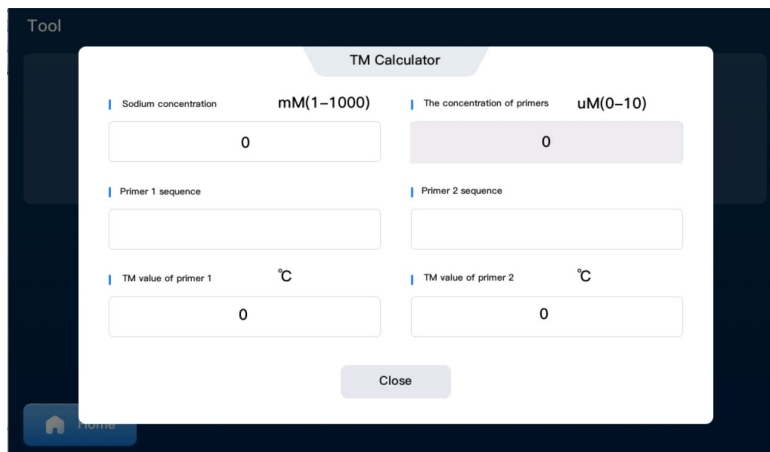

Home: Return to the main page.

6.3.6 User settings

Click on the home page Enter the user management interface. The system defaults to "guest" as the public account, no login is required. In the user management interface, the system will have an administrator account by default, i.e. "admin". The default password for this account is "admin", users can also log in to the account and change the password (if the "admin" account forgets the password, you can only upgrade the touch screen program to restore the default password for the account). Note that only the administrator account "admin" can delete the registered account (except for the "admin" account), the rest of the accounts only have registration rights, no account deletion rights. The registered account name does not support Chinese names.

User Name	Permission	Create Time
admin	administrator	2023-02-17 11:27:25

Navigation buttons: Home, Password, Delete, Logout, Log in, Log on

Home : Back to home page

Password : Password change for registered accounts

Delete : Delete a registered account

Logout : Login out registered account

Log in : Login on registered account

Log on : Register an account

7. CREATION OF THE EXPERIMENTAL METHODS

Due to the different purposes of experiments, the experimental methods provided in this instruction manual are for reference only, and the actual operation of the experimenter needs to be completed according to the specific experimental purposes to create the experimental procedures.

7.1. Experimental method creation Process

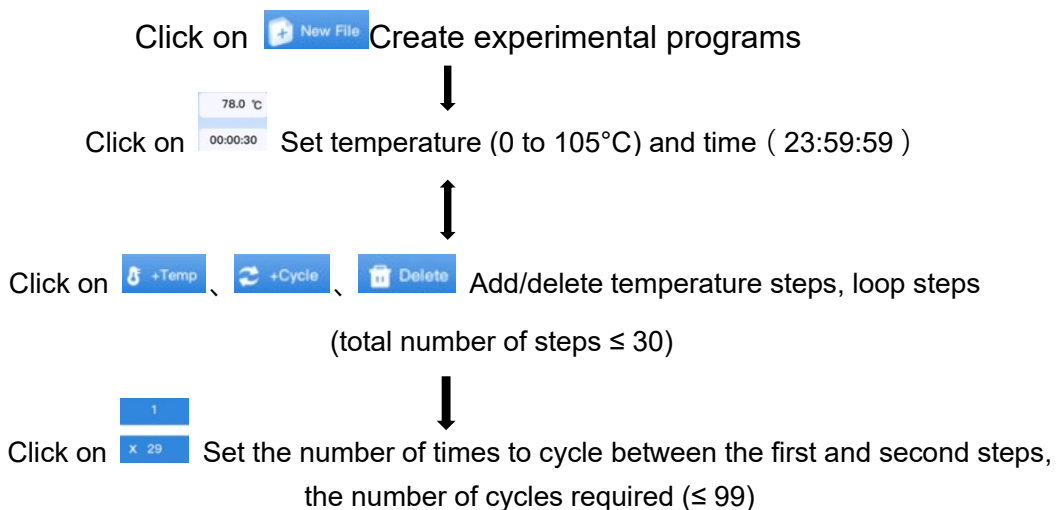



Click on  Set parameters such as gradient, temperature increment, time increment, temperature increment on, time increment on and temperature change rate



Click on  Set the file name (Chinese names are not supported)



Click on  Set reagent volume, default 10 μ L



Click on  Turn on/off the hot lid, set the hot lid temperature (30 to 115°C)
Default hot lid on, temperature 110°C



Click on  save the current experimental program



Click on  run the current experimental program

7.2. Examples of typical PCR experiments

1) Pre-denaturation 96°C, 5min: enter 96 in the STEP1 temperature position and 5 in the time minute position (00:05:00).

2) Denaturation 95°C, 30s: click on  to add a step2 and enter 95 for the





temperature position and 30 for the time seconds position (00:00:30).



3) Annealing 55°C, 30s: click on  to add a step3 and enter 55 for the temperature position and 30 for the time seconds position (00:00:30).

4) Extension 72°C, 30s, step2 to step4 for 30 cycles. click on  to add a step4. Enter 72 for the temperature position and 30 for the time seconds position (00:00:30).

5) Click on  to add a loop step, click on the first button below GOTO and enter the number 2, click on the second button below GOTO and enter the number 30.

6) Continue at 72°C for 10min: click on  to add a step5 and enter 55 for the temperature position and 10 for the time minute position (00:10:00).

7) Refrigerated at a low temperature of 4°C for 24h: click on  to add a STEP 6. Enter 4 for the temperature position and 12 for the time hour position (12:00:00).

8) Click on  Save the experimental program or click on  to run Experimental Program.

8. INSTRUCTIONS FOR USING THE UPPER-COMPUTER

The PC software that accompanies the PCR is installed on the PC prior to operation and the PCR instrument must be on the same network environment as the PC.

Double click with the mouse (or right click to open)  menu.

8.1. Functions

8.1.1 Equipment management interface

Selecting  software enters the "Device Management" screen by default.

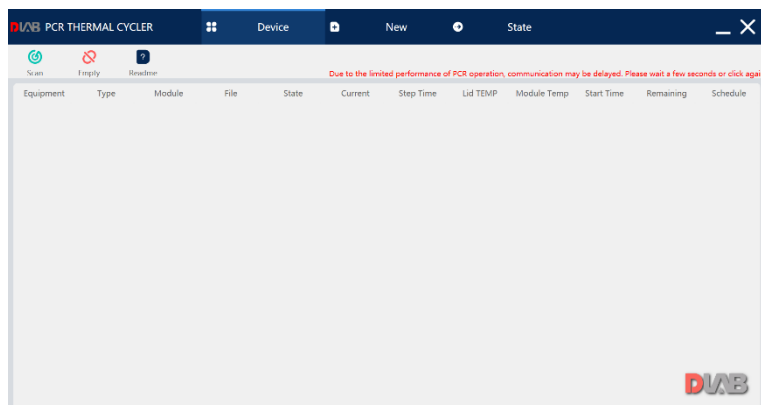

Window tools : Minimize, Maximize/Restore and Close in that order.

Automatic scanning : Search for nearby instruments, note that the instrument must be on the same network as the computer in order to be searched.

Emptying : Clear all instruments searched for.

Operating Instructions : Instruction on the operation of the software.

8.1.2 New document screen

Click on **New** Go to the experimental program editing screen.

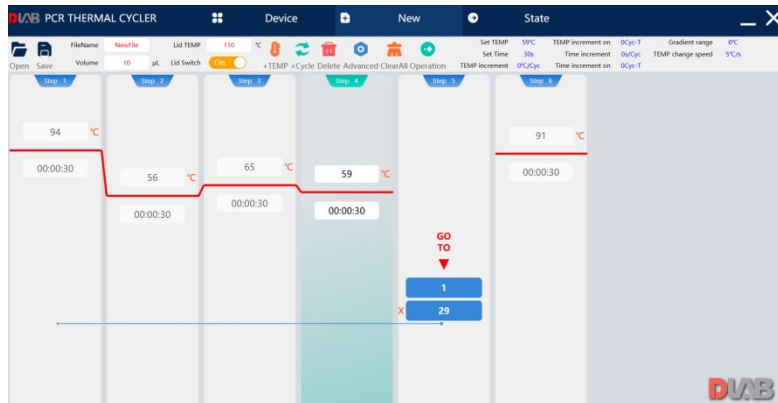

Open the file : Open the saved history of the experiment program.

Save file : Save the experimental program, the file name does not support Chinese.

FileName : Edit the name of the experiment program, note that Chinese names are not supported.

Volume μL : Set the actual volume, default 20 μL .

Lid TEMP $^{\circ}\text{C}$: Set the hot lid temperature, the range is settable from 30-115 $^{\circ}\text{C}$. The default for the hot lid is 110 $^{\circ}\text{C}$.

Lid Switch On: Hot cover on/off, default hot cover is on.

+ Temperature steps : Add temperature steps for a total of ≤ 30 steps.



+ Cycle steps : Add cycle steps with a cycle count of ≤ 99 .

Delete : Delete step, tap to delete a step.

Clear all : Delete all steps and keep only the default step 1.

: To set the temperature and time, e.g. 90°C, 30s, enter 90 for the temperature position (value range 0 to 105°C can be entered). For the time seconds position

enter 30 (00:00:30). : For jumping cycles between steps, e.g. 29 cycles between steps 1 and 2, click on the first button below GO TO and enter the number 1, click on the second button below GO TO and enter the number 29.

Advanced settings : First click on the step where you need to add advanced settings, then click on Advanced Settings to enter the Advanced Settings screen.

For example, to add advanced settings in step 2, first click on step 2 and then click on make advanced settings.

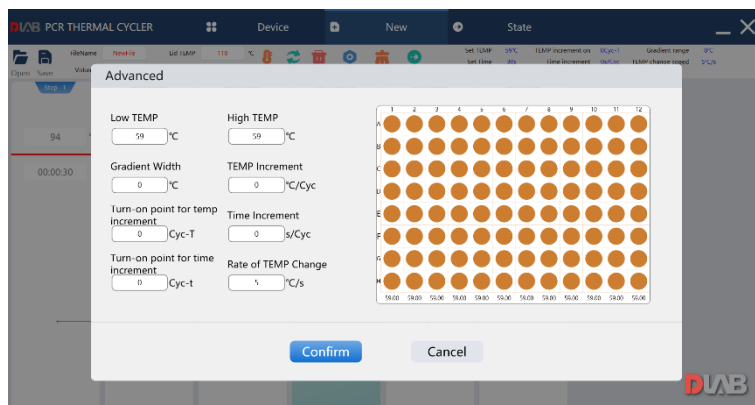

: Set the temperature low TEMP point with an input value range of 0 to 105°C. A



gradient temperature can be set only for $\geq 30^{\circ}\text{C}$.

High TEMP $^{\circ}\text{C}$: Set the temperature high point with an input value range of 30 to 105°C .

Gradient Width $^{\circ}\text{C}$: The gradient can be set to range from 0 to 42°C . The gradient is cancelled when 0 is entered.

TEMP Increment $^{\circ}\text{C}/\text{Cyc}$: For each cycle, the temperature of the current step increases or decreases and the temperature increment can be set in the range -10 to $+10^{\circ}\text{C}/\text{Cycle}$.

Turn-on point for temp increment Cyc-T : Indicates the number of cycles in which the temperature increment is turned on, the range can be set from 1 to 99Cycle, enter 0 to turn off.

Time Increment s/Cyc : For each cycle, the step time is increased or decreased by an amount and the time extension can be set in the range -600 to $+600\text{s}/\text{Cyc}$.

Turn-on point for time increment Cyc-t : Indicates the time increment at which the cycle is turned on, can be set in the range 1 to 99Cycle, enter 0 to turn off.

Rate of TEMP Change $^{\circ}\text{C}/\text{s}$: The rate of temperature change from low to high temperature can be set in the range of 0 to $5^{\circ}\text{C}/\text{s}$.

Running  : Run the program.

8.1.3 Operational status screen

Click on  View the current running status of the experimental program.

On the right side of the button you can view the current instrument run.



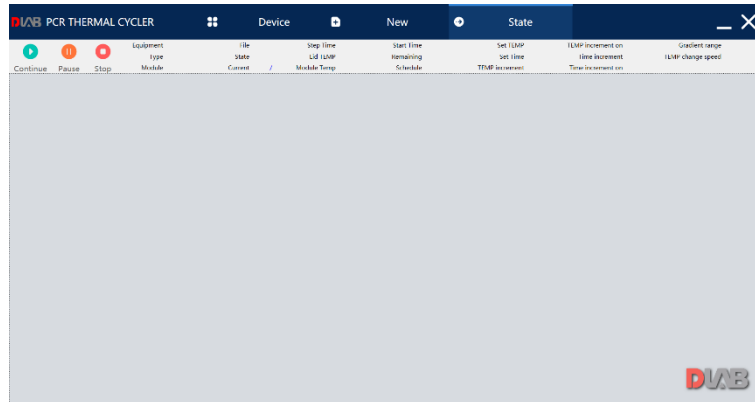

Suspension of operation : Pause the currently running experimental program.

Stop running : End the currently running experimental program.

Continue running : When the program is paused, clicking this button will resume the previous program.

8.2. Creation of experimental methods

Due to the different purposes of the experiments, the experimental methods provided in this instruction manual are for reference only, and the actual operation of the experimenter needs to be completed according to the specific experimental purposes to create the experimental procedures.

8.2.1 Experimental method creation process





Click on Auto Scan  Search for nearby instruments



Equipment	Type	Module	File	State	Current	Step Time	Lid TEMP	Module Temp	Start Time	Remaining	Schedule
-----------	------	--------	------	-------	---------	-----------	----------	-------------	------------	-----------	----------

Click to select the instrument for the experiment



Click on  Set temperature (0 to 105°C) and time (23:59:59)



Click on  Add/delete temperature steps, loop steps (total



Click on  Set the number of times to cycle between the first and second steps, the number of cycles required (≤ 99)



Click on Advanced Settings  Set gradient, temperature increment, time increment, temperature increment on, time increment on, variable temperature rate change rate.



Click on  Set the file name (Chinese names are not supported)



Click on  Set reagent volume, default 20 μ L





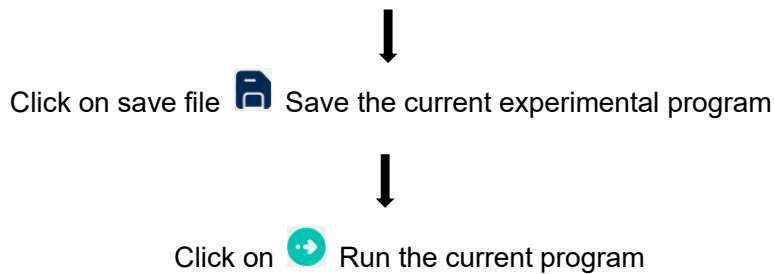

Click on  Turn on/off the hot lid and set the hot lid temperature (30 to 115°C).

Default hot lid on







8.2.2 Examples of typical PCR experimental methods

- 1) Example of typical PCR experimental method Pre-denaturation 96°C, 5min: Enter 96 in the temperature position in step 1 and 5 in the time minutes position (00:05:00).
- 2) Denaturation 95°C, 30s. Click on  Add a step 2 and enter 95 for the temperature position and 30 for the time seconds position (00:00:30).
- 3) Annealing 55°C, 30s: Click on  Add a step 3 and enter 55 for the temperature position and 30 for the time seconds position (00:00:30).
- 4) Extension 72°C, 30s, 30 cycles of steps 2 to 4. Click on  add a step 4. enter 72 for the temperature position and 30 for the time seconds position (00:00:30).
- 5) Click on  add a loop step, click on the first button below GOTO and enter 2, click on the second button below GOTO and enter 30.
- 6) Continue at 72°C for 10min: Click on  add a step 5 and enter 55 for the temperature position and 10 for the time minute position (00:10:00).



7) Refrigerated at low temperature 4°C for 12h: Click on  add a step 6, enter 4 for the temperature position and 12 for the time hour position (12:00:00).

8) Click on  save the experiment program or click on  run the experimental program.

Note: As different brands of instruments have their own temperature control characteristics (including: heating and cooling rates, stability, volatility, etc.), and as biological experiments are inherently unstable and susceptible to other factors, just because the same procedure will run successfully on one instrument does not mean that the same results will be obtained on another. Therefore, in order to achieve the desired experimental results, please adapt the program to suit different instruments.

9. TROUBLE SHOOTING

	<p>CAUTION!</p> <ul style="list-style-type: none"> ● When Power on, if you find the phenomenon of abnormal sound, abnormal display, failure alerts, fail in self-test, etc, please turn off the power and contact the manufacturer immediately. ● During the warranty period it is strictly forbidden for the user to open the shell of the instrument to check by himself, if a fault occurs in the table that requires opening the shell to check it should contact the manufacturer in time.
--	--

Index	Symptom	Cause	Measure
1	Instruments can't be power on	The power line is unplugged	Check whether the power line is unplugged Check whether the fuse is broken or loose.
		Others	Contact the manufacturer
2	During the self-test, Sensor#1, Sensor#2 and	The thermo block is not installed	Install the thermo block
		The thermo block is	Power off, Install the



	Sensor#3 show abnormal.	not contact well with the main unit.	thermo block again, then power on.
		Others	Contact the manufacturer
3	TEC#1 heat/cool, TEC#2 heat/cool, TEC#3 heat/cool items show abnormal during power-on self-test	The thermo block is not installed	Install the thermo block
		The thermo block is not contact well with the main unit.	Power off, Install the thermo block again, then power on.
		Damaged heating module components	Contact the manufacturer
4	Hot Lid item shows abnormal during self-test	Damaged heating module components	Power off, Install the thermo block again, then power on.
			Contact the manufacturer
5	Self-test, TE1 Ref, TE2 Ref, TE3 Ref--error	Ventilation holes are blocked Cooling chip damaged	Clear blockage of ventilation holes Contact the manufacturer



6	Heated lid cannot heat	The heated lid is closed at the system setting interface.	Open the heated lid, Set a temperature.
		The heated lid damaged	Contact the manufacturer
7	The reagent in the reaction tube evaporates	The heated lid is closed	Open the heated lid, Set a temperature.
		The reaction tube was placed unevenly	Try to place symmetrically
		The cap of the reaction tube is not tight fit	Fit tightly before put into the instrument





Thermal Control



CONTACT US



DLAB Scientific Co., Ltd

Yu An Road 31, Beijing Airport Economic core zone,

Shun yi District, Beijing, China 101318

Tel: 86-10- 85653451/52/53

Fax: 86-10-85653383

E- mail: info@dlabsci.com

web: www.dlabsci.com

