

ANALIZADOR MULTIPARÁMETRO NAHITA  
NAHITA MULTIPARAMETER ANALYZER  
ANALYSEUR MULTIPARAMÉTRIQUE NAHITA

Nahita



Este manual es parte inseparable del aparato por lo que debe estar disponible a todos los usuarios del equipo. Le recomendamos leer atentamente el presente manual y seguir rigurosamente los procedimientos de uso para obtener las máximas prestaciones y una mayor duración del mismo.

*This manual should be available for all users of these equipments. To get the best results and a higher duration of this equipment it is advisable to read carefully this manual and follow the processes of use.*

*Ce manuel est une partie indissociable de l'appareil et doit être mis à la disposition de tous les utilisateurs de l'équipement. Nous vous recommandons de lire attentivement ce manuel et de suivre scrupuleusement les procédures d'utilisation afin d'obtenir des performances maximales et une plus longue durée de vie de l'appareil.*

Spanish .....	1-60
English .....	61-119
French .....	120-178

## TABLE OF CONTENTS

1 Introduction.....	63
1.1 Introduction .....	63
1.2 Technical Specification.....	64
1.3 Function Introduction .....	66
2 Safety Notices .....	70
3 Terms Explanation.....	70
4 Overview and Installation.....	71
4.2 Instrument Installation.....	73
4.2.1 Electrodes Stand Installation .....	73
4.2.2 Electrodes Connection .....	73
5 Instrument Operation.....	74
5.1 Switch On/Off.....	74
5.2 Screen Icons .....	74
5.3 Methods Management.....	76
5.3.1 Update Method .....	76
5.3.2 Create a new Method .....	77
5.3.3 Delete a Method.....	77
5.3.4 Save and Load a Method .....	77
5.4 Parameter Setting .....	77
5.4.1 Tutorial setting .....	78
5.4.2 Method basic information .....	78
5.4.3 Select parameters .....	78
5.4.4 Reading Mode Settings.....	79
5.4.5 pH parameter setting .....	80
5.4.6 pX/ISE parameter settings.....	83
5.4.7 ORP Parameter Settings .....	86
5.4.8 EC Parameter Settings.....	87
5.4.9 Dissolved Oxygen Parameter Settings .....	91
5.4.10 Temperature Parameter Settings.....	93
5.4.11 Data Management Settings .....	93
5.4.12 Output option.....	94
5.4.13 User management .....	94
5.4.14 System Parameter Settings .....	94

5.5 pH Measurement .....	95
5.5.1 Calibration Preparation .....	95
5.5.2 Standards group selection .....	95
5.5.3 pH Calibration .....	95
5.5.4 pH Measurement .....	96
5.6 Ion measurement .....	96
5.6.1 Preparation .....	96
5.6.2 Direct reading measurement .....	99
5.6.3 Standard addition method .....	101
5.7 ORP Measurements .....	106
5.7.1 Calibration Preparation .....	106
5.7.2 ORP Calibration .....	106
5.7.3 ORP Measurement .....	107
5.8 Conductivity Measurement .....	107
5.8.1 Cell Constant Input .....	107
5.8.2 Calibration Preparation .....	108
5.8.3 Conductivity Calibration .....	108
5.8.4 Conductivity Measurement .....	109
5.9 TDS Measurements .....	110
5.9.1 TDS conversion factor .....	110
5.9.2 TDS Measurements .....	111
5.10 Salinity Measurement .....	112
5.11 Resistivity Measurement .....	112
5.12 Ash Measurement .....	112
5.12.1 White Sugar Ash .....	112
5.12.2 Fructose Glucose Syrup Ash .....	112
5.12.3 Blank Measurement .....	113
5.12.4 White Sugar Ash Measurement .....	113
5.12.5 Fructose Glucose Syrup Ash Measurement .....	113
5.13 Dissolved Oxygen Measurement .....	113
5.13.1 Calibration Preparation .....	113
5.14 Saturation Measurement .....	116
5.15 Data Management .....	116
5.15.1 Data Base .....	116
5.15.2 Statistics .....	116
6 Maintenance/Troubleshooting .....	118
6.1 Meter Maintenance .....	118
6.2 Electrodes Maintenance .....	118
6.3 Troubleshooting .....	118
7 Appendixes .....	119
Appendix 1 .....	119
Appendix 2 .....	119

# 1 INTRODUCTION

## 1.1 Introduction

The Nahita portable multiparameter analyzer is a multifunctional water quality testing device equipped with pH/ISE, conductivity, dissolved oxygen, temperature modules. The meter support measurement parameters include pH, mV, ORP, pX, ion concentration, conductivity, resistivity, TDS, salinity, dissolved oxygen concentration, dissolved oxygen saturation, temperature.

Table 1-1 Modules and measurement parameters

Module	Parameters
pH	pH, mV, ORP
ISE	pX, ion concentration
Conductivity	Resistivity, conductivity, TDS, salinity, ash
Dissolved oxygen	Dissolved oxygen current, dissolved oxygen concentration, saturation
Temperature measurement	Temperature

### General Features

- Color High contrast LCD touchscreen, 4.3 inches.
- Intelligent operation system provides features including user management, calibration management, electrode management, method management, data management, Log Management and etc.
- Multi-reading feature allows auto-read, timed-read and continuous-read.
- Automatic/Manual temperature compensation ensures accurate results.
- Auto-hold feature senses and locks the measurement endpoint.
- Data Storage: 1000 sets for each parameter (GLP-compliant).
- Data analysis feature helps user review, compare and recalculate results.
- Support for USB communication.
- Auto-power off feature effectively extends the battery service life.
- Reset feature automatically resumes all settings back to factory default options.
- IP65 waterproof. The portable meter is suitable for fields measurements and outdoor measurements.

#### pH

- 1-8 points calibration with Standard Recognition.
- Selectable pH buffer groups, including DIN, NIST, USA, MERK, JIS and GB.
- Support for pH standard group customization.
- Automatic electrode diagnosis with pH slope and offset display.

## Ion

- 1-8 points calibration.
- Selectable measurement unit, including  $\mu\text{g/L}$ ,  $\text{mg/L}$ ,  $\text{g/L}$ ,  $\text{mmol/L}$ ,  $\text{pX}$ ,  $\text{ppm}$  and  $\text{ppb}$ .
- Multi-measurement modes are supported, including Direct Reading mode, Standard Addition mode, Sample Addition mode and GRAN mode.
- Over 10 methods are built-in, including  $\text{F}^-$ ,  $\text{Cl}^-$ ,  $\text{Br}^-$ ,  $\text{I}^-$ ,  $\text{NO}_3^-$ ,  $\text{BF}_4^-$ ,  $\text{NH}_4^+$ ,  $\text{K}^+$ ,  $\text{Na}^+$ ,  $\text{Ca}^{2+}$ ,  $\text{Cu}^{2+}$ ,  $\text{Pb}^{2+}$ ,  $\text{Ag}^+$  and etc., user-defined method is supported.

## Conductivity

- 1-5 points calibration automatically recognizes the standard solutions.
- Settable parameters, including cell constant, reference temperature (5/10/15/18/20/25°C), temperature compensation coefficient and TDS factor.
- Temperature compensation type (none, linear, pure water).

## DO

- Support for air-saturated water or zero oxygen calibration.
- Auto barometric pressure compensation.
- Manual Salinity Factor Correction.
- Selectable pressure unit, including  $\text{kPa}$ ,  $\text{mbar}$ ,  $\text{Torr}$ ,  $\text{Atm}$ .

## 1.2 Technical Specification

Table 1-1 Instrument Specifications

Code		KZD001
pH/pX level		0.001 pH/pX
mV	Range	(-2000.00~ 2000.00) mV
	Resolution	0.01mV
	Accuracy	$\pm 0.03\%$ or $\pm 0.1\text{mV}$
	Repeatability	0.1mV
	Input Current	$\leq 1 \times 10^{-12}\text{A}$
	Input Impedance	$\geq 3 \times 10^{12}\Omega$
pH	Range	(-2.000~ 20.000) pH
	Resolution	0.001pH
	Accuracy	$\pm 0.002\text{pH}$
	Repeatability	0.001pH
	Measurement Accuracy	$\pm 0.01\text{pH}$
	Measurement Repeatability	0.005pH

	Code	KZD001
pX	Range	(-2.000~ 20.000) pX
	Resolution	0.001pX
	Accuracy	±0.002pX
	Repeatability	0.001pX
	Measurement Accuracy	±0.01 pX
	Measurement Repeatability	0.005pX
Ion concentration	Range	(1E-9~9.999E9), mol/L, mmol/L, g/L, mg/L, µg/L, ppm, ppb
	Resolution	4 significant digits
	Measurement Accuracy	±0.3%
Conductivity	Range	0.000 µS/cm~3000mS/cm
	Resolution	0.001µS/cm, automatic switching according to the range
	Accuracy	±0.5% (FS)
	Repeatability	0.17%(FS)
	Measurement Accuracy	±0.80% (FS)
	Measurement Repeatability	0.40% (FS)
Resistivity	Range	5.00Ω.cm~100.0MΩ.cm
	Resolution	0.01Ω.cm, automatic switching according to the range
	Accuracy	±0.5% (FS)
TDS	Range	0.000 mg/L~1000g/L
	Resolution	0.001mg/L, automatic switching according to the range
	Accuracy	±0.5% (FS)
Salinity	Range	(0,00~8,00)%
	Resolution	0,01%
	Accuracy	±0,1%
	Measurement Accuracy	±0,2%
Dissolved oxygen	Range	(0.00~99.99)ppm, (0.00~50.00) ppm (measuring range)
	Resolution	0,01 ppm

Code		KZD001
Dissolved oxygen	Accuracy	$\pm 0,10$ ppm
	Repeatability	0,15 ppm
	Accuracy at 0% DO	$\leq 0,1$ ppm
	Measurement Accuracy	$\leq 20,00$ ppm: $\pm 0,30$ ppm, $> 20,00$ ppm: $\pm 10,0\%$ .
	Response time	$\leq 45$ s (90% response at 20°C)
	Salinity Compensation	$\pm 2\%$
Saturation	Accuracy	(0,0~600,0)%
	Resolution	0,1%
	Accuracy	$\pm 2,0\%$
	Measurement Accuracy	$\pm 10,0\%$
Temperature	Range	(-10,0~ 135,0) °C/ (14,0~ 275,0) °F
	Resolution	0,1 °C/0,1 °F
	Accuracy	$\pm 0,1$ °C
	Instrument indication error	$\pm 0.3^\circ\text{C}$ (0°C~ 60°C), $\pm 1.0$ °C (Else)
Work environment		Ambient temperature: (0~ 40) °C Relative humidity: not more than 85%
Dimensions (L×B×H), weight (kg)		90mm × 255mm × 40mm, 0,5kg
Power supply		Rechargeable lithium battery, power adapter (Input AC 100~240V; Output DC 5V)

### 1.3 Function Introduction

Table 1-2 Functions Specification

Features		Explanation
Basic Function	Languages	English
	Backlight adjustment	■
	Automatic diagnostics	■
	Factory reset	■
	Default parameter	■

Features		Explanation
Basic Function	Prompt Sound	■
	Time settings	■
	Power failure protection	■
	Login password protection	■
	Firmware upgrade	■
	Anti-interference automatic recovery	■
	Automatic shutdown	■
	Protection	IP65
Reading Function	Reading stability settings	■
	Auto-lock reading	■
	End point judgment/reading mode	Continuous, Auto, Timed
	Sample ID	■
	Alarm	■
Data Management	Storage	1000 sets of measurement parameters each
	View	■
	Delete	■
	Alarm	■
	GLP	■
Communications and external devices	U Disk	■
	Content and format customization	Standard, GLP, Custom format
	Connect to the PC for data collection	■
	Connect to a PC for instrument control	■
	Wireless	Bluetooth
pH/mV Measurement	pH electrode status/performance	Slope, Electrode status (Excellent, good, bad)
	Multi-point calibration	8 points
	Automatic standard solutions recognition	6 groups
	Standards customization	■

Features		Explanation
pH/mV Measurement	Standard groups customization	1 group
	Temperature compensation	Automatic/Manual
	pH Electrode Diagnostics	■
	pH electrode calibration reminder	■
	pH electrodes mandatory calibration	■
	pH standard solution verification	■
	pH Mandatory Verification	■
	ORP Measurement	■
	Recordatorio de calibración del electrodo POR	■
	ORP electrode calibration reminder	■
pX/ISE Measurement	Built-in ions methods	12 kinds
	Ion's customization	■
	Multi-point calibration	6 points
	Optional units	mol/L, mmol/L, g/L, mg/L, μg/L, ppm, ppb
	Measurement mode	Direct reading method, Standard addition method, Sample addition method, GRAN method
	Ion electrode calibration reminder	■
	Ion electrode mandatory calibration	■
Conductivity Measurement	Conductivity	■
	Resistivity	■
	TDS	■
	Salinity	■
	Conductivity-ash	■
	Reference temperature	6 types, default 25.0°C
	Multipoint calibration	5 points
	Automatic standard solutions recognition	Universal Standard, GB Standard

Features		Explanation
Conductivity Measurement	Cell constant set	■
	Temperature compensation coefficient set	■
	Salinity compensation coefficient set	■
	Compensation mode	Non-compensatory, linear, pure water
	Automatic temperature compensation	■
	Manual temperature compensation	■
Dissolved oxygen Measurement	Measurement principle	Polarographic
	Zero calibration	■
	Air calibration	■
	Automatic temperature compensation	(0,0~45,0) °C
	Automatic atmospheric pressure compensation	(600~1100) mbar
	Manual atmospheric pressure compensation	(600~1100) mbar
	Atmospheric pressure units	kPa, mbar, Torr, Atm
	Manual salinity compensation	(0,0~50,0) g/L
Temperature Measurement	Temperature units	°C , °F
	Temperature calibration	■
	System & Running log	■
	User management	■
	Sample list	■

■ Equipped

## 2 SAFETY NOTICES

Please read the manual before use. The user **MUST** use the instrument following this manual to avoid damage to the user and equipment.

Before using the meter, **READ** the following notes:

- **DO NOT DISASSEMBLE** the device for inspection or repair.
- To prevent electric shock or damage to the device, **DO NOT** place cables and connectors in any liquid, wet or corrosive environment.
- Please use the defaulted power adapter, **DO NOT** use it if the power cord is damaged (the wire is exposed or broken).
- **DO NOT** use in flammable and explosive environments.
- **DO NOT** use if the user finds any abnormalities such as damage or deformation of the device.

The following identifier will be used in this manual.



### TIPS

Tips help users use the meter.

## 3 TERMS EXPLANATION

### pH/pX

- **pH/pX Slope:** The amount of potential change generated by each 1 pH/pX change, expressed in mV/pH or by 100% Theoretical Slope (PTS).  $pX = -\log[X]$ , where  $[X]$  means molar concentration (mol/L) of X ions.
- **EO of pH:** Also known as “zero potential”, it usually refers to the potential value at a pH of 7.
- **One-point calibration:** Calibration with a standard solution.
- **Two-point calibration:** Calibration with two standard solutions.
- **Multi-point calibration:** Calibration with more than two standard solutions.

### Redox potential (ORP).

- **Redox potential:** Also known as ORP value, it refers to the potential difference between the potential difference of a measuring battery relative to a standard hydrogen electrode consisting of an indicator electrode, a reference electrode, and a solution under test. The symbol for ORP measurement is “RmV”, and the unit is mV.
- **One-point calibration:** Calibration with an ORP standard solution.
- **Offset:** =  $ERmV - E$  (ERmV potential relative to the hydrogen electrode, E measured potential). At a certain temperature, when the ORP calibration solution is used for calibration, the potential value “RmV” and the potential difference between the measured system.

### Electrical conductivity

- **Cell Constant:** Also known as the conductivity cell constant. The ratio of the distance to the area of the electrode sheet, expressed in  $cm^{-1}$ . Usually, there are conductance electrodes with several cell constants such as 0.01, 0.1, 1.0, 10, etc. The conductance electrode with a cell constant of 1.0 is the most used one and has a wide measurement range.
- **Temperature Coefficient:** The change in conductivity caused by a 1°C change in temperature is usually expressed in  $\%/^{\circ}C$ , and the default is 0.02, which is 2.00 $\%/^{\circ}C$ .
- **TDS Conversion Factor:** The conversion factor between conductivity and TDS, which defaults to 0.5.

## Dissolved oxygen

■ **Dissolved oxygen concentration:** The content of oxygen dissolved in water. Expressed in milligrams of oxygen per liter of water, usually denoted as DO.

■ **Dissolved Oxygen Saturation:** The ratio of the on-site dissolved oxygen concentration to the saturated dissolved oxygen concentration under the same conditions.

■ **Salinity:** Salt content in water, expressed in g/L. When the salinity increases by 1g/L at 15°C, the saturated dissolved oxygen of water decreases by about 0.0559 mg/L.

■ **Zero-point calibration:** Electrodes are calibrated in “oxygen-free water” (freshly formulated 5% sodium sulfite solution).

■ **Fullness calibration:** The electrodes are calibrated in air or water fully dissolved and saturated with air.

■ **Atmospheric pressure compensation:** The atmospheric pressure affects the measurement of dissolved oxygen concentration and dissolved oxygen saturation, and atmospheric pressure compensation is required. Before calibration, the on-site atmospheric pressure needs to be input, expressed in mbar, and the default is 1013 mbar.

## General

■ **Calibration reminder (recommended):** “Electrode calibration” prompts on the homepage, user can start measurement without last calibration.

■ **Calibration reminder (mandatory):** “Electrode calibration” prompts on the homepage, calibration is required for accurate measurement.

■ **Upper limit:** The upper limit value is monitored for the measured or calibrated data, and the upper limit value must not be lower than the lower limit value.

■ **Lower limit:** Lower limit monitoring of measured or calibrated data.

## 4 OVERVIEW AND INSTALLATION

### 4.1 Overview

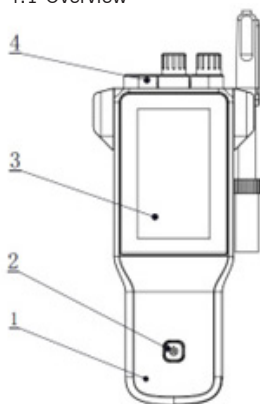

- 1 Meter Body
- 2 Power Key
- 3 Display
- 4 Socket Cap

Figure 4-1 Front view

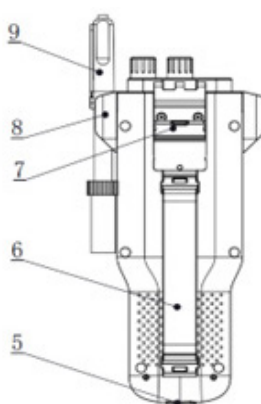

- 5 Power sockets
- 6 Wristbands
- 7 Flip Tilting Stand
- 8 Electrode Holder
- 9 Electrodes

Figure 4-2 Back view

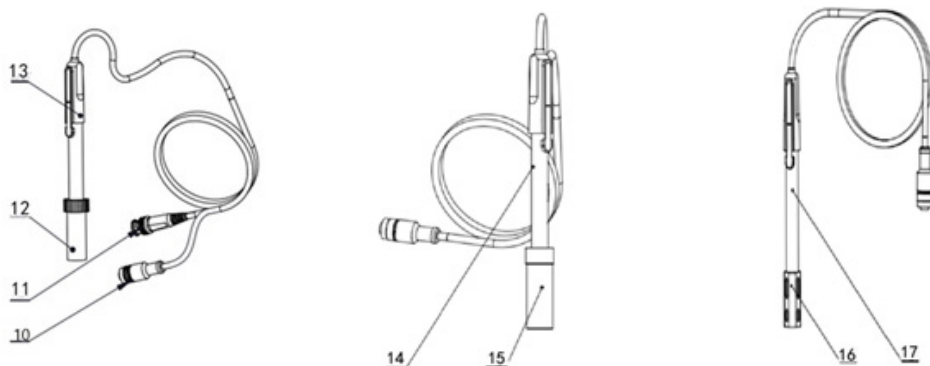

- 10 Four-pin aviation connector
- 11 pH electrode connector
- 12 Electrode protection cap
- 13 pH electrode
- 14 Conductivity electrode
- 15 Conductivity electrode protection cap
- 16 Dissolved oxygen electrode protection cap
- 17 Dissolved oxygen electrode

Figure 4-3 Electrodes and connectors

Table 4-1 Connector Specifications

Electrode type	Connector specifications	Electrodes Connection
pH electrode	BNC(Q9)	pH electrode, ORP electrode, ISE probe
DO/T electrode	Four-pin aviation	DO electrode, ATC probe
Conductivity electrode	Five-pin aviation	Conductivity electrode

## 4.2 Instrument Installation

### 4.2.1 Electrodes Stand Installation



- 1 Screw
- 2 Hold part
- 3 Electrode stand base
- 4 Fixing holes

#### Installation:

- 1) Pull the wristband switch at the head of the wrist so that its closed round hole opens.
- 2) Snap the opened round hole card slot into the shaft of the corresponding instrument housing and close the round hole.
- 3) The lower wristband card slot is also operated as above.

Figure 4-4 Electrode stand installation

### 4.2.2 Electrodes Connection

#### ■ Connection of pH electrodes

Push the pH Electrode into the electrode holder. Remove the socket protector cap of the pH electrode. Connect the pH electrode into the right socket. If the ATC probe is applied, or ATC has been integrated into the pH probe, please connect the ATC probe onto the DO/T electrode socket.

#### ■ Connection of conductivity electrodes

Push the conductivity electrode into the electrode holder. Remove the protector cap of the conductivity electrode. Connect the conductivity electrode into the right socket. Combination conductivity probes integrated with ATC probe. If the separate ATC probe is applied, please connect the ATC probe onto the DO/T electrode socket. At the measurement, please choose the right input of ATC in the meter when you applied a separated ATC probe.

#### ■ Connection of dissolved oxygen electrodes

Push the dissolved oxygen electrode into the electrode holder. Remove the protector cap of the dissolved oxygen electrode socket. Connect the dissolved oxygen electrode into the right socket. All dissolved oxygen electrodes integrated with ATC probe.



#### TIPS

- The instrument adopted DO Electrode with a four-pin aviation connector.
- The ATC module of the DO electrode as temperature info input also works for pH measurement. As well the ATC of the connector of pH combination is not available at this period.

## 5 INSTRUMENT OPERATION

### 5.1 Switch On/Off

Press and release  to switch on the meter. The startup screen shows software version and other related information. After the self-test program, the screen turns to the homepage and the meter are ready to measure. If the meter does not turn on, charge the meter for 15 minutes. Otherwise, please contact the manufacturer for further assistance.

Press and hold the key  for more than 3 seconds and release to shut down.

### 5.2 Screen Icons

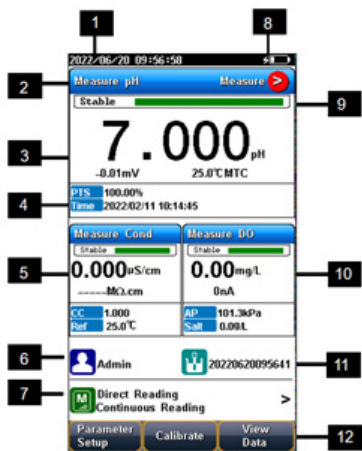







- 1 System time.
- 2 Measurement parameters.
- 3 Main measurement box.
- 4 Calibration information.
- 5 Measurement box.
- 6 User ID.
- 7 Method management.
- 8 Power information.
- 9 Reading states.
- 10 Measurement box.
- 11 Sample ID.
- 12 Function buttons.

Figure 5-1 Screen icons explanation

The instrument displays symbol identification that has the following functional implications:

Table 5-1 Symbol Explanation

No.	Symbol	Explanation
1		Reading status, display the measurement status of reading, stable, locked, each indicates that the processing, stable, and reading completed.
2	PTS	The percentage slope of the pH electrode calibration data
3	BUFF	The Standard buffer solution for calibration

No.	Symbol	Explanation
4	Auto Mode	Auto-recognition of Standards
5	Manual Mode	Manual - recognition of Standards
6	No.	Number
7	ATC	Automatic temperature compensation
8	MTC	Manual temperature compensation
9	E	Measured potential in mV
10	RmV	The relative potential value in mV
11	Offset	Offset potential, in mV
12	Temp	Temperature in °C and F
13	Res	Resistivity in $\Omega \cdot \text{cm}$ , $\text{k}\Omega \cdot \text{cm}$ , $\text{M}\Omega \cdot \text{cm}$
14	Cond	Conductivity in $\mu\text{S}/\text{cm}$ , $\text{mS}/\text{cm}$
15	Zero Point	Dissolved Oxygen Zero calibration
16	Full Scale	Dissolved Oxygen Air calibration
17		Measurement method management, display the current method information
18		Standard solution for pH calibration
19		Standard solution for ion calibration
20		Standard solution for conductivity calibration
21		User ID
22		Sample ID

### 5.3 Methods Management

The meter provides a library of built-in methods. Select the proper method to measure, system loads method's preset information, including the method name, brief overview, creator, creation date, and measurement parameters.

In the method settings, it supports the navigation setting including the method information, parameters, reading mode, pX parameters setting, pH parameters setting, ORP parameters setting, EC parameters setting, DO parameters setting, temperature setting and data management setting. For the first use, please follow the guide to settings the measurement parameters.



Figure 5-2 Methods Information



#### TIPS

If a modified built-in method is not saved to library, the “Method management” logo will turn to red. When the user returns to the method management page, the system will prompt.

#### 5.3.1 Update Method

When the method is revised by the setting, there is a red mark in the method management logo to remind user that the current method is different from the method in the library.

When press the method in the method library, there is a system tip to give user a choose to update or create a new method.

### 5.3.2 Create a new Method

There are three modes to create a new method: create method step by step in the system, save the setting as a new method in the system, and save the method with a new name, description and location. The location can be the system and U disk.

Figure 5-3 Method setting view



### 5.3.3 Delete a Method

There are 16 methods saved in the meter as the default setting in the library method. The No.001-No.016 method cannot be deleted, and the others can be deleted.

### 5.3.4 Save and Load a Method

It is support to store up to 50 methods in the meter, and save and load the methods in the U Disk.

## 5.4 Parameter Setting

In the measuring, users can set the instrument parameters by pressing "Parameter Setting" to set the measuring parameters including tutorial setting, basic method information, select parameters, endpoint format, pH parameter, pX/ISE parameter, ORP parameter, EC parameters setting, DO parameters setting, temperature parameter, data management, output setting, user management, system setting and GMP mode manage.

Figure 5-4 Parameter settings of instrument

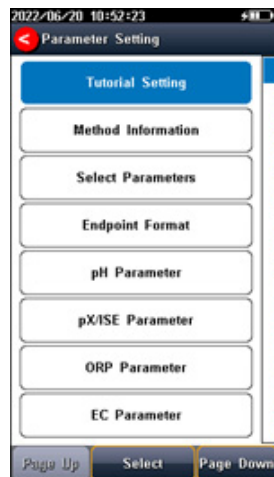

### 5.4.1 Tutorial setting

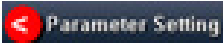
For the first use, please follow the guide to settings the measurement parameters. After all the settings, press the “” to return to the previous page.

### 5.4.2 Method basic information

The meter provides a library of built-in methods. Select the proper method to measure, system loads method's preset information, including the method name, brief overview, creator, creation date, and measurement parameters.

### 5.4.3 Select parameters

It could select one measurement parameter from pH, pX, Ion Conc and ORP, resistivity, conductivity, TDS, salinity, ash, DO, saturation every test.

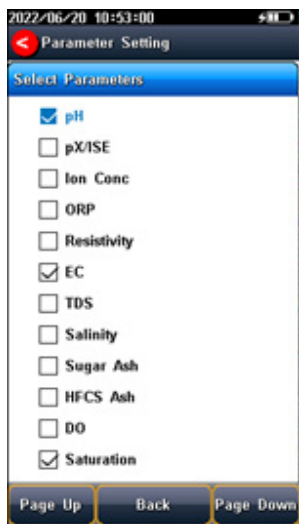

The instrument contains up to 3 measurement modules, and each measurement function can select different measurement parameters (switch the parameters by clicking on the blank area of measurement box of screen).

Select the proper measurement parameters to perform a measurement. The screen displays the detail of three measurement parameters when three modules are chosen. Two parameters are shown as two modules are chosen. Single parameter is shown by one measurement method is selected.

Figure 5-5 Select parameters

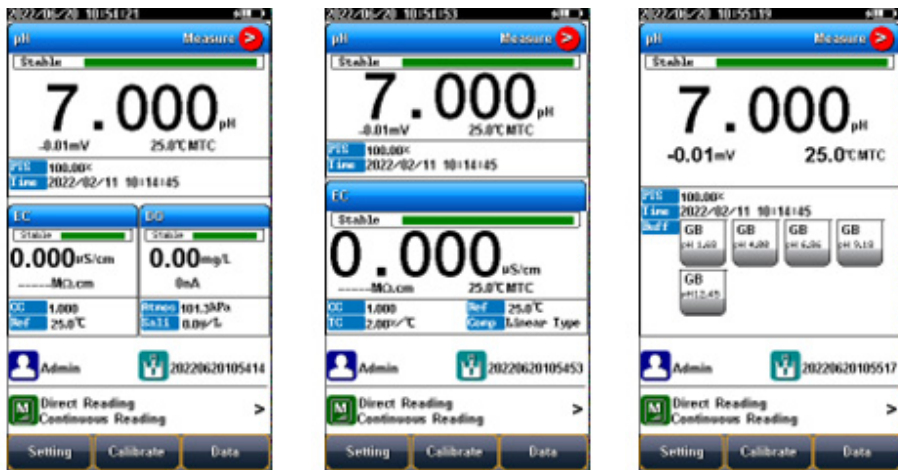

Figure 5-6 Measurement parameters

#### 5.4.4 Reading Mode Settings

The meter provides three reading modes, including continuous reading, auto reading, and timed reading.

- Continuous reading: The instrument displays real-time measurement results. User can end the measurement at any time and save the last result.
- Auto-reading: The measurement reached the balance, and the meter locked the reading result. The meter offers “Fast”, “Medium”, “Strict” and “Custom”, four options for endpoint detection conditions.
- Timed reading method: Timed Reading contains two kinds of timed reading methods: “Interval Measurement” and “Timed Measurement”. “Interval Measurement” provide measurement results at interval time and “Timed Measurement” provide measurement result after a set time.

Table 5-2 Reading Parameters Settings

Stability Type		pH	pX/ Ion concentration	Conductivity	DO
Fast	Stable time	4s	4s	5s	5s
	Fluctuation	0,6mV	0,3mV	1,0%	4nA
Medium	Stable time	6s	8s	8s	8s
	Fluctuation	0,1mV	0,08mV	0,4%	3nA
Strict	Stable time	8s	12s	15s	15s
	Fluctuation	0,03mV	0,03mV	0,1%	2nA
Custom (Recommended value)	Stable time	1 to 30s	1 to 30s	1 to 30s	1 to 30s
	Fluctuation	0,03~1mV	0,03~1mV	0,1~2%	2~5nA

## 5.4.5 pH parameter setting

### ■ pH electrode information

In the meter setting, a set of pH Electrode info is defaulted. At the measurement, the meter loads the defaulted pH electrode's info including serial number, last calibration result, including the number of calibration points, slope value, zero-point potential value and electrode state description, etc., the calibration time and calibrator will also be loaded together.

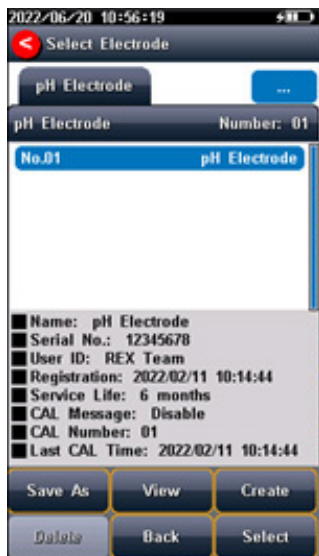

Figure 5-7 pH electrode information

### ■ Recognition

Auto Mode and Manual Mode.

In some special cases, it is necessary to use some non-standard pH buffer solutions, or use two very close pH standard buffer solutions for electrode calibration. In this case, the manual standard solution identification function can be used. When set to "Manual Mode", the pH value of the current standard solution can be input during and used for electrode calibration.

### ■ pH Buffer groups

The meter provides various Standards Group including GB, DIN, NIST, USA, MERK and JIS. And allows the user to prepare the customized Standard groups.

Table 5-3 Standard Solution Groups

Groups	Contents
GB	1,680pH, 3,559pH, 4,003pH, 6,864pH, 7,409pH, 9,182pH, 12,460pH
DIN	1,680pH, 2,000pH, 3,557pH, 3,775pH, 4,008pH, 6,865pH, 7,000pH, 7,416pH, 9,184pH, 10,014pH, 12,454pH
NIST	1,677pH, 4,008pH, 6,864pH, 7,000pH, 7,416pH, 10,014pH, 12,469pH
EE.UU.	1,680pH, 4,010pH, 7,000pH, 10,010pH
MERK	2,000pH, 4,000pH, 7,000pH, 9,000pH, 12,000pH
JIS	1,680pH, 4,008pH, 6,865pH, 7,413pH, 9,180pH, 10,010pH

Usually, we use the pH value corresponding to 25.0°C to mark the pH standard buffer solution, such as NIST 7.00pH standard solution, which means the standard pH buffer solution 7.00pH, and it is 7.00pH at 25.0°C.

After selecting the standard solution group, we need to select the standard buffer solution used for calibration from the standard solution group. The instrument supports up to 6-point calibration, that is, up to 6 standard solutions can be selected. Since the pH values of multiple standard buffer solutions in the standard solution group may be very close, to ensure that the instrument can correctly identify the standard buffer solution, will limit the selection of standard solutions with neighboring pH values. The check mark indicates the currently used standard solution group and the corresponding standard solution.

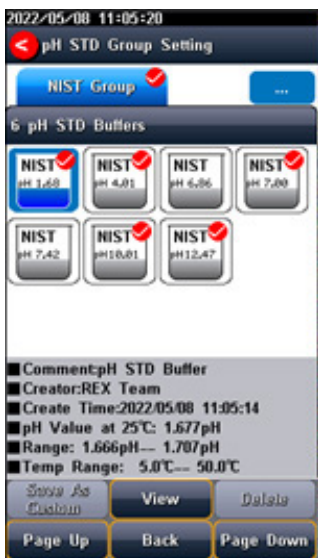
**TIPS**

If the selected standard solution group is different from the pH standard buffer solution used, it will lead to wrong calibration results.

Figure 5-8 Selection of standard groups and standard solutions

## ■ Resolution settings

The pH measurement resolution of the instrument is adjustable.

pH resolution: 0.001pH, 0.01pH and 0.1pH.

mV resolution: 0.01mV, 0.1 mV and 1 mV.

Set the result resolution through “pH Parameters” - “Resolution”.

## ■ pH Alarm setting

The meter support pH measurement and calibration result monitoring alarm. The setting includes slope limit, potential value limit and monitoring options. When the measurement results out of the selected range, the meter alarms.

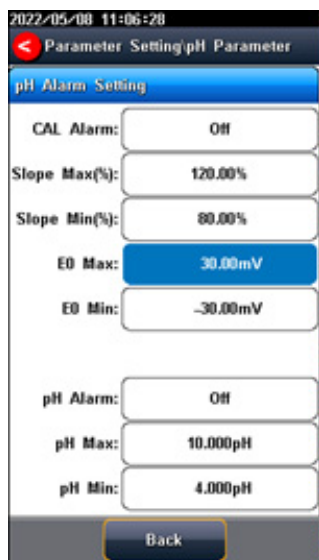

Figure 5-9 pH Alarm setting information

## ■ pH Calibrate reminder settings

The meter provides calibration prompts function. From the setting, the user can select calibration reminder (recommended) and calibration reminder (mandatory) for future calibration.

Calibration reminder (recommended): When enable the calibration reminder, the instrument verifies whether the calibration data of pH electrode is within the validity period. If calibration information expires, a striking calibration reminder will appear at “Calibrate” on the main interface, but it will not affect the measurement and data saved.

Calibration reminder (mandatory): When enable the mandatory calibration, the instrument verifies whether the calibration data of pH electrode is within the validity period. If calibration information expires, a striking calibration reminder will appear at “Calibrate” on the main interface, the measurement data cannot be saved and output.

Figure 5-10 pH calibration reminder setting information

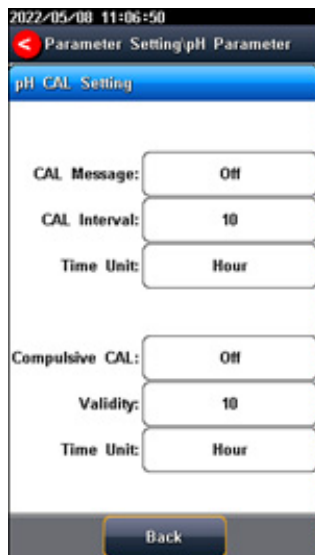

#### 5.4.6 pX/ISE parameter settings

##### ■ pX electrode information

The instrument has one pX electrode created by default, which is convenient for users. When using the built-in default electrode, the instrument automatically loads the electrode serial number and the last calibration result, including calibration points, slope value, zero-point potential value, etc., and the calibration time and calibrator are also loaded.

##### ■ Ion mode

Ion mode corresponds to pX/ISE, ion concentration measurement. The instrument supports conventional ion modes and user-defined ion modes. The instrument provides a variety of commonly used ion modes such as: F<sup>-</sup>, Cl<sup>-</sup>, Br<sup>-</sup>, I<sup>-</sup>, NO<sub>3</sub><sup>-</sup>, BF<sub>4</sub><sup>-</sup>, NH<sub>4</sub><sup>+</sup>, K<sup>+</sup>, Na<sup>+</sup>, Ca<sup>2+</sup>, Cu<sup>2+</sup>, Pb<sup>2+</sup>, Ag<sup>+</sup> and etc., which are convenient for use. Users can directly measure the concentration of the corresponding ions as long as they are equipped with the corresponding ion selective electrode.

Custom ion mode: Press the “Custom” key, enter the ion name (maximum 8 characters), then enter the molecular weight (molar mass), and select the ionic valency.



Figure 5-11 Ion mode management

## ■ Select measurement mode

The instrument supports 4 ion measurement modes: direct reading concentration method, standard addition method, sample addition method, GRAN Measurement method.

Users can choose the following ion measurement methods according to their requirements. In general, when the ion measurement parameter selects pX or ion concentration measurement, it is recommended to use the direct reading concentration method for measurement, which has a fast measurement speed and is suitable for the measurement of batch samples. STD addition, sample addition and GRAN measurements are only valid when the measurement parameter selects ion concentration.

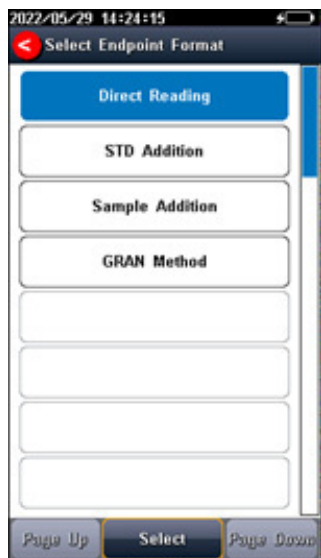

Figure 5-12 Ion measurement mode selection

**Direct reading concentration method:** also called standard curve method, is the most commonly used method for measuring ion concentration. According to the Illuminant formula, a linear relationship is established between the ion concentration and the electrode potential, so as to determine the ion concentration of the sample.

**STD addition method:** Also called the known addition method, it is mainly used to measure samples with low content. The standard solution is added to the sample, and the concentration value of the sample is determined by measuring the potential change before and after the addition.

**Sample addition method:** Similar to the standard addition method, it is mainly used to measure samples with higher content. The sample to be tested is added to the standard solution, and the concentration value of the sample is determined by measuring the potential change before and after the addition.

**GRAN measurement method:** similar to the standard addition method, it is mainly used to measure samples with low content, and the concentration value of the sample is measured according to the mathematical principle of the GRAN mode.

Users can choose according to actual requirements.

**TIPS**

- When selecting “pX” measurement parameter, the measurement mode is only valid for the direct reading concentration method.
- Due to the particularity of the standard addition, sample addition and GRAN measurement method, it can only be used in single channel mode.

### ■ Resolution settings

The pX measurement resolution of the instrument is adjustable.

pX resolution: 0.001pX, 0.01pX and 0.1pX.

mV resolution: 0.01mV, 0.1 mV and 1 mV.

Set the result resolution through “pX/ISE parameter” - “Set Resolution”.

### ■ pX/ISE Alarm setting

The meter support pX/ISE measurement alarm. When the measurement results out of the selected range, the meter alarms.

Enter the ion alarm limit setting through “pX/ISE parameter” - “Alarm setting”, and you can set the max and min limit values of ion concentration measurement.

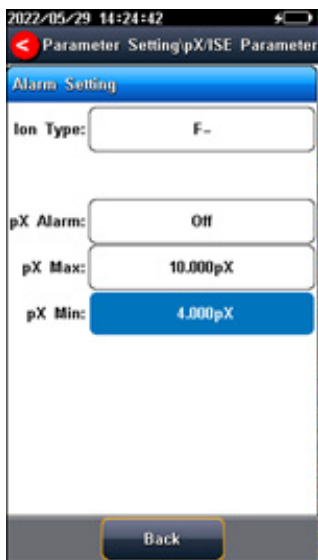

Figure 5-13 pX/ISE Alarm setting information

## ■ pX calibration reminder settings

The meter provides calibration prompts function. From the setting, the user can select calibration reminder (recommended) and calibration reminder (mandatory) for future calibration.

Calibration reminder (recommended): When enable the calibration reminder, the instrument verifies whether the calibration data of electrode is within the validity period. If calibration information expires, a striking calibration reminder will appear at “Calibrate” on the main interface, but it will not affect the measurement and data saved.

Calibration reminder (mandatory): When enable the mandatory calibration, the instrument verifies whether the calibration data of electrode is within the validity period. If calibration information expires, a striking calibration reminder will appear at “Calibrate” on the main interface, the measurement data cannot be saved and output.

Under “pX/ISE parameter” - “Calibrate Reminder”, set calibration reminder and mandatory calibration. Fulfill the electrode calibration reminder function by setting the calibration period and time, and the electrode calibration function by setting the mandatory calibration validity period and time.

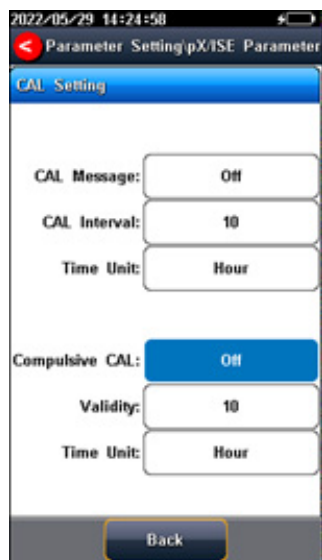

Figure 5-14 pX calibration reminder setting information

### 5.4.7 ORP Parameter Settings

#### ■ ORP electrode information

In the meter setting, a set of ORP Electrode info is defaulted. At the measurement, the meter loads the defaulted electrode's info including serial number, resolution (mV supports 0.01mV, 0.1 mV and 1mV settings), recognition mode and last calibration result (nominal and offset), the calibration time and calibrator are also loaded.

## ■ ORP Alarm setting

The meter supports ORP measurement and calibration result monitoring alarm. When the measurement results out of the selected range, the meter alarms.

Enter the ORP alarm limit setting through “ORP parameter” - “Alarm Setting”, and you can set the max and min limit values of ORP measurement.

## ■ ORP calibration reminder setting

ORP electrode calibration reminder: If the ORP electrode is not calibrated after the calibration period, the instrument will display a prominent calibration reminder at the “Calibrate” on the initial interface, but it does not affect the use.

ORP electrode mandatory calibration: After turning on, the instrument verifies whether the ORP electrode calibration data is within the validity period. If the calibration information expires, only the test results can be read before normal calibration, and the data cannot be saved and output.

Under “ORP parameter”-”Calibrate Reminder”, set the calibration reminder and mandatory calibration settings. Fulfill the electrode calibration reminder function by setting the calibration period and time, and the electrode calibration function by setting the mandatory calibration validity period and time.

### 5.4.8 EC Parameter Settings

#### ■ EC Electrode management

The electrode information includes the name, serial No., user ID, registration time, service life, calibration message, calibration number, last calibration time. It allows user to choose one electrode to calibrate and measure samples.

The meter has one created default electrode, which is convenient for users. When using the built-in default electrode, the meter automatically loads the electrode serial number and the last calibration result, including calibration points, slope value, zero-point potential value, etc., and the calibration time and calibrator will also be loaded.

2022/05/08 10:30:41

Parameter Setting EC Parameter

EC Electrode

Name: EC Electrode

Serial No.: 12345678

Electrode Type: Cell Const 1

CAL Type: CAL By Standards

CAL Result:

No.	STD Value	Measured	Cell Const
5101	145305/cm	140005/cm	1.004

Time: 2022/05/08 10:30:05

User ID: Admin

Back

Figure 5-15 EC electrode information

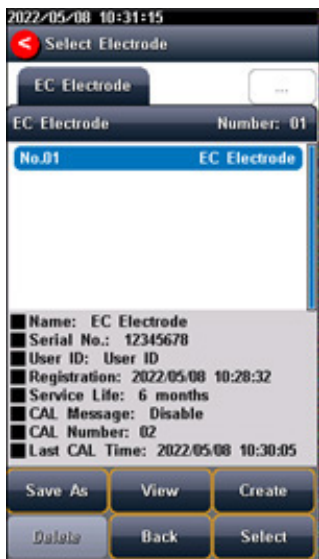

The meter allows users to create and save electrodes information up to 5. The electrode information contains electrode name, electrode serial number, electrode type, registrant, registration time, shelf life, shelf-life reminder, calibration No., latest calibration time etc.

Figure 5-16 Electrode management

### ■ Conductivity electrode type

Conductivity electrode: Four conductivity cell constant 0.01, 0.1, 1, 10. The defaulted conductivity cell constant is 1. Users need to enter the cell constant value on the label of conductivity electrode for accurate measurement.

### ■ EC calibration type

EC calibration type: Calibration by standards and input manually.

Cal By Standards: Cell constant is calibrated with standard conductivity standard solution.

Input manually: It allows user to set the cell constant.

### ■ Calibration information

The meter provides two EC standards groups including universal group and GB group. And allows the user to prepare the customized standard groups.

For local standards, please choose the customization to perform calibration.

Table 5-5 Standard solution groups

Standard group	Standard solution
Universal Group	10 $\mu$ S/cm, 84 $\mu$ S/cm, 500 $\mu$ S/cm, 1413 $\mu$ S/cm and 12880 $\mu$ S/cm.
GB group	146.5 $\mu$ S/cm, 1408 $\mu$ S/cm, 12852 $\mu$ S/cm and 111310 $\mu$ S/cm.

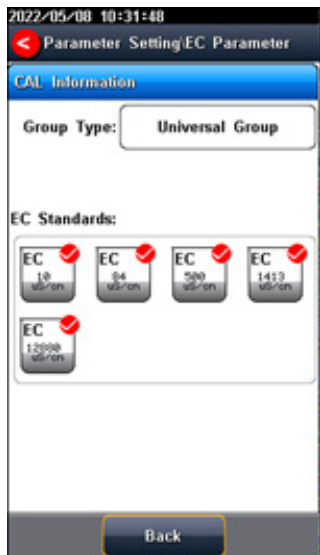

Figure 5-17 Selection of conductivity standards

### ■ EC Reference temperature

Conductivity reference temperature: The conductivity of the solution is greatly affected by temperature, to make the conductivity measurement results at different temperatures comparable, the conductivity and temperature values at the time of measurement are usually recorded and converted into the conductivity value at a certain temperature through temperature compensation, which is the reference temperature.

When measurement parameter is conductivity, TDS or resistivity, the meter allows settings of 5.0°C, 10.0°C, 15.0°C, 18.0°C, 20.0°C, 25.0°C, 6 reference temperatures, the default reference temperature is 25°C.

When measurement parameter is salinity, the default reference temperature is 18 °C and cannot change.

When measurement parameter is conductivity ash, the default reference temperature is 20 °C and cannot change.

### ■ Conductivity Compensation

EC Compensation Mode: Three different compensation modes can be used for various applications. The meter supports Linear type, DI water type and non-comp type.

1) Linear type: Linear compensation is usually used for the measurement of medium and high conductivity solutions. With linear compensation, you can set the temperature compensation coefficient, which defaults to 2.00%/°C (approximately the temperature compensation coefficient of a sodium chloride solution at 25°C). It allows user to set the temperature coefficient.

2) DI water type: DI water compensation is usually used for the measurement of pure water and ultrapure hydropower conductivity below 5μS/cm. It allows user to set the temperature coefficient.

3) Non-comp type: Non compensation is usually used to obtain the true conductivity value at the measured temperature.

### ■ TDS Parameter

The TDSF calibration type can be calibrated by standard solution or setting the TDS factor. The TDS factor can be adjustable, and the default is 0.500. It allows user to calibrate the TDS factor.

### ■ Salinity parameter

The meter supports both default salinity and seawater salinity measurement types.

Sea salinity mode: it indicates the nominal salinity value used to measure seawater salinity correction. The standard seawater salinity concentration adopted here is 3.500%, also written as 35 psu. Default Salinity Mode: the salinity of common sample, which can be used to approximate the salinity of the measured solution.

### ■ Conductivity Ash parameter

The meter supports the measurement of conductivity ash generally calculating the ash content using an ash conversion coefficient.

Ash Conversion Factor: Represents the conversion coefficient K of the conductivity of the solution to ash, which has a small value of  $10^{-4}$ .

Blank Conductivity: It allows to input manually or measure in the blank.

### ■ Alarm setting

The meter support measurement and calibration result monitoring alarm. The parameter includes the conductivity, TDS, salinity, resistivity, sugar ash and HFCS Ash.

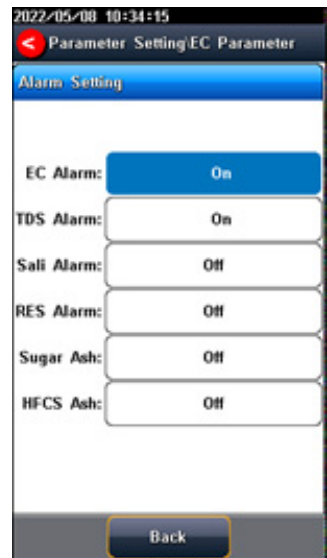

Figure 5-18 Alarm setting information

### ■ Calibration reminder settings

The meter provides calibration prompts function. From the setting, the user can select calibration reminder (recommended) and calibration reminder (mandatory) for future calibration.

Calibration reminder (recommended): When enable the calibration reminder, the instrument verifies whether the calibration data of conductivity electrode is within the validity period. If calibration information expires, a striking calibration reminder will appear at “Calibrate” on the main interface, but it will not affect the measurement and data saved.

Calibration reminder (mandatory): When enable the mandatory calibration, the instrument verifies whether the calibration data of conductivity electrode is within the validity period. If calibration information expires, a striking calibration reminder will appear at “Calibrate” on the main interface, the measurement data cannot be saved and output.

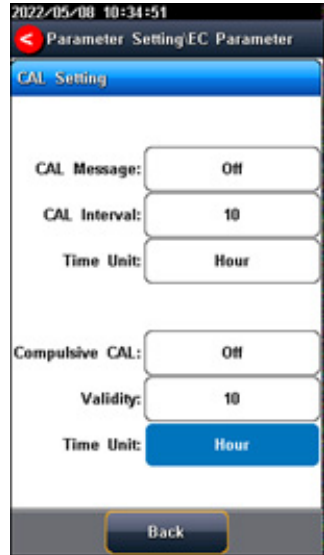

Figure 5-19 Calibration reminder setting information

## 5.4.9 Dissolved Oxygen Parameter Settings

### ■ DO electrode information

In the meter setting, a set of DO Electrode info is defaulted. At the measurement, the meter loads the defaulted DO electrode's info including serial number, last calibration result.



Figure 5-20 DO electrode information

### ■ DO salinity compensation settings

Salinity, is the amount of sodium chloride dissolved in 1 L of water, in g/L. The dissolved oxygen concentration of water is highly affected by salinity. Typically, for every 1 g/L increase in salinity, the saturated dissolved oxygen of water decreases by 0.0559 ppm.

Users can set salinity compensation on the setting page. The salinity compensation range of measurement is (0.0~50.0) g/L.



#### TIPS

If the sample has high salinity, salinity compensation is required to obtain accurate results.

### ■ DO barometric compensation

Atmospheric pressure is an important factor for dissolved oxygen concentration and dissolved oxygen saturation measurement. The meter supports automatic barometric compensation and manual barometric compensation modes in range of (600~1100) mbar. The default atmospheric pressure is 1013mbar in manual compensation mode.

Users can select the necessary compensation mode and pressure unit for measurement in the setting.



#### TIPS

Barometric compensation is important for measurement results in low atmospheric pressure areas.

### ■ Alarm setting

The meter support DO measurement and calibration result monitoring alarm. When the measurement results out of the selected range, the meter alarms.

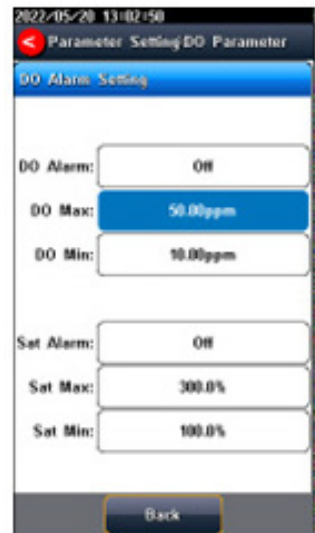

Figure 5-21 Alarm setting information

### ■ Calibration reminder settings

The meter provides calibration prompts function. From the setting, the user can select calibration reminder (recommended) and calibration reminder (mandatory) for future calibration.

**Calibration reminder (recommended):** When enable the calibration reminder, the instrument verifies whether the calibration data of DO electrode is within the validity period. If calibration information expires, a striking calibration reminder will appear at “Calibrate” key on the main interface, but it will not affect the measurement and data saved.

**Calibration reminder (mandatory):** When enable the mandatory calibration, the instrument verifies whether the calibration data of DO electrode is within the validity period. If calibration information expires, a striking calibration reminder will appear at “Calibrate” key on the main interface, the measurement data cannot be saved and output.

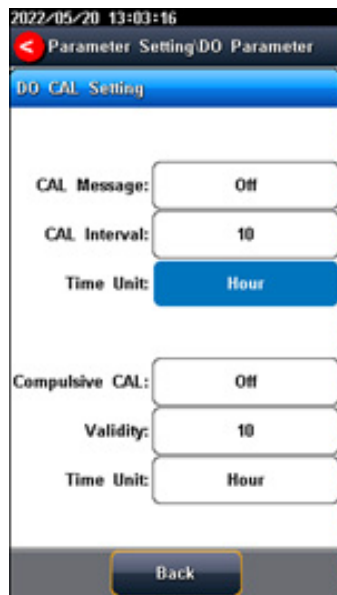

Figure 5-22 Calibration reminder setting information

#### 5.4.10 Temperature Parameter Settings

The temperature unit of the meter is selectable in °C and °F.

Temperature compensation mode: ATC and MTC.

ATC means automatic compensation. MTC means manual compensation. It allows user to input the temperature.

#### 5.4.11 Data Management Settings

### ■ Sample ID type

The instrument supports three setting methods of Sample ID: number order, time order, and manual.

- Number order: The sample ID No. is increasing with series number.

- Time order: The sample ID No. is increasing with sample measuring time. Format: Year/Y, Month/M, Day/D, Hour/H, Minutes/M, Second/S

- Manual: Manually set the sample ID No. It allows samples to manually enter the sample ID when saving or printing data.

### ■ Autosave setting

When this function is enabled, the meter saves the results when the reading is stable in the auto-reading and interval timed reading mode.

## ■ Data Overwrite

The meter provides 1000 sets of measurement results storage space. When this function is enabled, the results data that exceeds capacity will overwrite the old results data.

### 5.4.12 Output option

Output to: Printer or U flash driver.

Output content and format: The number of characters per line and the title name can be set. The data formats are GLP, STD, and custom.

### 5.4.13 User management

The instrument supports user management and can be divided into system administrators, method administrators, and operators. The instrument supports up to 8 users and password management, the first user defaults to the system administrator Admin. System administrators can add users, method administrators and set the permission.

### 5.4.14 System Parameter Settings

#### ■ System Date & Time

Settings of system date and time.

#### ■ Buzzer setting

Users can set the key sound by this setting.

#### ■ Brightness setting

Users can adjust the screen brightness by this setting.

#### ■ Auto Power off

The meter provides auto shutdown function. When the meter is not using, the meter switches off automatically.

#### ■ Bluetooth settings

The instrument supports Bluetooth function.

#### ■ Restore Default

The meter supports "Restore Default" and "Restore Parameters". "Restoring Default" will restore all meter parameters to the factory state. "Restoring parameters" will restore the measurement parameters to the factory state.

#### ■ Software version

Users can find the software version information on the general setting page.

## 5.5 pH Measurement

### 5.5.1 Calibration Preparation

The electrode slope and zero potential of pH electrodes drift slightly over time. To accurately measure pH, it is recommended to calibrate the pH electrode before use, the instrument supports 1-6 points calibration.

One point calibration is a calibration process with a single standard solution, commonly applied in a quick test. The calibration slope is 100% in here.

Two-point calibration is to use two pH standard buffer solutions to calibrate the electrode, and construct a linear calibration curve through two points. Two-point calibration is the most commonly used calibration method, and it is usually recommended that the pH value of the solution to be measured lies between the two standard buffer solutions. Two-point calibration can improve pH measurement accuracy.

Multi-point calibration is a calibration process with more than one standard solution. It is recommended to calibrate between two standard buffer solutions at the pH of the solution to be tested. Multi-point calibration covers a wider measurement range for accurate pH measurement. Before starting calibration, please prepare one or more pH standard buffer solutions.

### 5.5.2 Standards group selection

Before starting calibration, please prepare one or more pH standard buffer solutions. The meter has standards recognition function. Please set the Standard Group before the measurement.

You can also set the identification mode to "Manual Mode" and manually enter the nominal value during the calibration process.

### 5.5.3 pH Calibration

The calibration process is as follows:

1. Select a method. The method includes the parameter (e.g., pH), NIST standard solution group, pH 4.01, pH 7.00 and pH 10.01, auto Mode recognition.
2. Connect the ATC probe or enter the temperature manually.
3. Press the "Calibrate" -> "pH Calibration".
4. Put the cleaned electrode into pH 4.01 standard solution.
5. Wait for the instrument to display "Auto Mode Matched".
6. When the pH and temperature reading are stable, press the "Start".
7. If only 1-point calibration is required, after 1-point calibration is completed, press the "End" key to complete the calibration.
8. If multi-point calibration is required, please replace the pH7.00 and pH10.01 standard buffer solutions. After cleaning the electrode, put the electrode into the standard solution. After the instrument recognizes it successfully, the instrument reads stably, press the "Next" to complete the calibration.

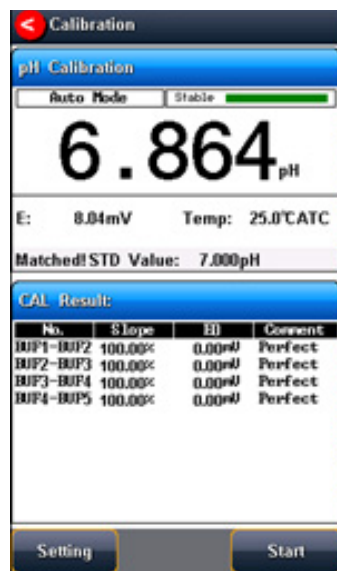

Figure 5-23 pH electrode calibration information

9. After completing the calibration, press the “Enter” key to complete the calibration, save the calibration results and end the calibration, directly enter the start interface. If the checked standard solution group is 8, automatically end the calibration after eight points of calibration.

**TIPS**

The meter will not save the date if the calibration results are not confirmed.

### 5.5.4 pH Measurement

The measurement process is as follows:

1. Select a method. The method includes the parameter (e.g., pH), reading mode (e.g., continuous reading, auto-reading, or timed format).
2. Connect the ATC probe or enter the temperature manually.
3. Rinse the pH electrode with DI water, dry out.
4. Put the electrode into test solution under test.
5. Put the measurement end of the electrode into the sample solution.
6. Press “Measure” to enter into measurement status.
7. When the reading is stable, read the results.
8. Press the “Save” to save the measurement results and press the “Output” to print the result.
9. Between measurements, stored pH electrode in distilled or deionized water.
10. After measurement, rinse the pH electrode with deionized water thoroughly.

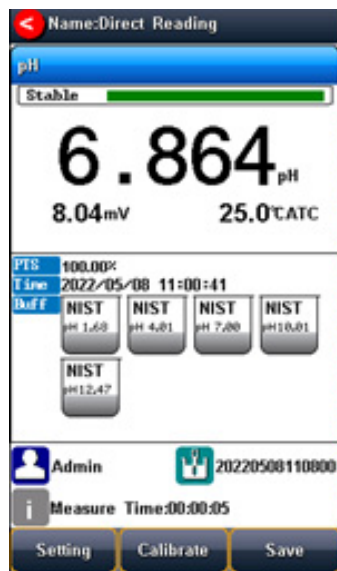

Figure 5-24 pH measurement information

**TIPS**

- The measurement end of the electrode should well be immersed into the sample solution.
- For high accuracy measurement, make sure the measurement is carried out at the lab with constant temperature and pressure.

### 5.6 Ion measurement

#### 5.6.1 Preparation

The slope and zero potential value of the ion electrode will change with time, so the ion electrode needs to be calibrated before use, and the instrument supports up to 6-point calibration. For the specific use of the electrode, please refer to the electrode manual.

### ■ Ion-selective electrode

The ion-selective electrode is based on the ion-selective membrane, which can be divided into single crystal membrane, salt membrane, glass membrane and PVC ion-selective membrane. Ion-selective electrodes usually have single electrodes and composite electrodes. Single electrode can be used with different reference electrodes, and has better measurement performance for some low-concentration ions. Composite electrodes are more convenient and simpler in the operation. You could be flexible to choose according to the requirements.

### ■ Ionic strength adjustment buffer

The use of ion electrodes to measure ion concentration requires the addition of ionic strength adjustment buffer.

The ionic strength of a solution has an important influence on the measurement of ion concentration. On the one hand, the ion-selective electrode directly measures the activity of the ion,  $a = \gamma c$ . Wherein,  $a$  is the activity of the ion,  $\gamma$  is the activity coefficient of the ion, and  $c$  is the ion concentration. Usually, the activity coefficient  $\gamma$  is affected by the ionic strength in the solution. By adding ionic strength adjustment buffer to the standard solution and the test solution, the measured solution has a similar ionic strength to the standard solution, there by having a similar activity coefficient  $\gamma$ . On the other hand, is a solution with low ionic strength, the potential of the reference electrode will show instability. The addition of the ionic strength adjustment buffer can help stabilize the reference electrode.

Various ion measurement needs various ionic strength adjustment buffer. Common ionic strength adjustment buffers are recommended in the following table.

Ion category	Ionic strength adjustment buffer
Na+	0.2 mol/L diisopropylamine
F-	0,1 mol/L NaCl o TISAB
Cl-	0,1 mol/L KNO <sub>3</sub>
Br-	0,1 mol/L KNO <sub>3</sub>
I-	0,1 mol/L KNO <sub>3</sub>
Ag+	0,1 mol/L NaNO <sub>3</sub>
Cu <sup>2+</sup>	0,1 mol/L NaNO <sub>3</sub>
Pb <sup>2+</sup>	0,1 mol/L KNO <sub>3</sub>
S <sup>2-</sup>	0,1 mol/L KNO <sub>3</sub>
K+	0,05 mol/L MgAc <sub>2</sub>
Ca <sup>2+</sup>	0,1 mol/L KCl
NO <sub>3</sub> -	0,1 mol/L NaH <sub>2</sub> PO <sub>4</sub>
BF <sub>4</sub> -	0,1 mol/L Na <sub>2</sub> SO <sub>4</sub>
ClO <sub>4</sub> -	0,1 mol/L NaCl

\* The final concentration of the ionic strength modifier in the standard or sample.

### ■ Standard solutions preparation

The best way to prepare standards is to use serial dilutions. Sequential dilution refers to diluting an initially prepared standard using a volumetric flask to obtain a second standard. Dilute the second standard to prepare a third standard. And so on until the required standard solution is obtained. In general, the concentration between two adjacent levels is a 10-fold relationship.

### ■ Activation of the ISE electrodes

When the electrode is used for the first time or has not been used for a long time, an activation is recommended. The electrode has better measurement performance after activation.

Table 5-5 Ion electrode activation solution and activation time recommendation

Ion category	Activation solution	Activation time
Na <sup>+</sup>	10-3 mol/L NaCl	2h
F <sup>-</sup>	10-3 mol/L NaF	2h
Cl <sup>-</sup>	10-3 mol/L KCl	2h
Br	10-3 mol/L NaBr	2h
I <sup>-</sup>	10-3 mol/L NaI	2h
Ag <sup>+</sup>	10-3 mol/L AgNO <sub>3</sub>	2h
Cu <sup>2+</sup>	10-3 mol/L Cu (NO <sub>3</sub> ) <sub>2</sub>	2h
Pb <sup>2+</sup>	10-3 mol/L Pb (NO <sub>3</sub> ) <sub>2</sub>	2h
S <sub>2</sub> <sup>-</sup>	10-3 mol/L AgNO <sub>3</sub>	2h
K <sup>+</sup>	10-3 mol/L KCl	2h
Ca <sup>2+</sup>	10-3 mol/L CaCl <sub>2</sub>	2h
NO <sub>3</sub> <sup>-</sup>	10-3 mol/L NaNO <sub>3</sub>	2h
BF <sub>4</sub> <sup>-</sup>	10-3 mol/L NaBF <sub>4</sub>	2h
ClO <sub>4</sub> <sup>-</sup>	10-3 mol/L NaClO <sub>4</sub>	2h



#### TIPS

The activation time may vary based on various activation solutions. See the ion-selective electrode manual for specifications.

## ■ Stirrer setting

The flow state of the solution influences the electrode potential of the ion-selective electrode. To improve the stability and repeatability of the measurement, it is recommended to use a stirrer to keep the flow rate of the solution stable during calibration and measurement.

### 5.6.2 Direct reading measurement

Direct Reading Measurement is commonly used ion concentration measuring method. The Direct Reading mode uses the following Nernst formula to calculate the concentration:

$$E_x = E_0 + S \times \log(C_x + C_b)$$

Wherein,

$E_x$  ~ Equilibrium potential of the sample solution, in mV.

$E_0$  ~ zero potential value, in mV.

$S$  ~ Electrode slope (%).

$C_x$  ~ Concentration value of the sample solution, in mol/L.

$C_b$  ~ Blank concentration value in mol/L.

The electrode slope and zero potential value can be known from the calibration. When measuring the sample solution, the sample concentration result can be calculated from the formula. The direct-reading method is fast and suitable for quick test measurement of common samples.

## ■ pX/ISE Calibration

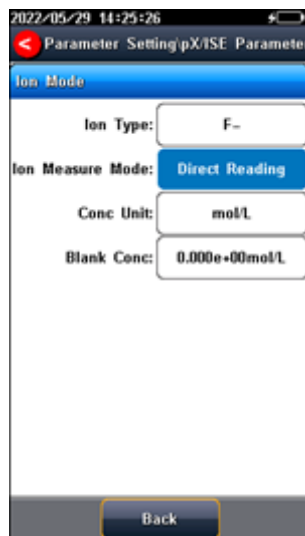



Figure 5-25 Ion measurement mode

The pX/ISE calibration process is as follows:

1. Select the "Direct Measure Method".

The method includes:

- 1) Set the parameters (e.g. pX).
- 2) Set the ion mode (e.g. F-).
- 3) Set the direct reading as ion measure mode.
- 4) Set the concentration unit (e.g. mol/L).
- 5) Set the blank concentration (e.g., 0.000 mol/L).
2. Add an appropriate amount of standard solution (usually 100 ml) to the beaker, then add ionic strength adjustment buffer. Adjust the stirring speed of the solution for measurement.
3. Press the F2 "Calibrate" -> "pX Calibration".
4. Put the cleaned electrode into standard solution.
5. Press the F2 "STD value" to input the standard value of the standard solution.
6. Wait for the reading is stable, press the .
7. If only 1-point calibration is required, after 1-point calibration is completed, press the  to complete the calibration.
8. If choosing multi-points calibration (up to 8), press "Next" to repeat the operation.
9. If the checked standard solution group is 8, automatically end the calibration after eight points of calibration.



#### TIPS

- Please re-calibration for an unexpected measurement result.
- A room temperature test solution is recommended.
- It is recommended to calibrate from low concentration to high concentration standards.

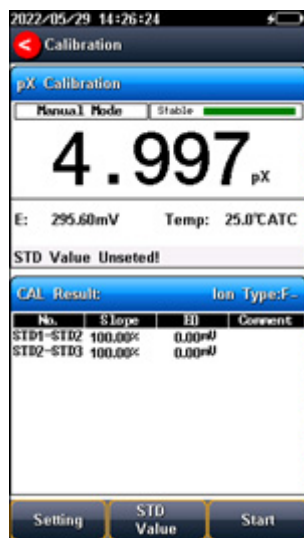



Figure 5-26 pX/ISE calibration information

## ■ Direct Reading Measurement

The measurement process is as follows:

1. Select the “Direct Measure Method”. The method includes the parameter (e.g., pX), the ion type (e.g., F-), reading mode (e.g., continuous reading, auto-reading, or timed format).
2. Or setting.
  - 1) Set the parameters (e.g., pX).
  - 2) Set the ion type (e.g., F-).
  - 3) Set the direct reading as ion measure mode.
  - 4) Set the concentration unit (e.g., mol/L).
  - 5) Set the reading mode (e.g., continuous reading, auto-reading, or timed format).
3. Add an appropriate amount of standard solution (usually 100 ml) to the beaker, then add ionic strength adjustment buffer. Adjust the stirring speed of the solution for measurement.
4. In the idle status, press  to enter into measurement status.
5. When the reading is stable, read the results.
6. Press the “Save” to save the measurement results.
7. Press the “Output” to print the measurement result when connect to the printer.
8. Between measurements, stored ISE electrode in distilled or deionized water.
9. After measurement, rinse the ISE electrode with deionized water thoroughly.

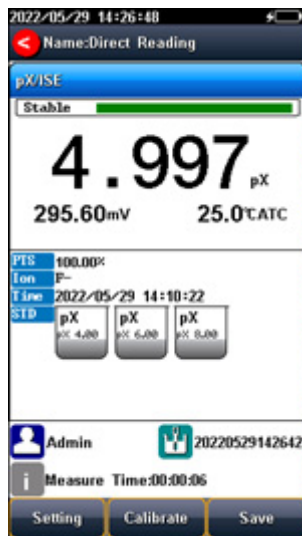

Figure 5-27  
pX/ISE measurement information



**TIPS** Different ISE probes have different potential values in a blank solution. If the blank potential is away from the reference value, the user can do an activation to improve the performance of electrodes. If the electrode still does not meet the requirements, a new electrode is quite considerable.

### 5.6.3 Standard addition method

Also known as the known additive method, it is mainly used to measure samples with tiny content. First, the equilibrium potential value of the system is determined, then a standard solution of known concentration is added to the system and the equilibrium potential value of the system is determined. From the potential change, the sample concentration result can be calculated by formula as follows:

$$C_x = \frac{\rho \times C_s}{(1 + \rho) \times 10^{(\frac{E_1 - E_2}{S})}} + \frac{\rho \times C_b}{(1 + \rho) \times 10^{(\frac{E_2 - E_{11}}{S})}}$$

Wherein,

$C_x$  ~ the concentration value of the sample solution, in unit mol/L.

$C_s$  ~ concentration value of the standard (addition solution), in mol/ L.

$S$  ~ electrode slope (%).

$C_b$  ~ blank standard concentration value in mol/L.

$E_1$  ~ The potential value before the standard addition, in mV.

$E_2$  ~ The potential value after the standard addition, in mV.

$\rho$  ~ Standard add volume ( $V_s$ ) / volume of sample to be tested ( $V_x$ ).

$E_{b1}$  ~ The potential value before standard of calibration, in mV.

$E_{b2}$  ~ The potential value after standard of calibration, in mV.

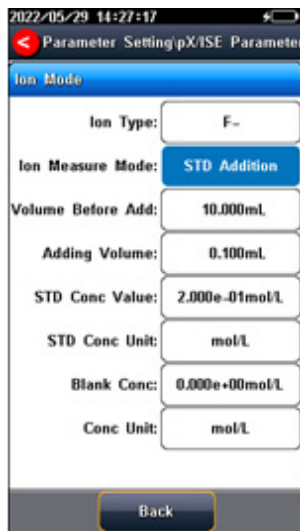



Figure 5-28  
Standard addition method ion measurement mode

The standard addition measurement process is as follows:

1. Select the “STD Addition Method”.

The method includes:

- 1) Set the parameters (e.g., Ion Conc).
- 2) Set the ion type (e.g., F-).
- 3) Set the Standard Addition as ion measure mode.
- 4) Set “Volume Before Add”, “Adding Volume”, “STD Conc Value”, “STD Conc Unit”, “Blank Conc” and “Conc Unit”.
- 5) Set the concentration unit (e.g., ppm).
- 6) Set the reading mode (e.g., continuous reading, auto-reading, or timed format).
2. Add an appropriate amount of sample solution (usually 100 ml) to the beaker, then add ionic strength adjustment buffer. Adjust the stirring speed of the solution for measurement.
3. Put the cleaned electrode into standard solution.
4. Press the **Measure** .
5. Press “Next” after the reading is stable.
6. Follow the prompts to add the preset standard.
7. Press “Next” to measure the potential value of solution.
8. After the reading is stable, press “Next” to end the measurement.
9. The results are shown by auto calculation.
10. Press the “Save” to save the measurement results.
11. Press the “Output” to print the measurement result when connect to the printer.

### ■ Sample addition method

The method is similar to the standard addition method and is mainly used to measure samples with high content sample solutions. The standard is replaced by samples to add to the sample solution. The calculation formula is as follows:

$$C_x = C_s \times [(1 + \rho) \times 10^{(E_1 - E_2)/S} - \rho]$$

Wherein,

$C_x$  ~ the concentration value of the sample solution (addition solution), in mol/L.

$C_s$  ~ concentration value of the standard, in mol/L.

$p$  ~ Volume of the standard ( $V_s$ )/ Volume of the sample to be tested ( $V_x$ ).

$E_1$  ~ The potential value before the sample addition, in mV.

$E_2$  ~ The potential value after the sample addition, in mV.

$S$  ~ Electrode slope (%).

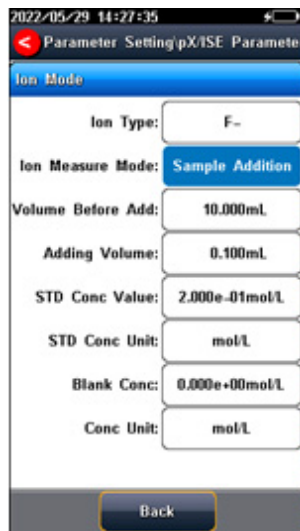



Figure 5-29

Sample addition method ion measurement mode

The sample addition measurement process is as follows:

1. Select the "Sample Addition Method".

The method includes:

- 1) Set the parameters (e.g., Ion Conc).
- 2) Set the ion type (e.g., F-).
- 3) Set the sample addition as ion measure mode.
- 4) Set "Volume before add", "Adding Volume", "STD Conc Value", "STD Conc Unit", "Blank Conc", and "Conc Unit".
- 5) Set the concentration unit (e.g., mol/L).
- 6) Set the reading mode (e.g., continuous reading, auto-reading, or timed format).
2. Add an appropriate amount of standard solution (usually 100 ml) to the beaker, then add ionic strength adjustment buffer. Adjust the stirring speed of the solution for measurement.
3. Put the cleaned electrode into standard solution.
4. Press the .
5. Press "Next" after the reading is stable.
6. Follow the prompts to add the preset sample.
7. Press "Next" to measure the potential value of solution.
8. After the reading is stable, press "Next" to end the measurement.
9. The results are shown by auto calculation.
10. Press the "Save" to save the measurement results.
11. Press the "Output" to print the measurement result when connect to the printer.

## ■ GRAN method

The measurement process is like the standard addition method, mainly for measuring samples with low content. According to the mathematical principle of GRAN mode, the ion concentration results of the sample can be calculated using the following equation:

$$(V_x + V_s) \times 10^{E_x/S} = 10^{E_0/S} \times (C_x V_x) + 10^{E_0/S} \times (C_s V_s)$$

Wherein,

$C_x$  ~ the concentration value of the sample solution (addition solution), in mol/L.

$C_s$  ~ concentration value of the standard, in mL.

$V_s$  ~ volume of standard, in mL.

$V_x$  ~ Volume of the sample to be tested in mol/L.

$E_x$  ~ The equilibrium potential of the sample solution (sample), in mV.

$E_0$  ~ zero potential value, in mV.

$S$  ~ electrode slope (%).

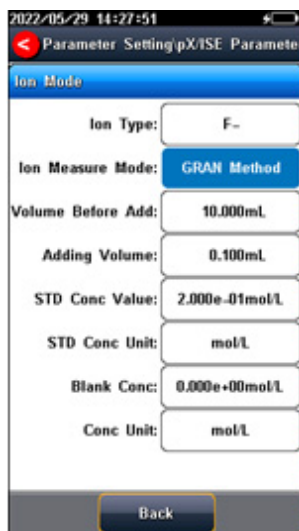



Figure 5-30  
Ion measurement mode of GRAN measurement method

The GRAN measurement process is as follows:

1. Select the "GRAN Method".

The method includes:

- 1) Set the parameters (e.g., Ion Conc).
  - 2) Set the ion type (e.g., F-).
  - 3) Set the GRAN as ion measure mode.
  - 4) Set "Volume Before Add", "Adding Volume", "STD Conc Value", "STD Conc Unit", "Blank Conc", and "Conc Unit".
  - 5) Set the concentration unit (e.g., mol/L).
  - 6) Set the reading mode (e.g., continuous reading, auto-reading, or timed format).
2. Add an appropriate amount of sample solution (usually 100 ml) to the beaker, then add ionic strength adjustment buffer. Adjust the stirring speed of the solution for measurement.
  3. Put the cleaned electrode into standard solution.
  4. Press the 

5. Press “Next” after the reading is stable.
6. Follow the prompts to add the preset standard.
7. Press “Next” to measure the potential value of solution.
8. After the reading is stable, repeat the step 6 and step 7 for 3 or 8 times.
9. The results are shown by auto calculation.
10. Press the “Save” to save the measurement results.
11. Press the “Output” to print the measurement result when connect to the printer.

**TIPS**

- Please re-calibrate for an unexpected measurement result.
- A room temperature test solution is recommended.
- It is recommended to calibrate from low concentration to high concentration standards.

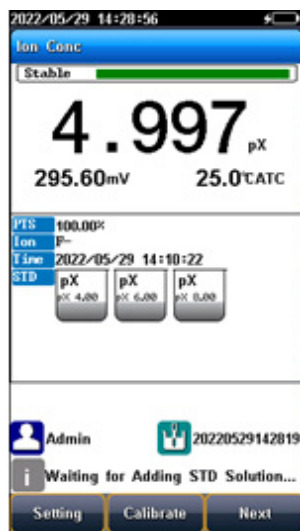

Figure 5-31 GRAN measurement Ion Conc information

**TIPS**

Different ISE probes have different potential values in a blank solution. If the blank potential is away from the reference value, the user can do an activation to improve the performance of electrodes. If the electrode still does not meet the requirements, a new electrode is quite considerable.

## 5.7 ORP Measurements

### 5.7.1 Calibration Preparation

In general, ORP electrodes need few calibrations. When the electrode is used for the first time or has not been used for a long time, a calibration is needed.

The instrument supports ORP 1-point calibration, the electrode can be calibrated using the ORP calibration solution. The instrument automatically calculates the offset and compensates for the measurement.

Before the calibration, prepare the ORP calibration standard solution.

### 5.7.2 ORP Calibration

The calibration process is as follows:

1. Select the "ORP Measure Method".

The method includes:

- 1) Set the parameters (e.g., ORP).
2. Connect the ATC probe or enter the temperature manually.
3. Press the "Calibrate" -"ORP Calibration".
4. Put the cleaned electrode into ORP standard solution (e.g., 462mV ORP standard).
5. Press the "STD value" to input the ORP standard value.
6. When the reading is stable, press the "Measure"  to complete the first point calibration, and the instrument displays and stores the calibration results.
7. Press the "End" key to complete the calibration.



#### TIPS

If the calibration process is not completed, the calibration will be ended, and the setting parameters will not be saved.

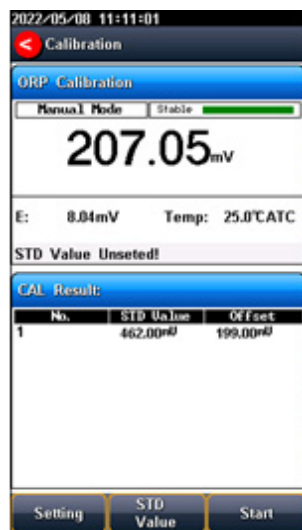

Figure 5-32 ORP electrode calibration information

### 5.7.3 ORP Measurement

The measurement process is as follows:

1. Select the “ORP Measure Method”.

The method includes:

- 1) Set the parameters (e.g., ORP).
- 2) Set the reading mode (e.g., continuous reading, auto-reading, or timed format).
2. Connect the ATC probe or enter the temperature manually.
3. Rinse the pH electrode with DI water, dry out.
4. Put the electrode into test solution under test.
5. Put the measurement end of the electrode into the sample solution.
6. Press “Measure” to enter into measurement status.
7. When the reading is stable, read the results.
8. Press the “Save” to save the measurement results and press the “Output” to print the result.
9. Between measurements, stored ORP electrode in distilled or deionized water.
10. After measurement, rinse the ORP electrode with deionized water thoroughly.



Figure 5-33 ORP measurement information

## 5.8 Conductivity Measurement

### 5.8.1 Cell Constant Input

Conductivity electrodes are precisely calibrated at the time of manufacture and marked with the exact cell constant. Before the measurement, press “Setting” - “EC Parameter” - “Electrode Constant” to enter the electrode cell constant.

### 5.8.2 Calibration Preparation

In general, conductivity electrodes need few calibrations. When the user gets an unexpected result, an electrode calibration is considerable.

Usually, single standard solution is required for calibration. For accurate measurement of sample conductivity above 50mS/cm, a two-point calibration is required. Two standards are required, a low conductivity standard and a conductivity standard close to the sample.

The meter provides various Standards Group including Universal Standard Group and GB group. And allows the user to prepare the customized Standard groups.

### 5.8.3 Conductivity Calibration



Figure 5-34  
Electrode cell constant calibration information



Figure 5-35 Electrode cell constant calibration result information

For conductivity electrodes with different cell constants, it is recommended to use the following conductivity standard solutions for calibration.

Table 5-6 KCl standards vs electrode cell constants

Cell constant (cm-1).	0.1	1	10
KCl solution concentration (mol/L).	0.001	0.01 or 0.1	0.1 or 1

The calibration process is as follows:

1. Press “Setting” -”EC Parameter”.
2. Press the “Constant type” to select the “1”.
3. Press “Cal. Type” to select the “Cal by Standards”.
4. Prepare one or more standard conductivity solution (e.g., 1413 $\mu$ S/cm conductivity solution).
5. Prepare a thermostatic bath, and set the temperature to (25.0 $\pm$ 0.1)  $^{\circ}$ C.
6. Place a standard conductivity solution in a thermostatic bath, and set the temperature to (25.0 $\pm$ 0.1)  $^{\circ}$ C.
7. Press the F2 “Calibrate” for one-parameter measurements or press the F2 “Calibrate”-”EC Calibration” for multi-parameter measurements.
8. Place the conductivity electrode into a standard solution.
9. When the conductivity and temperature reading (e.g.,1413 $\mu$ S/cm, 25.0 $^{\circ}$ C) are stable, press the “Start”.
10. If choosing one-point calibration, press “ Calibration “ to end the calibration.
11. If choosing multi-points calibration (up to 3), press “Next Point” to repeat the operation.
12. The meter saves calibration data automatically.



#### TIPS



The conductivity of the solution is greatly affected by temperature, it is recommended to use constant temperature water for calibration. Automatic or manual temperature compensation can also be optional when there is no water bath.

### 5.8.4 Conductivity Measurement



Figure 5-36  
Conductivity measurement  
information

The measurement process is as follows:

1. Setting.
  - 1) Set the parameters (e.g., conductivity).
  - 2) Set the reading mode (e.g., continuous reading, auto-reading, or timed format).
  - 3) Set the temperature compensation (e.g., Linear compensation, temperature compensation coefficient 2.00%/ $^{\circ}$ C).
  - 4) Set the reference temperature (e.g., 25 $^{\circ}$ C).
2. Rinse the conductivity electrode with DI water, dry out.
3. Put the measurement end of the electrode into the sample solution.
4. When the reading is stable, press “ Measure  “ to read the results.
5. Press the “Save” to save the measurement results.
6. Press the “Output” to print the measurement result when connect to the printer.
7. Between measurements, stored EC electrode in distilled or deionized water.
8. After measurement, rinse the EC electrode with deionized water thoroughly and put on the electrode protection cap.

## 5.9 TDS Measurements

TDS: Total dissolved solids refer to the total amount of all solutes in water, including the content of both inorganic and organic matter. In general, the higher the conductivity, the higher the salt, the higher the TDS.

### 5.9.1 TDS conversion factor

#### ■ Low Concentration TDS Sample

For samples with relatively simple composition and low concentration, TDS of solution can be estimated by conductivity. Compared with weighing method, TDS estimation by conductivity is relatively simple and convenient with quite good accuracy. For potassium chloride and sodium chloride solutions below 5000  $\mu\text{S}/\text{cm}$ , the TDS coefficient is approximately 0.5. Therefore, 0.5 can be used as the TDS coefficient for approximate estimation in most situations.

The conversion factor adjust process is as follows:

1. Press "Setting" -"TDS Parameter".
2. Select the TDSF CAL Type as the set TDS factor.
3. Input the TDS factor as the desired TDS coefficient.

Table 5-7 Conductivity vs TDS Standard Solution

Conductivity $\mu\text{S}/\text{cm}$	TDS standards		
	KCl (mg/L)	NaCl (mg/L)	442 (mg/L)
23	11.6	10.7	14.74
84	40.38	38.04	50.5
447	225.6	215.5	300
1413	744.7	702.1	1000
1500	757.1	737.1	1050
2070	1045	1041	1500
2764	1382	1414.8	2062.7
8974	5101	4487	7608
12880	7447	7230	11367
15000	8759	8532	13455
80000	52168	48384	79688

1. 442 indicates the solution contains 40%Na<sub>2</sub>SO<sub>4</sub>, 40%NaHCO<sub>3</sub>, 20%NaCl.

2. The values listed in the table are values at 25°C.

For KCl and NaCl solutions below 5000  $\mu\text{S}/\text{cm}$ , the TDS coefficient is about 0.5, so 0.5 can be used as an approximation in most cases.

## ■ High Concentrations TDS Sample Measurement

For samples with simple components and higher concentrations, such as high concentrations of NaCl solution, TDS factor re-calibration is needed.

For TDS measurements, the user may need to correct the TDS conversion factor by TDS standard.

The conversion factor calibration process is as follows:

1. Setting.
- 1) Set the parameters (e.g., TDS).
- 2) Press “Setting” -”TDS Parameter”.
- 3) Select the TDSF CAL Type as the set Cal by STD.
- 4) Set the reference temperature (e.g., 25°C).
2. Prepare TDS Standard.
3. Place a standard conductivity solution in a thermostatic bath, and set the temperature to  $(25.0 \pm 0.1) ^\circ\text{C}$ .
4. Rinse the conductivity electrode with DI water, dry out.
5. Put the measurement end of the electrode into the sample solution.
6. Press the F2 “Calibrate”-”TDS Calibration”.
7. Set the STD value as the sample STD value.
8. When the TDS and temperature reading (708ppm, 25.0°C) are stable.
9. If choosing one-point calibration, press “

No.	STD Value	Measured	TDS Factor
STD1	704ppm	704ppm	0.500
STD2	6.43ppm	6.43ppm	0.500
STD3	55.7ppm	55.7ppm	0.500

Figure 5-37 TDS coefficients calibration

## ■ Complex TDS Sample Measurement

For samples with complex compositions, the accuracy of TDS measurements can be improved by re-determination by laboratory methods and manual input of TDS coefficients. When the composition or concentration of the sample to be measured changes significantly, it is recommended to recalibrate the TDS coefficient.

The conversion factor calibration process is as follows:

1. Rinse the electrode with DI water. Put the measurement end of the electrode into the sample solution and set the temperature at  $(25.0 \pm 0.1) ^\circ\text{C}$ .
2. Using weighing method to determine the TDS.
3. Calculate the TDS coefficient.
4. Press “Setting” -”TDS Parameter”.
5. Select the TDSF CAL Type as the set TDS Factor.
6. Input the TDS factor as the desired TDS coefficient.

### 5.9.2 TDS Measurements

Users can switch the measurement parameter to TDS measurement by pressing Conductivity/TDS measurement box on the screen.

## 5.10 Salinity Measurement

The instrument can be used to determine the salinity of sodium chloride. The salinity of sodium chloride can be used to approximate the salinity of the solution being measured. By measuring the conductivity of the sample, the mass percentage of the corresponding sodium chloride solution can be calculated to convert the sodium chloride salinity.

Users can switch the measurement parameter to salinity measurement by pressing Conductivity/TDS measurement box on the screen. The detail refers to the measurement method of conductivity salinity measurement.

## 5.11 Resistivity Measurement

Resistivity and conductivity are reciprocal to each other, and conductivity can be measured at the same time when measuring resistivity.

Users can switch the measurement parameter to resistivity measurement by pressing Conductivity/TDS measurement box on the screen. The detail refers to the measurement method of conductivity measurement.

## 5.12 Ash Measurement

### 5.12.1 White Sugar Ash

The ash content of sugar refers to the percentage of the weight of the sample that remains after the organic matter is completely removed after burning in the sugar. Ash is an important indicator of white sugar. If the ash content exceeds the standard, the grade of white sugar will drop.

The conductivity ash measurement method is to dissolve a certain quality of white sugar in a certain volume of water to measure the conductivity value of the solution. Conductivity ash is calculated at 20°C as follows:

$$C = 6 \times 10^{-4} (C_1 - 0.35C_2)$$

Wherein,

C: Conductivity ash (%)

$C_1$ : 31.3 g/100 ml of the conductivity of the sugar solution at 20 °C,  $\mu\text{S}/\text{cm}$ .

$C_2$ : The conductivity of the distilled water at 20°C for sugar dissolving,  $\mu\text{S}/\text{cm}$ .

When the temperature is lower than 20 °C, the following formula can be used to compensate, generally applied in  $20 \pm 5$  °C.

$$C_{20^\circ\text{C}} = C_t / [1 + 0,026(t - 20)].$$

Wherein,

$C_{20^\circ\text{C}}$ : Conductivity value at 20°C,  $\mu\text{S}/\text{cm}$ .

$C_t$ : The actual measured conductivity value,  $\mu\text{S}/\text{cm}$ .

### 5.12.2 Fructose Glucose Syrup Ash

Fructose syrup Ash is measured similarly to the white sugar ash measurement method. Fructose syrup Ash calculation formula is as follows:

$$C = K * (C_1 - K_1 * C_2)$$

Wherein:

C: Fructose glucose syrup ash, % (g/100g).

K: The conversion coefficient of the solution conductivity converted to ash; the default is  $7.93 \times 10^{-4}$ .

K1: The correction coefficient of the solution with deionized water, default 0.39.

C1: 25% conductivity of the sugar solution at 25°C,  $\mu\text{S}/\text{cm}$ .

C2: Conductivity of dilution with deionized water at 25 °C,  $\mu\text{S}/\text{cm}$ .

### 5.12.3 Blank Measurement

There are 2 ways to measure blank values. It allows to input the blank value manually and measure the blank value in the calibration menu.

Manually enter the blank value for DI water in Parameter Settings - Conductivity Settings-Setting Ash Measurement Parameters.

The blank measurement process is as follows:

1. Select the Ash parameter.
2. Press “Calibrate” - “Calibrate ash blank conductivity”.
3. After the reading is stable, press “Start” to complete the measurement of the blank conductivity.

### 5.12.4 White Sugar Ash Measurement

The white sugar ash measurement process is as follows:

1. Calibrate the EC electrode.
2. Blank Measurement.
3. Select the “White Sugar Ash Method” in “Method Management”.
4. Dissolve a certain amount of white sugar in a certain volume of water (according to the ratio of 31.3g/100ml of sugar liquid).
5. Press  to start a measurement.

### 5.12.5 Fructose Glucose Syrup Ash Measurement

The fructose glucose syrup ash measurement process is as follows:

1. Calibrate the EC electrode.
2. Blank Measurement.
3. Select the “Fructose Slurry Ash Method” in “Method Management”.
4. Dissolve a certain amount of white sugar in a certain volume of water (according to the ratio of 31.3g/100ml of sugar liquid).
5. Press  to start a measurement.

## 5.13 Dissolved Oxygen Measurement

### 5.13.1 Calibration Preparation

#### ■ Preparation

Zero oxygen is calibrated using a freshly formulated 5% sodium sulfite solution as oxygen-free water.

## ■ Electrodes preparation

When the DO electrode (polarographic) is used for the first time or has not been used for a long time, the filling solution needs to be replaced.

Follow the below instruction to replace the filling solution:

1. Take the cap off the electrode, rinse the cap with DI water and dry out.
2. Rinse the inner electrode with DI water and dry the electrode.
3. Add the filling solution (electrolyte) into the membrane cap up to 3/4.
4. Install the cap onto the electrode.



### TIPS

- Membrane: The most important part, if damaged can lead to incorrect measurement.
- Electrolyte: Needs to be replaced every 2 weeks to 2 months, depending on the frequency of use.

## ■ Electrode Polarization

Polarographic DO electrodes need to be polarized before every use.

Connect the DO electrode to the meter and turn on the meter, wait for 1 hour and the electrode are auto polarized. When the electrodes are unplugged from the meter for no more than 1 hour, measurements are allowed after 25 minutes of polarization.

## ■ DO Calibration

After the measurement parameters are selected, press “Electrode Calibration”.

The calibration process is as follows:

1. Rinse the electrode with DI water, place it into oxygen-free solution.
2. when the reading is stable, press the “CAL Zero” to complete the zero calibration. Users can change the calibration parameters by pressing “parameter setting” during the calibration.
3. Rinse the electrode with DI water again, place the probe in the upper part of a bottle filled with air-saturated (well shaken) water.
4. When the reading is stable, press the “CAL Air-Sat” to complete the air calibration.



### TIPS

If the calibration process ends before it is completed, the set parameters are not saved.

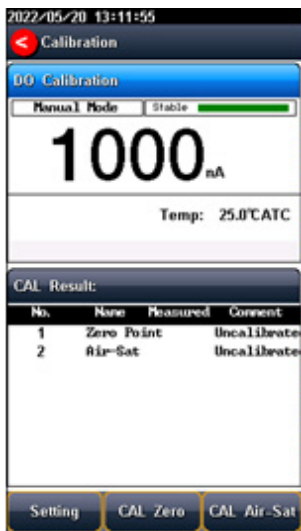

Figure 5-38 Dissolved oxygen calibration information

## ■ DO Measurement

After the calibration, press **Measure**  to start a measurement. The measurement process is as follows:

- Put the electrode into test solution under test and shake the electrode gently in a circle, or use a stirrer to avoid air bubbles during the process.
- When the reading is stable, end the measurement and save the results.



Figure 5-39 Dissolved oxygen measurement information



### TIPS

Polarographic dissolved oxygen electrodes slowly consume the oxygen from the sample. Therefore, reasonable stirring is required.

## 5.14 Saturation Measurement

Dissolved oxygen saturation refers to the ratio of the dissolved oxygen concentration to the saturated dissolved oxygen concentration under the same conditions.

Users can switch the measurement parameter to saturation measurement by pressing DO measurement box on the screen.

## 5.15 Data Management

### 5.15.1 Data Base

Press “Data” to view the detail of results.

The meter stores the measurement results independently according to the measured parameters. The meter provides storage 1000 sets for each parameter (pH/mV/ORP/EC/TDS/Salinity/Resistivity/Ash/DO/Saturation).

The user can press “Delete” into the delete menu. It allows users to select the parameter data or all data to delete.

The user can view the data filter by storage number, time, operator, method name, sample ID and electrode ID. By the filter setting, press “Start” to look up the data. The filter data shows in a graph. Press “<<” and “>>” to choose data. User can choose one and press “Detail” to see the detail result. User can choose one and press “Output” to output the current result, output matched result and output all result. Users can press “Operate” to the setting menu. In the operation menu, it allows to select the output type.

### 5.15.2 Statistics

The meter supports the statistical analysis function. By pressing “Statistic”, the meter calculates basic statistical results, including maximum, minimum, average, standard deviation, relative standard deviation, and related statistical information of the results.



Figure 5-40 Results setting view

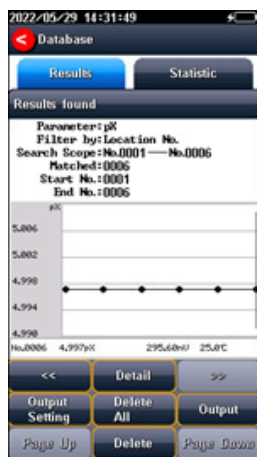

Figure 5-41 Results data graph



Figure 5-42 Output settings

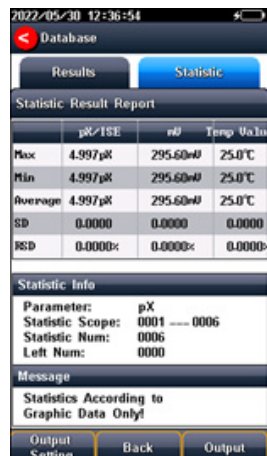

Figure 5-43 Statistical analysis

The output format is as follow::

```

*****
Report Title
-----
Measure Time:2021/01/19 12:27:28
Operator: Operator 1
Model: Nahita Multi-parameter Analyzer
Serial Number:
SW Version: Ver 1.00
-----
.....MATCHED INFO
Stored Num:
28
Matched Num:
1
Stored No.: 15
-----
.....CALIB INFO
Calib Operator: REX Team
Calib Time: 2020/05/13 08:30:00
Calib Num: 3
-----
.....CALIB RESULT
STD 1: 4.01pH 176.8mV 25.0c
STD 2: 7.00pH 0.0mV 25.0c
STD 3: 10.01pH -178.1mV 25.0c
pH Slope 1: 100.00%
pH E0 1:
0.0mV
pH Slope 2: 100.00%
pH E0 2:
0.0mV
-----
.....BRIEF INFO
Reading Mode: Timed
Reading
Stable Type:
Medium
Temp Comp Type:
ATC
-----
.....SAMPLE INFO
Sample ID: Sample 1
.....RESULT

```

## 6 MAINTENANCE/TROUBLESHOOTING

### 6.1 Meter Maintenance

The correct use and maintenance of the instrument can ensure the accurate and reliable performance of the instrument. Additionally, exposure to chemicals or harsh use environments can affect performance.

- If the meter is not used for a long time, please disconnect the power supply.
- The electrode socket of the instrument must be kept clean and dry, and should not be in contact with acid, alkali, and salt solutions.
- Keep the meter and accessories clean and away from acids, alkalis, and any corrosive solutions/gases.
- Users can clean the meter surface with clean waters and detergent.
- When the meter is transported, please follow the instructions:
  - Please remove all connected cables.
  - Please remove the electrode holder.
  - Please use original packaging in the long-distance transport to avoid damage.

### 6.2 Electrodes Maintenance

For more detailed information, please refer to the electrode instruction manual.

### 6.3 Troubleshooting

Table 6-1 Troubleshooting

Phenomenon	Probable reasons	Solutions
No visible display	<ol style="list-style-type: none"> <li>1. Not powered on.</li> <li>2. Damage to the meter.</li> </ol>	<ol style="list-style-type: none"> <li>1. Connect the adapter and press the power key to turn it on.</li> <li>2. Replace or repair as required.</li> </ol>
Incorrect mV measurement	<ol style="list-style-type: none"> <li>1. The electrode is out of service life.</li> <li>2. The electrode plug is in poor contact.</li> </ol>	<ol style="list-style-type: none"> <li>1. Replace the electrode.</li> <li>2. Connect the plug properly, if the potential is not 0mV, please contact the after-sales service.</li> </ol>
Incorrect pH measurement	<ol style="list-style-type: none"> <li>1. The electrode is out of service life.</li> <li>2. The electrode is not calibrated or is calibrated incorrectly.</li> </ol>	<ol style="list-style-type: none"> <li>1. Replace the electrode.</li> <li>2. Recalibrate the electrode or replace the standard solution.</li> </ol>
Incorrect pX/ISE measurement	<ol style="list-style-type: none"> <li>1. The electrode is out of service life.</li> <li>2. The electrode is not calibrated or is calibrated incorrectly.</li> <li>3. Incorrect ISE probe.</li> </ol>	<ol style="list-style-type: none"> <li>1. Replace the electrode.</li> <li>2. Recalibrate the electrode or replace the standard solution.</li> <li>3. Buy correct ISE probe. Add ionic strength adjustment buffer.</li> </ol>
Incorrect conductivity measurement	<ol style="list-style-type: none"> <li>1. The electrode is out of service life.</li> <li>2. The electrode is not calibrated or is calibrated incorrectly.</li> </ol>	<ol style="list-style-type: none"> <li>1. Replace the electrode.</li> <li>2. Recalibrate the electrode or replace the standard solution.</li> </ol>
Incorrect DO measurement	<ol style="list-style-type: none"> <li>1. The electrode is out of service life.</li> <li>2. The electrode is calibrated incorrectly.</li> <li>3. Stirring speed not good.</li> </ol>	<ol style="list-style-type: none"> <li>1. Replace the electrode.</li> <li>2. Recalibrate the electrode.</li> <li>3. Keep the bubbles in the stirring state consistent.</li> </ol>

If the meter still does not work, please contact your local dealer for further assistance.

## 7 APPENDIXES

### Appendix 1

pH-Temperature Relationship Table of pH Standard Solutions

Temperature (°C)	1.68	4.01	7.00	10.01
5	1.67	4.00	7.09	10.25
10	1.67	4.00	7.06	10.18
15	1.67	4.00	7.04	10.12
20	1.68	4.00	7.02	10.06
25	1.68	4.01	7.00	10.01
30	1.68	4.01	6.99	9.97
35	1.69	4.02	6.98	9.93
40	1.69	4.03	6.97	9.89
45	1.7	4.04	6.97	9.86
50	1.71	4.06	6.97	9.83

### Appendix 2

KCl solutions and their temperature-dependent conductivity values.

T (°C)	84 $\mu$ S/cm	1413 $\mu$ S/cm	12.88mS/cm
5	53.02	896	8.22
10	60.34	1020	9.33
15	67.61	1147	10.48
20	75.80	1278	11.67
25	84.00	1413	12.88
30	92.19	1552	14.12
35	100.92	1696	15.39
40	1.69	4.03	9.89
45	1.7	4.04	9.86
50	1.71	4.06	9.83