

STOMACHER®

User Instructions
Gebrauchsanweisung
Instrucciones del usuario
Mode d'emploi

80 Biomaster
80 *micro*Biomaster
400 Circulator
3500 Jumbo
3500 Biowasher
3500 Thermo



STOMACHER®
USER INSTRUCTIONS

Stomacher® is a registered Trademark and may not be used without the express permission of Seward Ltd.

Stomacher® ist eine eingetragene Marke und darf nicht ohne die ausdrückliche Genehmigung von Seward Ltd. verwendet werden.

Stomacher® es una marca registrada y no puede ser utilizada sin el permiso expreso de Seward Ltd.

Stomacher® est une marque déposée et ne doit pas être utilisée sans l'autorisation expresse de Seward Ltd.

STOMACHER®
USER INSTRUCTIONS

CONTENTS

1.	INTRODUCTION	3
2.	DESCRIPTION	3
3.	MARKINGS AND MEANINGS	4
4.	OPERATION (ALL MODELS)	5
4.1	Preparing For Use	5
4.2	Processing	6
4.2.1	Paddle Adjustment	6
4.3	After Processing	6
5.	STOMACHER® 80 BIOMASTER	7
5.1	Application	8
5.1.1	Bag Selection and Filling	8
5.1.2	Speed Selection	8
5.2	Control Key Functions	8
5.2.1	Instructions For Use	9
5.3	Specifications	10
5.3.1	UL-Designated and Japanese Products	10
5.3.2	EU and UK Products	11
6.	STOMACHER® 400 CIRCULATOR	12
6.1	Application	13
6.1.1	Bag Selection and Filling	13
6.1.2	Speed Selection	13
6.2	Operation	14
6.2.1	Control Key Functions	14
6.2.2	Display Icon Functions	15
6.2.3	Manual Operation	16
6.2.4	Automatic Operation	17
6.2.5	Storing Processing Programmes	17
6.2.6	Using Stored Processing Programmes	18
6.2.7	Stall Condition	18
6.3	Specifications	19
6.3.1	UL-Designated and Japanese Products	19
6.3.2	EU and UK Products	20
7.	STOMACHER® 3500 AND 3500 BIOWASHER	21
7.1	Application	22
7.1.1	Bag Selection and Filling	22
7.1.2	Speed Selection	22
7.2	Control Key Functions	Error! Bookmark not defined.
7.2.1	Instructions For Use	Error! Bookmark not defined.
7.3	Specifications	28
7.3.1	American and Japanese Products	28
7.3.2	EU and UK Products	29

STOMACHER®
USER INSTRUCTIONS

8.	STOMACHER® 3500 THERMO	30
8.1	Application	30
8.1.1	Bag Selection and Filling	30
8.1.2	Speed Selection	30
8.2	Control Key Functions	31
8.2.1	Instructions For Use Without Heater Function	32
8.2.2	Instructions For Use With Heater Function	32
8.3	Specifications	34
8.3.1	American Product	34
8.3.2	EU and UK Products	35
9.	MAINTENANCE	36
9.1	Cleaning	36
9.2	Replacing Primary Fuses	36
9.3	Servicing and Spare Parts	36
10.	WARRANTY AND SERVICE POLICY	37
11.	COMPLIANCE	37
12.	STORAGE AND TRANSPORT	37

STOMACHER®
USER INSTRUCTIONS

1. INTRODUCTION

This manual contains operating instructions for the *Stomacher® 80 Biowasher, 400 Circulator, 3500, 3500 Biowasher* and *3500 Thermo* models. Sections 5, 6, 7 and 8 respectively contain model-specific instructions. All other instructions are common.

The *Seward Stomacher®* was originally developed in conjunction with Unilever's Research Centre at Colworth House; Bedfordshire as a solution to many of the problems previously experienced in microbiological sample preparation. Subsequently it was decided to market the instrument in response to the interest expressed in the Stomaching technique to meet the ever-increasing demands for sample preparation in a fast, consistent and efficient way. Since then, *Seward* have continually developed the *Stomacher®* to maintain its position as the market leader ensuring exacting performance, high quality and exceptional reliability.

This manual provides the user with all the information to install, operate and maintain the *Seward Stomacher®*. Please read the manual carefully before using this equipment.

CAUTION: - This equipment should **not** be used if damaged in any way. If in doubt please contact your local *Seward* authorised service centre.

Should any other questions arise please do not hesitate to contact the *Seward Customer Service* Department on

Telephone: +44 (0)1903 236411

Facsimile: +44 (0)1903 219233

E-mail: info@seward.co.uk

2. DESCRIPTION

The *Seward Stomacher®* is a unique homogenising instrument in which the sample is blended within a special disposable bag. The instrument acts on the bag in an action similar to the action of a stomach, hence the name *Stomacher®*.

The instrument is comprised essentially of an electric motor-driven worm gear unit with twin output shafts coupled to flexible crank mechanisms, which in turn operate two reciprocating paddles. The paddles act on the flexible plastic bag to create the blending forces termed the 'stomaching' action. An important feature of the system is that the working parts do not come into direct contact with the sample being processed. The main body of the instrument is aluminium alloy, finished with durable hygienic paint; the door and linkage assemblies are stainless steel. All the control functions and displays are ergonomically grouped and conveniently situated.

In broad terms, the main difference between each of the different *Stomacher®* models is the sample capacity (the *Stomacher® 3500 Biowasher* has the same bag capacity as the *3500* and *3500 Thermo* although the bag compartment is larger to allow for uncompressible samples). The *Stomacher® 3500 Thermo* is also equipped with a heated door panel to allow sample heating to be carried out during the stomaching process.

Protection from the moving parts inside the sample compartment is provided by an automatic cut-out switch, which is activated when the door is opened, switching off the paddle operation (and also the heater blanket in the case of the *Stomacher® 3500 Thermo*).

STOMACHER®
USER INSTRUCTIONS

3. MARKINGS AND MEANINGS

Markings applied to the *Seward Stomacher*® have the following meanings: -



Attention, Consult User Instructions



Alternating Current



Power Off



Power On



Protective Earth



Conductive Earth

STOMACHER®
USER INSTRUCTIONS

4. OPERATION (ALL MODELS)

4.1 Preparing For Use

Upon receipt of your *Seward Stomacher*® inspect the shipping carton for any signs of damage. Carefully unpack and inspect the instrument, reporting any obvious damage or missing parts to the supplier/dealer/carrier as appropriate.

The carton should contain the following items: -

1. One *Seward Stomacher*®.
2. Two Power cord sets for EU models.
3. One User Instructions Manual.
4. One sample sachet of *Seward Stomacher*® *Bags*.

Retain the shipping carton in case of a need to return the instrument or for long term storage.

We have tried to provide the correct power cord for your market area, although if you find that the plug is not compatible with the socket outlet available it will be necessary to obtain a suitable alternative cord set.

CAUTION: - *Seward Stomachers*® are designed to operate in ambient temperatures above 10°C. Therefore, if the instrument has been stored or transported at temperatures below 10°C it should be left in an ambient greater than 10°C, for at least two hours prior to use.

CAUTION: - Before connecting the instrument to a power supply, check that the voltage and frequency details shown on the instrument are compatible with your mains electrical supply. The instrument **must only** be connected to a protectively earthed mains electrical supply. In the event of uncertainty, a competent qualified electrician should be consulted.

CAUTION: - Ensure that the instrument is **not** positioned directly against a wall or other equipment such that the ventilation slots are obstructed or restricted; we recommend that a minimum of 75mm (3") clear space around the unit is maintained.

CAUTION: - If this equipment is used in a manner not specified by *Seward*, protection provided by the equipment may be impaired.

Connect the *Seward Stomacher*® to the mains electrical socket using the power cord supplied. Ensure that the door is properly closed with the slotted lower hinge lugs located fully into the pivot points. Operate the power switch, which should illuminate indicating that the instrument is now ready for use.

STOMACHER®
USER INSTRUCTIONS

4.2 Processing

The *Stomacher® 80 Biomaster* and *400 Circulator* are factory-set with minimal paddle clearance between the inner face of the door and the fully extended paddles. On the *Stomacher® 3500, 3500 Biowasher* and *3500 Thermo*, the clearance is set to 10mm. Although suited to a wide range of applications these settings are by no means suitable for all sample processing and adjustment may be necessary for your application.

Provision for this adjustment is provided inside the instrument. Since this requires the removal of the rear cover a competent qualified technician should carry out this work.

4.2.1 Paddle Adjustment.

Switch off and disconnect the instrument from the mains electrical supply. Turn the instrument over, suitably supporting it to prevent damage. Remove the rear cover and slacken the socket cap screws holding the motor carriage to the main body via the slotted holes. **Do not** slacken any of the screws within the carriage assembly or the motor alignment will be lost. Remove the large hexagon headed blanking plug (if fitted) from the rear chassis to access the adjusting screw. Turn the adjusting screw until each paddle just touches the inside face of the door when they are at their maximum forward stroke position, this can be tested by manually rotating the gearbox output shaft. If the instrument is run briefly the alternate tapping noise of each paddle touching the door should just be audible. Take up any backlash in the adjusting screw and turn the screw back one to one and a quarter turns. This is the minimum clearance setting.

For a greater paddle clearance, each additional backward turn of the adjusting screw increases the clearance by 1.5mm up to a maximum of 10mm.

When adjustment is complete always re-tighten the socket cap screws, replace the hexagon headed blanking plug where fitted, and replace the rear cover.

The *Stomacher® 3500, 3500 Biowasher* and *3500 Thermo* are fitted with a neoprene rubber protective lining to the stomaching chamber to prevent any possibility of the bags being trapped behind the paddles, especially when using relatively small sample volumes.

Do not attempt to run the instrument without the protective lining in place.

4.3 After Processing

Due to the infinite variety of samples that may be processed in a *Stomacher®* it is not possible to provide definitive procedures for every application, or give any undertaking, implied or otherwise, as to the validity of any method used. *Seward Limited* maintain a library of reference papers covering practical experience with the *Stomacher®* system over many years and these details are available to users upon request.

STOMACHER® 80 BIOMASTER
USER INSTRUCTIONS

5. STOMACHER® 80 BIOMASTER

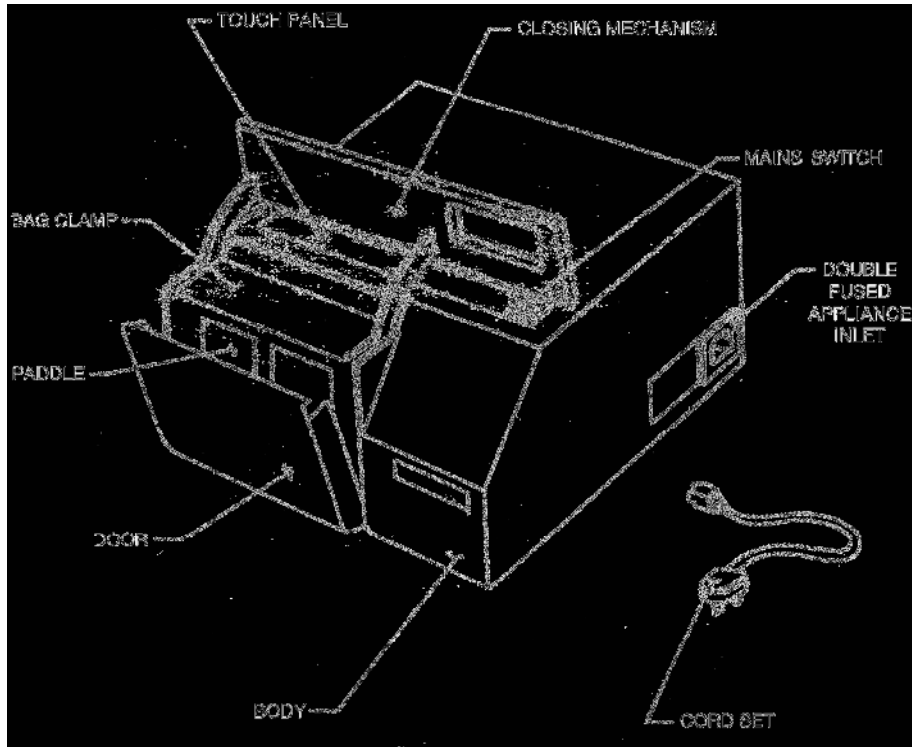

General Layout

STOMACHER® 80 BIOMASTER
USER INSTRUCTIONS

5.1 Application

There are no set rules in the application of the *Stomacher*® instrument and the following is intended as a guide only and not to restrict laboratory technique.

5.1.1 Bag Selection and Filling

For best results it is recommended that only genuine *Seward Stomacher*® Bags be used. Deep frozen foods should not harm the bags but hard particles such as bone, grit, fruit-stones and seeds may cause puncturing. Where a marginal condition exists or any hazardous material is being blended it is recommended that two bags are used one inside the other.

If required, several bags may be processed simultaneously providing the total volume does not exceed 80 ml. When doing so, it is recommended that they be layered vertically so that the 'load' is fairly evenly distributed over the paddle faces.

For volumes greater than 80ml, an alternative *Stomacher*® model should be used.

5.1.2 Speed Selection

The NORM. (normal) speed is suitable for the vast majority of applications and the instrument will always set automatically to that position upon powering up. If an alternative speed setting is desired this may be selected either prior to or during operation of the instrument. When depressed a short signal will be heard and the corresponding small indicator lamp at the top corner of the touch pad will illuminate.

The LOW speed may be more suitable for delicate work e.g. cell separation to reduce or avoid cell damage. Use of the HIGH speed can provide better agitation when blending predominantly liquid substances possibly reducing the processing time. In the event of the power being interrupted the speed setting will always revert to NORM.

5.2 Control Key Functions

The touch control panel, located on top of the *Stomacher*®, has the following functions: -

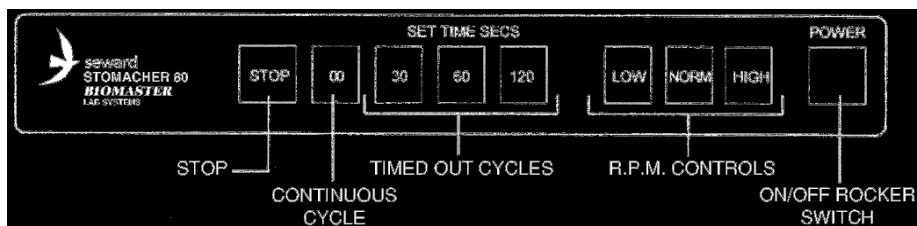

STOMACHER® 80 BIOMASTER
USER INSTRUCTIONS

5.2.1 Instructions For Use

1. Open the door by raising the handle fully upward and back. This gives access to the paddle compartment.
2. Place the bag(s) into the paddle compartment leaving 50 to 60mm protruding above the bag clamp and close the door thus clamping the bag(s).
3. When switching on, the POWER switch illuminates and the *Stomacher*® preselects the NORM. speed setting; the indicator in the touch pad shows this by illuminating. The timer is set at zero.
4. If required, either the LOW or HIGH speed can be selected by pressing the appropriate key. Note the audible signal and indicator illumination,
5. The stomaching process is initiated by the selection of a timed or continuous cycle. Again note the audible signal and indicator illumination.
6. The stomaching process continues in normal circumstances until either: -
 - A) The timed cycle has finished
 - B) The 'stop' control pad has been touched
 - C) The door has been opened
 - D) The power has been switched off

WARNING:- Opening the door during the operating cycle causes the instrument to stop. However, this must **not** be considered as the normal method for stopping the instrument.

If events B, C or D occur the timer automatically resets to zero.

7. After processing, simply open the door and remove the bag(s). The instrument is immediately ready for processing the next sample.

NOTE: -

A motor electrical current limiting device is incorporated into the control circuit. Upon initial start-up, a short time may elapse before the motor builds up torque and runs normally. This condition is more likely to prevail under the following circumstances:

- i) Upon initial start-up following a period of transportation or storage
- ii) The instrument has been stored in a cold environment (less than 10°C allowing the rubber connectors to become stiff).

For condition (i) run the instrument for 5-10 minutes, preferably with a number of stop-start cycles. For condition (ii) allow the instrument to stand in a warm environment as detailed in Section 5.3, followed by a short period of running with stop-start cycles.

STOMACHER® 80 BIOMASTER
USER INSTRUCTIONS

5.3 Specifications

5.3.1 American and Japanese Product

Model	Stomacher® 80 Biomaster
Cat No.	0080/000/AJ
Dimensions	290mm wide x 325mm deep x 190mm high (unpacked)
Weight	15kg (unpacked)
Supply Voltage	100-120V
Supply Frequency	50-60Hz
Mains Inlet Fuses*	T2.0A 250V 5x20mm, breaking capacity: 100A @ 250V
Transformer Fuse*	T250mA 250V 5x20mm, breaking capacity: 35A @ 250V
PCB Fuse*	F2.5A 250V 5x20mm, breaking capacity: 100A @ 250V
Insulation	Class 1 (Earthed)
Installation	Over Voltage Category II
Pollution	Pollution Degree 2
Duty Cycle	Continuous
Rated Load	55W
Disposable Bag Size	152mm x 101mm
Minimum Recommended Capacity	5ml
Maximum Recommended Capacity	80ml
Maximum Recommended Sample Temperature	60°C
Recommended Operating Ambient Temperature Range	10-35°C
Recommended Operating Relative Humidity Range	10-89%
Fixed Timer Settings	30 seconds (±5%) 60 seconds (±5%) 120 seconds (±5%) Continuous
No Load Paddle Speeds (@ nominal 20°C)	230rpm (±5%) LOW 265rpm (±5%) NORM. 300rpm (±5%) HIGH
Paddle Clearance	0-10mm

* Only these or equivalent UL-approved fuses should be used.

STOMACHER® 80 BIOMASTER
USER INSTRUCTIONS

5.3.2 EU Products

Model	Stomacher® 80 Biomaster
Cat No.	0080/000/EU
Dimensions	290mm wide x 325mm deep x 190mm high (unpacked)
Weight	15kg (unpacked)
Supply Voltage	220-250V
Supply Frequency	50-60Hz
Plug Top Fuse	F5A (UK cord set only)
Mains Inlet Fuses*	T800mA 250V 5x20mm, breaking capacity: 35A @ 250V
Transformer Fuse*	T250mA 250V 5x20mm, breaking capacity: 35A @ 250V
PCB Fuse*	F2.5A 250V 5x20mm, breaking capacity: 100A @ 250V
Insulation	Class 1 (Earthed)
Installation	Over Voltage Category II
Pollution	Pollution Degree 2
Duty Cycle	Continuous
Rated Load	55W
Disposable Bag Size	152mm x 101mm
Minimum Recommended Capacity	5ml
Maximum Recommended Capacity	80ml
Maximum Recommended Sample Temperature	60°C
Recommended Operating Ambient Temperature Range	10-35°C
Recommended Operating Relative Humidity Range	10-89%
Fixed Timer Settings	30 seconds (±5%) 60 seconds (±5%) 120 seconds (±5%) Continuous
No Load Paddle Speeds (@ nominal 20°C)	230rpm (±5%) LOW 265rpm (±5%) NORM. 300rpm (±5%) HIGH
Paddle Clearance	0-10mm

* Only these or equivalent UL-approved fuses should be used.

STOMACHER® 400 CIRCULATOR
USER INSTRUCTIONS

6. STOMACHER® 400 CIRCULATOR

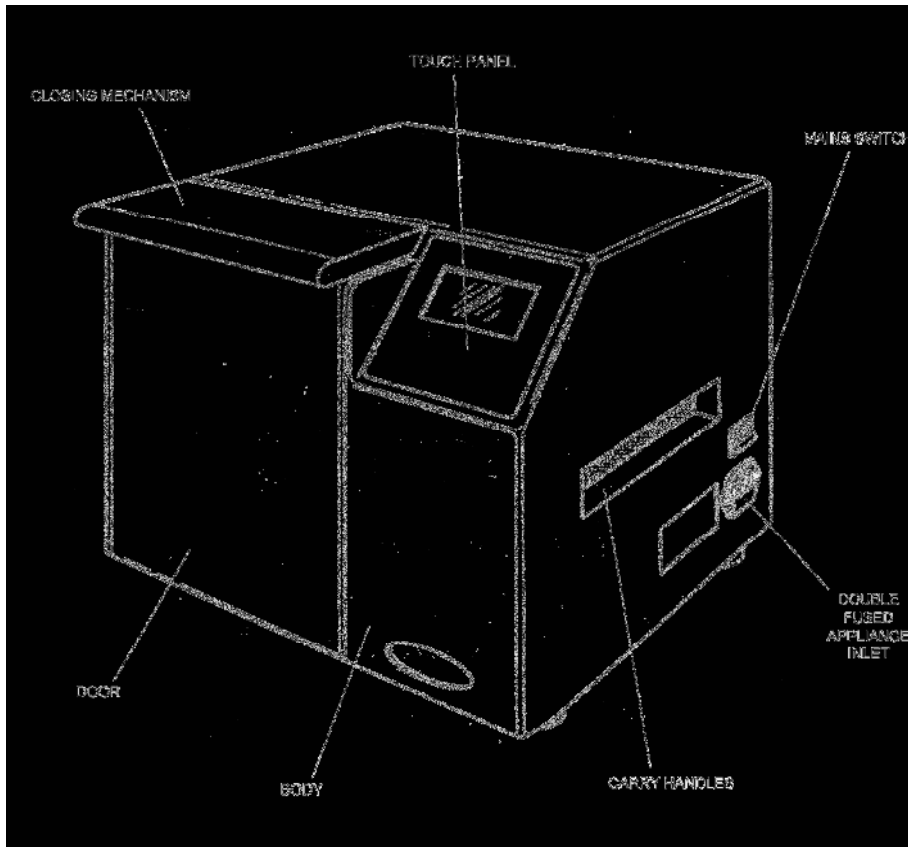

General Layout

STOMACHER® 400 CIRCULATOR
USER INSTRUCTIONS

6.1 Application

There are no set rules in the application of the *Seward Stomacher®* instrument and the following is intended as a guide only and is not to restrict laboratory technique.

6.1.1 Bag Selection and Filling

For best results it is recommended that only genuine *Seward Stomacher® Bags* be used. Deep frozen foods should not harm the bags, but hard particles such as bone, grit, fruit-stones and seeds may cause puncturing. Where marginal conditions exist or hazardous material is being blended it is recommended that two bags are utilised, one inside the other. For the vast majority of foods however, e.g. meats (cooked and raw), vegetables, fruit and cheeses the use of a single bag has proved to be entirely satisfactory.

If required, several bags may be processed simultaneously providing the total volume does not exceed 400ml. When doing so, it is recommended that the bags be layered vertically so that the 'load' is fairly evenly distributed over the paddle faces.

For capacities less than 80ml and greater than 400ml alternative *Stomacher®* models should be used.

6.1.2 Speed Selection

Paddle speed may be selected between 75rpm and 300rpm in 5rpm increments.

There are three pre-set program settings. P1 is 200rpm for 30 seconds, P2 is 230rpm for 45 seconds and P3 is 260 rpm for 60 seconds.

STOMACHER® 400 CIRCULATOR
USER INSTRUCTIONS

6.2 Operation

6.2.1 Control Key Functions

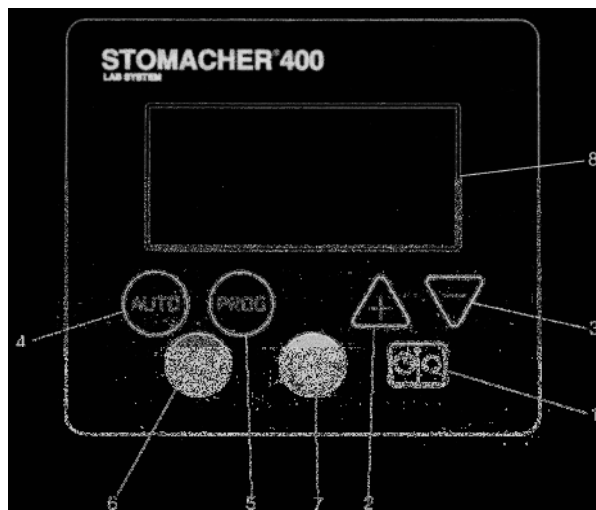

1. **SPEED / TIME key:** -
Toggles the display enunciator icon between SPEED and TIME displays.
2. **+ (PLUS) key:**-
Increases the value of the enunciated parameter, i.e. speed / time.
3. **- (MINUS) key:**-
Decreases the value of the enunciated parameter, i.e. speed / time.
4. **AUTO key:**-
Toggles the instrument between MANUAL and AUTO operating modes.
5. **PROG key:** -
Toggles through stored programme selection, P1, P2, P3 and no programme.
6. **START key:** -
Starts the instrument when in manual mode and initially in AUTO.
7. **STOP key:** -
Stops the instrument in either operational mode.
8. **Liquid Crystal Display:** -
Displays selected function values and status icons.

STOMACHER® 400 CIRCULATOR
USER INSTRUCTIONS

6.2.2 Display Icon Functions

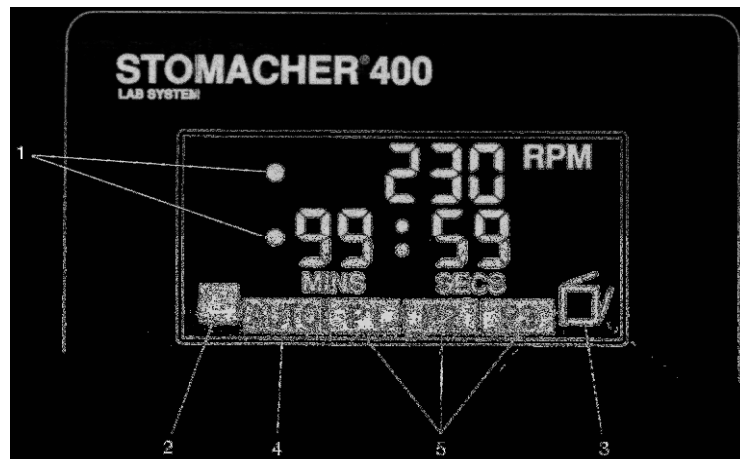

1. **ENUNCIATOR icon:** -
Continuously indicates whether the speed or time parameter has been selected.
2. **STALL CONDITION icon:** -
Displayed only when a motor stall condition has occurred.
3. **DOOR OPEN icon:** -
Displayed only when the door is open.
4. **AUTO icon:** -
Displayed only when AUTO mode is selected, there is no icon display for MANUAL mode.
5. **P1, P2, and P3 icons:** -
Displayed individually, when a stored programme is selected.

STOMACHER[®] 400 CIRCULATOR
USER INSTRUCTIONS

6.2.3 Manual Operation

Please note that pressing any control function key is acknowledged by a short tone (0.1 seconds duration) emitted from the instruments internal sounder.

1. Ensure the POWER rocker switch is in the on (1) position. The green lamp in the switch should be illuminated indicating that power is present and the instrument should also emit a short tone. The display should now indicate the instrument status.
2. Ensure the AUTO icon is **not** displayed. If AUTO is shown, press the AUTO key to revert to MANUAL mode. Similarly, if programmes, P1, P2, or P3 are selected, press PROG repeatedly until no programme is selected.
3. Open the door by raising the lid fully upward and back. This gives access to the paddle compartment. The DOOR OPEN icon will now be displayed.
4. Place the *Stomacher[®] Bag(s)* into the paddle compartment leaving 50 to 60mm protruding above the bag clamp and close the door thus clamping the bag(s). The DOOR OPEN icon will now be off.
5. The ENUNCIATOR icon indicates that the time parameter has been selected (display defaults to 30 seconds). The time parameter can now be adjusted by pressing the + or – key as required. The setting is variable between 0 seconds and 99 minutes 59 seconds in increments of 1 second. Pressing and releasing the + or – key increments the time by 1 second, holding down the + or – key accelerates the rate of change.
6. Pressing the SPEED / TIME key toggles the ENUNCIATOR icon to indicate that the speed parameter has been selected (display defaults to 230rpm). The speed setting can now be adjusted by pressing the + or – key as required.
7. Pressing the START key will initiate the stomaching process. The instrument will run at the selected speed and duration. Please note that the time display counts down from the selected time and displays the remaining processing time. The stomaching process continues in normal circumstances until either: -
 - The timed cycle has finished.
 - The STOP key is pressed.
 - The door has been opened.
 - The power has been switched off.

In all instances the time resets to the selected value.

8. After processing, simply open the door and remove the *Stomacher[®] Bag(s)*. The instrument is ready for processing the next sample.

WARNING: - Opening the door during the operating cycle causes the instrument to stop. This, however, **must not** be considered the normal method for stopping the instrument.

6.2.4 Automatic Operation

STOMACHER® 400 CIRCULATOR
USER INSTRUCTIONS

If a number of samples are to be processed under the same conditions, i.e. speed / time values, then you may prefer to select the AUTO mode. When in AUTO the stomaching process is initiated by the opening and closing of the door between sample loadings.

1. Select speed / time values as previously described in 6.2.3.
2. Press the AUTO key, displaying the AUTO Icon.
3. Load the charged *Stomacher® Bag(s)* as previously described in 6.2.3.
4. Closing the door will initiate the stomaching process. The instrument will run at the selected speed and duration. Please note that the time display counts down from the selected time and displays the remaining processing time. The stomaching process continues in normal circumstances until either: -
 - The timed cycle has finished.
 - The STOP key is pressed.
 - The door has been opened.
 - The power has been switched off.In all instances the time resets to the selected value.
5. When the processing is completed simply open the door, remove the processed sample and place the next sample into the instrument. Close the door and processing will commence automatically.

6.2.5 Storing Processing Programmes

It is possible to store up to three combinations of speed / time values as programmes within the instrument's memory. This enables the most frequently used or specific processing parameters to be recalled easily and efficiently.

To store or change a programme: -

1. Pressing and releasing the PROG key toggles through the three programme selections denoted by the P1, P2 and P3 icons and returns to manual (no PROG icon). Please note these initially display memory-stored default values. Press and release the PROG key at the desired programme number.
2. Adjust the speed / time values as described previously in 6.2.3.
3. Simultaneously press and hold down the AUTO key and PROG Key for at least 2 seconds. This is acknowledged by a longer tone (0.5 seconds' duration). The displayed speed / time values are stored in the memory.

STOMACHER® 400 CIRCULATOR
USER INSTRUCTIONS

6.2.6 Using Stored Processing Programmes

In Manual mode: -

1. Press and release the PROG key to select the desired programme. Either the P1, P2 or P3 icon should now be present on the display.
2. Load the *Stomacher® Bag(s)* as previously described.
3. Pressing the START key will initiate the stomaching process as previously described.
4. After processing, simply open the door and remove the *Stomacher® Bag(s)*. The instrument is ready for processing the next sample.

In Auto mode: -

1. Press and release the PROG key to select the desired programme. Either the P1, P2 or P3 icon should now be present on the display.
2. Press the AUTO key, displaying the AUTO icon.
3. Load the *Stomacher® Bag(s)* as previously described.
4. Closing the door will initiate the stomaching process as previously described.
5. When the processing is completed simply open the door, remove the processed sample and place the next sample into the instrument. Close the door and processing will commence automatically.

6.2.7 Stall Condition

The drive controller has a factory-set electrical current limiting device to protect the motor in the event of a stall condition occurring. In the event of a stall condition the STALL icon will be displayed on the control panel and the instrument will stop. This condition may simply occur due to overloading the paddles in which case the sample size should be reduced. (See 6.2.2 for LCD icons).

STOMACHER® 400 CIRCULATOR
USER INSTRUCTIONS

6.3 Specifications

6.3.1 UL-Designated Product

Model	Stomacher® 400 Circulator
Cat No.	0400/001/AJ
Dimensions	350mm wide x 335mm deep x 280mm high (unpacked)
Weight	23kg (unpacked)
Supply Voltage	100-120V
Supply Frequency	50-60Hz
Mains Inlet Fuses*	T2.0A 250V 5x20mm, breaking capacity: 100A @ 250V
Transformer Fuse*	T250mA 250V 5x20mm, breaking capacity: 35A @ 250V
PCB Fuse*	F2.5A 250V 5x20mm, breaking capacity: 100A @ 250V
Insulation	Class 1 (Earthed)
Installation	Over Voltage Category II
Pollution	Pollution Degree 2
Duty Cycle	Continuous
Rated Load	140W
Disposable Bag Size	177mm x 304mm
Minimum Recommended Capacity	80ml
Maximum Recommended Capacity	400ml
Maximum Recommended Sample Temperature	60°C
Recommended Operating Ambient Temperature Range	10-35°C
Recommended Operating Relative Humidity Range	10-89%
Adjustable Timer Settings	0 seconds - 99 minutes 59 seconds (±5%)
No Load Paddle Speeds (@ nominal 20°C)	75rpm to 300rpm in 5rpm increments (±5%)
Paddle Clearance	0-10mm

* Only these or equivalent UL-approved fuses should be used.

STOMACHER® 400 CIRCULATOR
USER INSTRUCTIONS

6.3.2 EU Product

Model	Stomacher® 400 Circulator
Cat No.	0400/001/EU
Dimensions	350mm wide x 335mm deep x 280mm high (unpacked)
Weight	23kg (unpacked)
Supply Voltage	220-250V
Supply Frequency	50-60Hz
Plug Top Fuse	F5A (UK cord set only)
Mains Inlet Fuses*	T1.0A 250V 5x20mm, breaking capacity: 35A @ 250V
Transformer Fuse*	T250mA 250V 5x20mm, breaking capacity: 35A @ 250V
PCB Fuse*	F2.5A 250V 5x20mm, breaking capacity: 100A @ 250V
Insulation	Class 1 (Earthed)
Installation	Over Voltage Category II
Pollution	Pollution Degree 2
Duty Cycle	Continuous
Rated Load	140W
Disposable Bag Size	177mm x 304mm
Minimum Recommended Capacity	80ml
Maximum Recommended Capacity	400ml
Maximum Recommended Operating Temperature	60°C
Recommended Operating Ambient Temperature Range	10-35°C
Recommended Operating Relative Humidity Range	10-89%
Adjustable Timer Settings	0 seconds – 99 minutes 59 seconds (±5%)
No Load Paddle Speeds (@ nominal 20°C)	75rpm to 300rpm in 5rpm increments (±5%)
Paddle Clearance	0-10mm

* Only these or equivalent UL-approved fuses should be used.

STOMACHER® 3500 AND 3500 BIOWASHER
USER INSTRUCTIONS

7. STOMACHER® 3500 AND 3500 BIOWASHER

General Layout

7.1

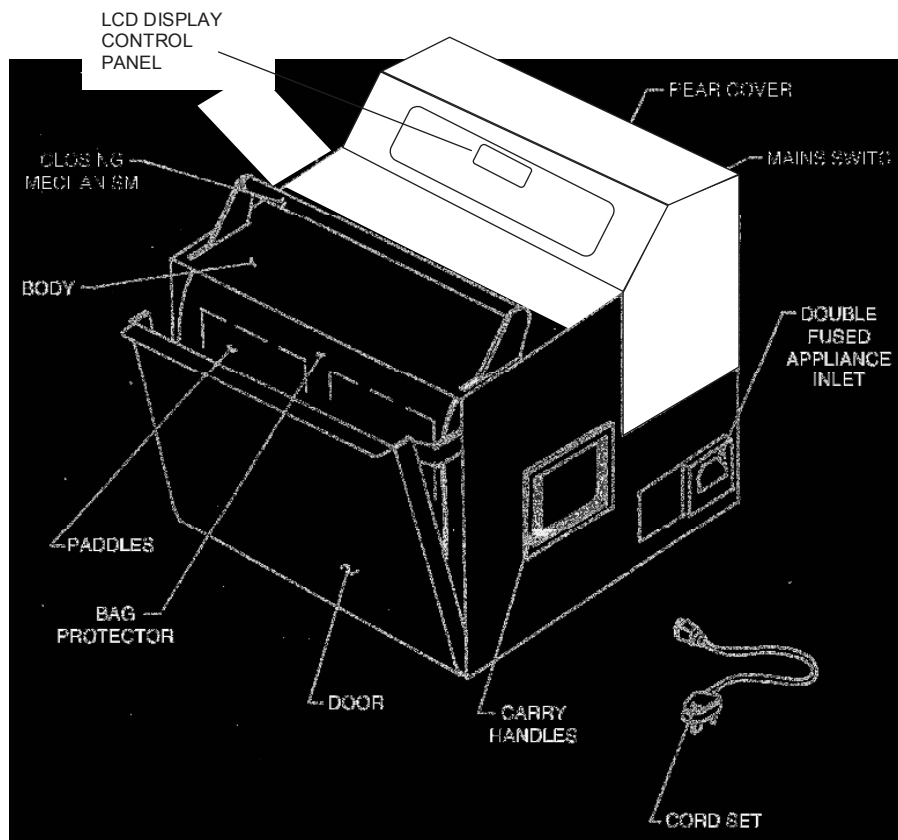

**STOMACHER® 3500 AND 3500 BIOWASHER
USER INSTRUCTIONS**

Application

There are no set rules in the application of the *Stomacher*® instrument and the following is intended as a guide only and not to restrict laboratory technique.

7.1.1 Bag Selection and Filling

For best results it is recommended that only Genuine *Seward Stomacher*® *Bags* be used. Deep frozen foods should not harm the bags but hard particles such as bone, grit, fruit-stones and seeds may cause puncturing. Where a marginal condition exists or any hazardous material is being blended it is recommended that two bags are used one inside the other.

If required, several bags may be processed simultaneously providing the total volume does not exceed 3500 ml. When doing so, it is recommended that they be layered vertically so that the 'load' is fairly evenly distributed over the paddle faces.

For volumes less than 400ml an alternative *Stomacher*® model should be used.

7.1.2 Speed Selection

7.1.3 Speed Selection

Paddle speed may be selected between 75rpm and 300rpm in 5rpm increments.

There are three pre-set program settings. P1 is 200rpm for 30 seconds, P2 is 230rpm for 45 seconds and P3 is 260 rpm for 60 seconds.

**STOMACHER® 3500 AND 3500 BIOWASHER
USER INSTRUCTIONS**

7.2 Operation

7.2.1 Control Key Functions

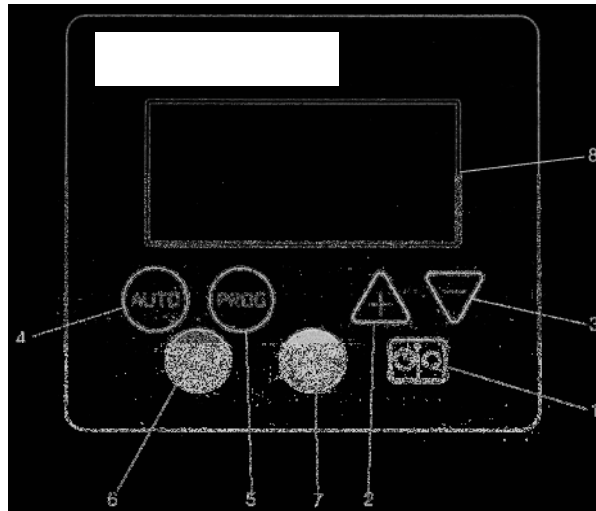

1. **SPEED / TIME key:** -
Toggles the display enunciator icon between SPEED and TIME displays.
2. **+ (PLUS) key:**-
Increases the value of the enunciated parameter, i.e. speed / time.
3. **- (MINUS) key:**-
Decreases the value of the enunciated parameter, i.e. speed / time.
4. **AUTO key:**-
Toggles the instrument between MANUAL and AUTO operating modes.
5. **PROG key:** -
Toggles through stored programme selection, P1, P2, P3 and no programme.
6. **START key:** -
Starts the instrument when in manual mode and initially in AUTO.
7. **STOP key:** -
Stops the instrument in either operational mode.
8. **Liquid Crystal Display:** -
Displays selected function values and status icons.

STOMACHER® 3500 AND 3500 BIOWASHER
USER INSTRUCTIONS

7.2.2 Display Icon Functions



1. **ENUNCIATOR icon:** -
Continuously indicates whether the speed or time parameter has been selected.
2. **STALL CONDITION icon:** -
Displayed only when a motor stall condition has occurred.
3. **DOOR OPEN icon:** -
Displayed only when the door is open.
4. **AUTO icon:** -
Displayed only when AUTO mode is selected, there is no icon display for MANUAL mode.
5. **P1, P2, and P3 icons:** -
Displayed individually, when a stored programme is selected.

STOMACHER® 3500 AND 3500 BIOWASHER
USER INSTRUCTIONS

7.2.3 Manual Operation

Please note that pressing any control function key is acknowledged by a short tone (0.1 seconds duration) emitted from the instruments internal sounder.

1. Ensure the POWER rocker switch is in the on (1) position. The green lamp in the switch should be illuminated indicating that power is present and the instrument should also emit a short tone. The display should now indicate the instrument status.
2. Ensure the AUTO icon is **not** displayed. If AUTO is shown, press the AUTO key to revert to MANUAL mode. Similarly, if programmes, P1, P2, or P3 are selected, press PROG repeatedly until no programme is selected.
3. Open the door by raising the lid fully upward and back. This gives access to the paddle compartment. The DOOR OPEN icon will now be displayed.
4. Place the *Stomacher® Bag(s)* into the paddle compartment leaving 50 to 60mm protruding above the bag clamp and close the door thus clamping the bag(s). The DOOR OPEN icon will now be off.
5. The ENUNCIATOR icon indicates that the time parameter has been selected (display defaults to 30 seconds). The time parameter can now be adjusted by pressing the + or – key as required. The setting is variable between 0 seconds and 99 minutes 59 seconds in increments of 1 second. Pressing and releasing the + or – key increments the time by 1 second, holding down the + or – key accelerates the rate of change.
6. Pressing the SPEED / TIME key toggles the ENUNCIATOR icon to indicate that the speed parameter has been selected (display defaults to 230rpm). The speed setting can now be adjusted by pressing the + or – key as required.
7. Pressing the START key will initiate the stomaching process. The instrument will run at the selected speed and duration. Please note that the time display counts down from the selected time and displays the remaining processing time. The stomaching process continues in normal circumstances until either: -
 - The timed cycle has finished.
 - The STOP key is pressed.
 - The door has been opened.
 - The power has been switched off.

In all instances the time resets to the selected value.

8. After processing, simply open the door and remove the *Stomacher® Bag(s)*. The instrument is ready for processing the next sample.

WARNING: - Opening the door during the operating cycle causes the instrument to stop. This, however, **must not** be considered the normal method for stopping the instrument.

7.2.4 Automatic Operation

STOMACHER® 3500 AND 3500 BIOWASHER
USER INSTRUCTIONS

If a number of samples are to be processed under the same conditions, i.e. speed / time values, then you may prefer to select the AUTO mode. When in AUTO the stomaching process is initiated by the opening and closing of the door between sample loadings.

1. Select speed / time values as previously described in 6.2.3.
2. Press the AUTO key, displaying the AUTO Icon.
3. Load the charged *Stomacher® Bag(s)* as previously described in 6.2.3.
4. Closing the door will initiate the stomaching process. The instrument will run at the selected speed and duration. Please note that the time display counts down from the selected time and displays the remaining processing time. The stomaching process continues in normal circumstances until either: -
 - The timed cycle has finished.
 - The STOP key is pressed.
 - The door has been opened.
 - The power has been switched off.In all instances the time resets to the selected value.
5. When the processing is completed simply open the door, remove the processed sample and place the next sample into the instrument. Close the door and processing will commence automatically.

7.2.5 Storing Processing Programmes

It is possible to store up to three combinations of speed / time values as programmes within the instrument's memory. This enables the most frequently used or specific processing parameters to be recalled easily and efficiently.

To store or change a programme: -

1. Pressing and releasing the PROG key toggles through the three programme selections denoted by the P1, P2 and P3 icons and returns to manual (no PROG icon). Please note these initially display memory-stored default values. Press and release the PROG key at the desired programme number.
2. Adjust the speed / time values as described previously in 6.2.3.
3. Simultaneously press and hold down the AUTO key and PROG Key for at least 2 seconds. This is acknowledged by a longer tone (0.5 seconds' duration). The displayed speed / time values are stored in the memory.

**STOMACHER[®] 3500 AND 3500 BIOWASHER
USER INSTRUCTIONS**

7.2.6 Using Stored Processing Programmes

In Manual mode: -

1. Press and release the PROG key to select the desired programme. Either the P1, P2 or P3 icon should now be present on the display.
2. Load the *Stomacher[®] Bag(s)* as previously described.
3. Pressing the START key will initiate the stomaching process as previously described.
4. After processing, simply open the door and remove the *Stomacher[®] Bag(s)*. The instrument is ready for processing the next sample.

In Auto mode: -

1. Press and release the PROG key to select the desired programme. Either the P1, P2 or P3 icon should now be present on the display.
2. Press the AUTO key, displaying the AUTO icon.
3. Load the *Stomacher[®] Bag(s)* as previously described.
4. Closing the door will initiate the stomaching process as previously described.
5. When the processing is completed simply open the door, remove the processed sample and place the next sample into the instrument. Close the door and processing will commence automatically.

7.2.7 Stall Condition

The drive controller has a factory-set electrical current limiting device to protect the motor in the event of a stall condition occurring. In the event of a stall condition the STALL icon will be displayed on the control panel and the instrument will stop. This condition may simply occur due to overloading the paddles in which case the sample size should be reduced. (See 6.2.2 for LCD icons).

**STOMACHER® 3500 AND 3500 BIOWASHER
USER INSTRUCTIONS**

7.3 Specifications

7.3.1 American and Japanese Products

Model	Sttomacher® 3500 and 3500 Biowasher
Cat No.	3500: 3500/000/AM, 3500/000/JA 3500 Biowasher: 3500/001/AM
Dimensions	480mm wide x 480mm deep x 445mm high (unpacked)
Weight	36kg (unpacked)
Supply Voltage	100-120V
Supply Frequency	50-60Hz
Mains Inlet Fuses*	T2.0A 250V 5x20mm, breaking capacity: 100A @ 250V
Transformer Fuse*	T250mA 250V 5x20mm, breaking capacity: 35A @ 250V
PCB Fuse*	F2.5A 250V 5x20mm, breaking capacity: 100A @ 250V
Insulation	Class 1 (Earthed)
Installation	Over Voltage Category II
Pollution	Pollution Degree 2
Duty Cycle	Continuous
Rated Load	120W
Disposable Bag Size	380mm x 508mm
Minimum Recommended Capacity	400ml
Maximum Recommended Capacity	3500ml
Maximum Recommended Sample Temperature	60°C
Recommended Operating Ambient Temperature Range	10-35°C
Recommended Operating Relative Humidity Range	10-89%
Timer Settings	0 seconds – 99 minutes 59 seconds (±5%)
No Load Paddle Speeds (@ nominal 20°C)	75rpm to 180rpm in 5rpm increments (±5%)
Paddle Clearance	0-20mm

* Only these or equivalent UL-approved fuses should be used.

**STOMACHER® 3500 AND 3500 BIOWASHER
USER INSTRUCTIONS**

7.3.2 EU and UK Products

Model	Sttomacher® 3500 and 3500 Biowasher
Cat No.	3500: 3500/000/EU and 3500/000/UK 3500 Biowasher: 3500/001/EU and 3500/001/UK
Dimensions	480mm wide x 480mm deep x 445mm high (unpacked)
Weight	36kg (unpacked)
Supply Voltage	220-250V
Supply Frequency	50-60Hz
Plug Top Fuse	F5A (UK cord set only)
Mains Inlet Fuses*	T1.0A 250V 5x20mm, breaking capacity: 35A @ 250V
Transformer Fuse*	T250mA 250V 5x20mm, breaking capacity: 35A @ 250V
PCB Fuse*	F2.5A 250V 5x20mm, breaking capacity: 100A @ 250V
Insulation	Class 1 (Earthed)
Installation	Over Voltage Category II
Pollution	Pollution Degree 2
Duty Cycle	Continuous
Rated Load	120W
Disposable Bag Size	380mm x 508mm
Minimum Recommended Capacity	400ml
Maximum Recommended Capacity	3500ml
Maximum Recommended Sample Temperature	60°C
Recommended Operating Ambient Temperature Range	10-35°C
Recommended Operating Relative Humidity Range	10-89%
Timer Settings	0 seconds – 99 minutes 59 seconds (±5%)
No Load Paddle Speeds (@ nominal 20°C)	75rpm to 180rpm in 5rpm increments (±5%)
Paddle Clearance	0 - 20mm

* Only these or equivalent UL-approved fuses should be used.

STOMACHER® 3500 Thermo
USER INSTRUCTIONS

8. STOMACHER® 3500 THERMO

8.1 Application

There are no set rules in the application of the *Stomacher*® instrument and the following is intended as a guide only and not to restrict laboratory technique.

8.1.1 Bag Selection and Filling

For best results it is recommended that only Genuine *Seward Stomacher*® *Bags* be used. Deep frozen foods should not harm the bags but hard particles such as bone, grit, fruit-stones and seeds may cause puncturing. Where a marginal condition exists or any hazardous material is being blended it is recommended that two bags are used one inside the other.

If required, several bags may be processed simultaneously providing the total volume does not exceed 3500 ml. When doing so, it is recommended that they be layered vertically so that the 'load' is fairly evenly distributed over the paddle faces.

For volumes less than 400ml an alternative *Stomacher*® model should be used.

8.1.2 Speed Selection

The NORM (normal) speed is suitable for the vast majority of applications and the instrument will always set automatically to that position upon powering up. If an alternative speed setting is desired this may be selected either prior to or during operation of the instrument. When depressed a short signal will be heard and the corresponding small indicator lamp at the top corner of the touch pad will illuminate.

The LOW speed may be more suitable for delicate work e.g. cell separation to reduce or avoid cell damage. Use of the HIGH speed can provide better agitation when blending predominantly liquid substances possibly reducing the processing time. In the event of the power being interrupted the speed setting will always revert to NORM (normal).

STOMACHER® 3500 Thermo
USER INSTRUCTIONS

8.2 Control Key Functions

The control panel, located on the top of the *Stomacher*®, has the following functions: -

1. POWER switch: powers up the *Stomacher*® and is illuminated when on.
2. TEMPERATURE CONTROLLER: allows the desired temperature setting to be selected between 20 and 50°C. The upper (green) display indicates the actual temperature and the lower (orange) display indicates the set or target temperature. The set temperature can be adjusted by: - Press the H (STAR) and ▲ (ARROW UP) keys to increase the set temperature. Press the H and ▼ (ARROW DOWN) keys to decrease the set temperature. Once set this data is stored until reset and retained when the *Stomacher* is switched off.
3. HEATER ON/OFF switch: the temperature controller will automatically adjust the heater when the HEATER switch is in the on position. The LED adjacent to the switch will illuminate to indicate when the heater is switched on.
4. CYCLE TIME CONTROLLER: allows the desired cycle run time setting to be selected between 0 and 99 minutes, 59 seconds. The upper display indicates the cycle run time remaining and counts down. The lower display indicates the set cycle run time. The cycle run time can be adjusted by pressing the appropriate green button on the controller to increment each digit in turn. Once set this data is stored until reset even if the *Stomacher*® is switched off.
5. The CYCLE switch enables the operator to select either of the following: -
 - TIMED - The *Stomacher*® runs at the selected speed for the duration of the selected time.
 - STOP - The *Stomacher*® will not run, but is still powered up. This switch does not control the heater.
 - CONTINUOUS - The *Stomacher*® runs at the selected speed continuously.
6. SPEED selector switch: enables LOW, MEDIUM or HIGH speed to be selected by turning the switch to the appropriate position.

STOMACHER® 3500 Thermo
USER INSTRUCTIONS

8.2.1 Instructions For Use Without Heater Function

1. Open the door by raising the handle fully upward and back. This gives access to the paddle compartment.
 2. Place the *Stomacher*® *Bag(s)* into the paddle compartment leaving 50 to 60mm protruding above the bag clamp and close the door thus clamping the bag(s).
 3. When switching on, the POWER switch illuminates.
 4. Select desired speed.
 5. If a timed cycle is required set the TIMER CONTROLLER as previously described.
 - 6A. Setting the CYCLE switch to the TIMED position initiates the stomaching process, which will continue until either: -
 - The timed cycle has timed out.
 - The CYCLE switch has been set to the STOP position
 - The door has been opened.
 - The power has been switched off.
 - 6B. Setting the CYCLE switch to the CONTINUOUS position initiates the stomaching process, which will continue until either: -
 - The CYCLE switch has been set to the STOP position.
 - The door has been opened.
 - The power has been switched off.
- WARNING:-** Opening the door during the operating cycle causes the instrument to stop. However, this **must not** be considered as the normal method for stopping the instrument.
7. After processing, simply open the door and remove the *Stomacher*® *Bag(s)*. The instrument is immediately ready for processing the next sample.

8.2.2 Instructions For Use With Heater Function

1. Open the door by raising the handle fully upward and back. This gives access to the paddle compartment.
2. Place the *Stomacher*® *Bag(s)* into the paddle compartment leaving 50 to 60mm protruding above the bag clamp and close the door thus clamping the bag(s).
3. When switching on, the POWER switch illuminates.
4. Set the desired processing temperature as previously described in 8.2.1 and switch the heater on.
5. Select the desired speed.
6. If a timed cycle is required set the TIMER CONTROLLER as previously described.

STOMACHER® 3500 Thermo
USER INSTRUCTIONS

- 7A. Actuating the cycle switch to the TIMED position initiates the stomaching process, which will continue until either: -
- The timed cycle has timed out.
 - The CYCLE switch has been set to the STOP position.
 - The door has been opened.
 - The power has been switched off.
- 7B. Setting the cycle switch to the CONTINUOUS position initiates the stomaching process, which will continue until either: -
- The CYCLE switch has been set to the STOP position.
 - The door has been opened.
 - The power has been switched off.
- WARNING:-** Opening the door during the operating cycle causes the instrument to stop. However, this **must not** be considered as the normal method for stopping the instrument.
8. After processing, simply open the door and remove the *Stomacher Bag(s)*. The instrument is immediately ready for processing the next sample.

NOTE: -

A motor electrical current limiting device is incorporated into the control circuit. Upon initial start up a short time may elapse before the motor builds up torque and runs normally. This condition is more likely to prevail under the following circumstances: -

- i) Upon initial start up following a period of transportation or storage.
- ii) The instrument has been stored or located in a cold environment (less than 10°C allowing the rubber connectors to become stiff).

For condition (i) run the instrument for 5-10 minutes, preferably with a number of stop-start cycles. For condition (ii) allow the instrument to stand in a warm environment as detailed in Section 8.3, followed by a short period of running with stop-start cycles.

STOMACHER® 3500 Thermo
USER INSTRUCTIONS

8.3 Specifications

8.3.1 American Product

Model	Sttomacher® 3500 Thermo
Cat No.	3500/002/AM
Dimensions	480mm wide x 480mm deep x 520mm high (unpacked)
Weight	40kg (unpacked)
Supply Voltage	100-120V
Supply Frequency	50-60Hz
Mains Inlet Fuses*	T6.3A 250V 5x20mm, breaking capacity: 63A @250V
Motor Transformer Fuse*	T250mA 250V 5x20mm, breaking capacity 35A @ 250V
Heater Transformer Fuse*	T10A 250V 5x20mm, breaking capacity 100A @ 250V
PCB Fuse*	6.3A 250V HRC ceramic 5x20mm, breaking capacity 100A @ 250V
Insulation	Class 1 (Earthed)
Installation	Over Voltage Category II
Pollution	Pollution Degree 2
Duty Cycle	Continuous
Rated Load	420W (of which heater is 300W)
Disposable Bag Size	380mm x 508mm
Minimum Recommended Capacity	1000ml
Maximum Recommended Capacity	3500ml
Adjustable Temperature Range on Heater	20-50°C
Recommended Operating Ambient Temperature Range	10-35°C
Recommended Operating Relative Humidity Range	10-89%
Adjustable Timer Settings	0 - 59 minutes, 59 seconds or Continuous
No Load Paddle Speeds (@ nominal 20°C)	125rpm (±5%) LOW 150rpm (±5%) NORM. 175rpm (±5%) HIGH
Paddle Clearance	0-20mm

* Only these or equivalent UL-approved fuses should be used.

STOMACHER® 3500 Thermo
USER INSTRUCTIONS

8.3.2 EU and UK Products

Model	Sttomacher® 3500 Thermo
Cat No.	3500/002/EU and 3500/002/UK
Dimensions	480mm wide x 480mm deep x 520mm high (unpacked)
Weight	40kg (unpacked)
Supply Voltage	220-250V
Supply Frequency	50-60Hz
Plug Top Fuse	F5A (UK cord set only)
Mains Inlet Fuses*	T3.15A 250V 5x20mm, breaking capacity: 35A @250V
Motor Transformer Fuse*	T250mA 250V 5x20mm, breaking capacity 35A @ 250V
Heater Transformer Fuse*	T10A 250V 5x20mm, breaking capacity 100A @ 250V
PCB Fuse*	6.3A 250V HRC ceramic 5x20mm breaking capacity 100A @ 250V
Insulation	Class 1 (Earthed)
Installation	Over Voltage Category II
Pollution	Pollution Degree 2
Duty Cycle	Continuous
Rated Load	420W (of which heater is 300W)
Disposable Bag Size	380mm x 508mm
Minimum Recommended Capacity	1000ml
Maximum Recommended Capacity	3500ml
Adjustable Temperature Range on Heater	20-50°C
Recommended Operating Ambient Temperature Range	10-35°C
Recommended Operating Relative Humidity Range	10-89%
Adjustable Timer Settings	0 - 59 minutes, 59 seconds or Continuous
No Load Paddle Speeds (@ nominal 20°C)	125rpm (±5%) LOW 150rpm (±5%) NORM. 175rpm (±5%) HIGH
Paddle Clearance	0-20mm

* Only these or equivalent UL-approved fuses should be used

STOMACHER®
GEBRAUCHSANWEISUNG

9. MAINTENANCE

9.1 Cleaning

The instrument should be kept externally clean by wiping over periodically with a cloth damped with mild liquid detergent. **Do not** use any solvent-based cleaning agents, as they will damage the paint finish. First switch the instrument off and disconnect from the mains electrical supply before wiping down all the surfaces including the control panel.

CAUTION: - Ensure the equipment is switched **off** and unplugged from the mains electrical supply before cleaning near any electrical components.

To facilitate cleaning the processing chamber, the door hinge lugs are open-slotted to enable the door to be lifted from the lower pivot pins. To do this open the door in the normal way by lifting the lid fully upward and back then pull the door sharply upwards. In the *Stomacher® 3500, and 3500 Biowasher*, the black neoprene sheet should be removed first by unscrewing the knurled thumbscrews.

Note that the door **must not** be removed on the Stomacher 3500 Thermo except by a qualified technician as the procedure is more involved due to the electrical connections to the heater blanket, however the neoprene sheet can be removed to assist cleaning.

A small handled brush may be helpful for cleaning. It is recommended this procedure be carried out immediately in the event of any spillage. Refitting of the door is the reversal of the above procedure; ensure the door hinge lugs are fully engaged on both sides before commencing use.

9.2 Replacing Primary Fuses

The primary fuses can only be removed with the aid of a tool, typically a screwdriver, since they are not considered operative replaceable. In the event of a fuse failure we recommend the equipment and mains electrical supply is checked by a competent qualified electrician.

WARNING: - When replacing fuses ensure they are replaced with fuses of the same rating and specification, refer to the appropriate model specification section of this manual. Please contact *Seward Technical Service* if in doubt.

9.3 Servicing and Spare Parts

Suitably qualified persons should only carry out internal servicing and maintenance. A Maintenance Manual is available giving full details of servicing and repair procedures, wiring diagrams, parts identification and general assembly drawings. We recommend as a matter of routine that the instrument is inspected and serviced at least every six months or sooner if extensively used.

CAUTION: - This equipment should **not** be used if damaged in any way. If in doubt please contact your local *Seward Ltd* authorised service centre.

STOMACHER®
USER INSTRUCTIONS

10. WARRANTY AND SERVICE POLICY

All *Seward Stomachers*® are protected by a 36-month warranty covering faulty workmanship and materials. In the event of a fault developing within this period please contact *Seward Customer Service* who will organise the collection/return of the instrument for warranty repair and/or replacement at Seward's discretion.

The warranty is void if the instrument has been damaged as a result of unauthorised service, modification or subject to neglect, misuse, and accident, improper installation or operation.

11. COMPLIANCE

Seward Stomachers® are designed and manufactured to conform to the following standards: -

- IEC 1010-1 : 1990 Safety Requirements for Electrical Equipment for Measurement, Control and Laboratory Use.
- UL 3101 - 1 : 1993 Electrical Equipment for Laboratory Use General Requirements
- This equipment complies with the essential requirements of the European Council Directive 89/336/EEC relating to EMC and carries the CE mark.
- This equipment complies with the requirements of UL and carries the UL mark. UL file #E168827.

12. STORAGE AND TRANSPORT

Recommended storage and transport conditions are:-

Ambient Temperature Range	-20 to + 50°C
Relative Humidity Range	10 - 90%

Seward Stomachers® should ideally be stored in a clean environment and for long periods of storage it should be re-packed in the original packaging.

Seward Stomachers® should be transported in the original packaging.