

CENTRÍFUGA DE BAJA VELOCIDAD HICAP+ (ROTOR 250 ML)
HICAP+ LOW SPEED CENTRIFUGE (250 ML ROTOR)
CENTRIFUGEUSE BASSE VITESSE HICAP+ (ROTOR 250 ML)

Modelo | Model | Modèle 2761



Este manual es parte inseparable del aparato por lo que debe estar disponible a todos los usuarios del equipo. Le recomendamos leer atentamente el presente manual y seguir rigurosamente los procedimientos de uso para obtener las máximas prestaciones y una mayor duración del mismo.

This manual should be available for all users of these equipments. To get the best results and a higher duration of this equipment it is advisable to read carefully this manual and follow the processes of use.

Ce manuel est une partie indissociable de l'appareil et doit être mis à la disposition de tous les utilisateurs de l'équipement. Nous vous recommandons de lire attentivement ce manuel et de suivre scrupuleusement les procédures d'utilisation afin d'obtenir des performances maximales et une plus longue durée de vie de l'appareil.

LANGUAGE INDEX

Spanish	1-22
English	23-43
French	44-64

DEVICE WORKING ENVIRONMENT



To ensure the safety of the machine, consider the following factors that may damage the centrifuge:

- Chemical effect.
- Environmental impacts, including natural ultraviolet radiation.
- Corrosion and wear of protective cover parts and other safety parts.
- Indoor use
- Altitude ≤ 2000 m
- The applicable ambient temperature range is $+ 5\text{ }^{\circ}\text{C} \sim + 40\text{ }^{\circ}\text{C}$
- The applicable relative humidity range is $\leq 80\%$
- Power supply AC220V, 50/60Hz, 10A
- Enough ventilation equipment must be installed in the room
- No vibration and airflow that affect the performance
- No conductive dust, explosive gases and corrosive gases in the surrounding air

SAFETY TIPS

- Before using this machine for the first time, please read this manual carefully.
- This centrifuge can only be operated by trained and authorized personnel.
- The repair of the equipment can only be completed by the authorized Technical Service.
- Never use the following materials in the centrifuge:
 - Inflammable and explosive materials
 - Strong chemical-action materials
 - Toxic or radioactive substances, or pathogenic microorganisms, etc.
- Only qualified maintenance personnel can perform maintenance operation on the centrifuge with appropriate tools.
- Use the accessories provided by the manufacturer. If the user wants to use other accessories, the company will not be responsible for the adverse consequences caused.
- This centrifuge must be inspected and maintained at specified time intervals.

DESCRIPTION OF THE SAFETY WARNING SIGNS



Note: Please read the instructions carefully before using the centrifuge!



Note: High voltage danger! Danger of electric shock!

THE MEANING OF THE SAFETY INSTRUCTIONS

In order to avoid damage to personnel, surrounding objects and environment, please observe all safety instructions in this user manual.

In addition to the recognized occupational rules on accident prevention, environmental protection and in terms of safety and occupation, the local laws and regulations of the country of the user of the centrifuge must be carefully observed.

CONSEQUENCES OF IGNORING THE SAFE OPERATING PROCEDURES

Any neglect of safety operating procedures, laws and regulations and various rules will lead to harm to personnel, objects and the environment.

TABLE OF CONTENTS

1. Safe terms of use	26
1.1 Precauciones de uso	27
2. Introduction to the 2761 low speed centrifuge.....	27
2.1 Apariencia	27
2.2 Panorama general.....	28
2.3 Introducción a la estructura del equipo.....	28
2.4 Seguridad y protección.....	29
2.5 Requisitos para la colocación de la máquina	29
3. Optional accessories.....	30
4. Preparation before use.....	31
4.1 Transporte e instalación.....	31
4.2 Seleccionar un lugar de ubicación razonable.....	31
4.3 Colocar la máquina firmemente	31
4.4 Conectar correctamente la fuente de alimentación.....	31
5. Operating instructions.....	32
5.1 Introducción al panel de control y la interfaz de visualización	32
5.2 Arranque.....	33
5.3 Apertura de la tapa.....	33
5.4 Cierre de la tapa	33
5.5 Instalación del rotor.....	33
5.6 Cálculo de la carga del rotor	34
5.7 Llenado de las muestras en recipientes centrífugos.....	35
5.8 Uso seguro del rotor.....	35
5.9 Ejemplo de configuración de parámetros.....	35
5.10 Configuración de otros parámetros	36
6. Maintenance	37
6.1 Limpieza y descontaminación	37
6.2 Mantenimiento.....	38
7. Fault treatment	39
7.1 Apertura de la tapa en caso de emergencia.....	39
7.2 Información sobre alarmas de fallos.....	39
8. Technical data	42
9. Packing list.....	43
10. Warranty.....	43

1. SAFE TERMS OF USE

The 2761 model centrifuge is based to current technical and safety standards:

- **IEC61010-1:2001** Safety Requirements for Electrical Equipment for Measurement and Control Laboratories - Part 1: General Safety Requirements.
- **IEC61010-2-020:2006** Safety Requirements for Electrical Equipment Used in Measurement and Control Laboratories. Special Requirements for Centrifuges Used in Laboratories.
- **ISO780-1997** Pictorial Marks for Packaging, Storage and Transportation.
- **ICS19.040** Transportation Test of Electronic Measuring Instruments.
- **IEC60601** Environmental Requirements and Test Methods for Medical Electrical Equipment.

With the following incorrect or inappropriate use methods, equipment damage or personal injury may occur:

- Centrifuge is not used according to the design requirements.
- User and maintenance personnel are not trained.
- User makes inappropriate changes to the design without authorization.
- User did not notice or understand the safe use rules.



Any personnel involved in the use or maintenance of the centrifuge must read and understand the use method and safe use rules in this manual.

In addition, to prevent accidents, the following rules must be strictly implemented:

This manual is one of the components of the “2761 Low Speed Centrifuge” and must be placed with the device for consultation by the operator.

This low-speed centrifuge is designed for use in clinical medicine, biology, chemistry, genetic engineering, immunology, etc. The density of the sample separated at the maximum speed shall not exceed $1.2\text{g} / \text{cm}^3$; when the density of the sample is greater than $1.2\text{g} / \text{cm}^3$, the maximum speed of the rotor must be reduced accordingly.

During the operation of the centrifuge, and within 30cm around the centrifuge, there shall be no operator or harmful dangerous substances, and no objects blocking the centrifuge vent.

Take in consideration the following:

- The design of the centrifuge is neither corrosion-proof nor explosion-proof, so the centrifuge cannot be used in the environment with corrosion and possible explosion.
- Never use the following materials in the centrifuge:
 - Flammable and explosive materials
 - Strong chemical-acting materials
 - Toxic or radioactive substances, or pathogenic microorganisms, etc.
- For the isolation of corrosive substances and easily pathogenic microbial cells, effective sealing measures should be taken in advance, and effective disinfection measures should be carried out in time after use. For details, see “Maintenance -disinfection matters”.
- Separation of corrosive substances will cause damage of the material inside the centrifuge or weaken the mechanical strength of the rotor, so when separating corrosive substances, they must be placed in a protective container.

1.1 Operation precautions

- Before the centrifuge operation, it must confirm the installation of suitable rotor and ensure firm installation.
- When the centrifuge is in the operation process (when the rotor is rotating) or in the stop process (but the rotor is still rotating), do not manually open the door and move the centrifuge.
- The parts used in 2761 centrifuge must be special parts provided by the manufacturer. For some general parts, such as plastic separation containers, must meet the requirements of the maximum speed of the rotor and maximum centrifugal force.
- Do not use the centrifuge or separate samples when the door is open.
- When moving the centrifuge to other place, first disconnect the power cord.
- The replacement of the mechanical parts and electronic devices of the centrifuge must be implemented by the relevant personnel designated by the company.
- Using the centrifuge, operators must choose the appropriate rotor load, and must not overload the rotor.
- Often check the rotor; if the rotor is found to have obvious corrosion traces or obvious damage, must stop using.
- After use for a period of time, maintenance should be strictly in accordance with the “cleaning and disinfection” regulations.

2. INTRODUCTION TO THE 2761 LOW SPEED CENTRIFUGE

2.1 Appearance

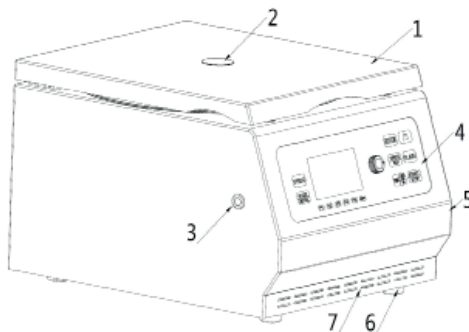

Figure 1: Front view

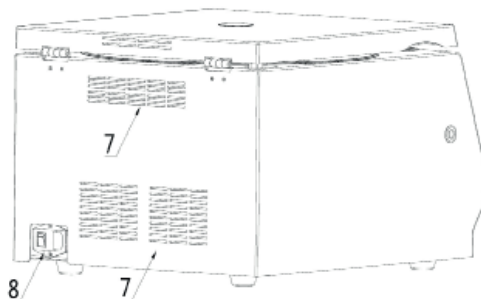

Figure 2: Rear view

Figures 1 and 2 illustrate:

1. Door cover
2. Observation window
3. Hole for emergency door opening
4. Control panel and display screen
5. Housing
6. Foot
7. Heat dissipation holes
8. Power socket and power switch



2.2 Overview

2761 model centrifuge is a low-speed centrifuge used for routine analysis in medical laboratories, biochemical and molecular biology research, and industrial laboratories. It can be widely used in clinical medicine, biology, chemistry, genetic engineering, immunology, and other fields. It is a standard device used for centrifugation and precipitation in laboratories. This machine can be used with 10 types of rotors (see Table 1: Rotor types and technical parameters).

2.3 Introduction to the equipment structure

This equipment consists of several systems, such as door cover system, chamber system, drive system, rotor system, base system, power supply system, control system, display system, and alarm system.

■ The door cover system includes door cover, door hinges, damping gas springs, door locks, door alarms, emergency door lock mechanisms, etc. The door hinges are located inside the rear of the rack, and the door lock is in front of the rack. Only when the door lock is locked can the centrifuge be started, otherwise the door alarm system will work (the buzzer will sound) and the machine will not start.

To open the door cover, simply press the opening key  on the machine control panel. When the door cover is opened to a certain height, the door hinge and damping gas spring can support the door cover. If there is a power outage or the door opening key  fails, and the sample must be taken out in a timely manner, it is necessary to use the supplied tool to insert it into the emergency door opening hole and rotate it clockwise until the door cover is opened (Figure 1).



When the rotor is rotating and the power is turned on, it is strictly prohibited to use the emergency tool to open the door cover!

■ The chamber system includes a stainless steel inner liner and a rubber sealing ring. The chamber system can provide a stable working environment.

■ This device uses a variable frequency motor to directly drive the rotor with the loaded sample to rotate together. The drive system adopts a direct drive method, which ensures high precision in matching the rotor with the shaft and smooth operation.

■ The rotor system is composed of various rotors (see Table 1: Rotor types and technical parameters), centrifuge tubes and other related accessories. The function of the rotor is to rotate the loaded sample at a certain speed, creating a relative centrifugal force field, thereby achieving the purpose of separating the sample. Since the centrifugal force reached when the rotor rotates at low speed is thousands of times more than the gravitational acceleration g value of the Earth, it is very important the safe use and careful maintenance of the rotor.

■ The base system consists of a frame, a base plate, a body shell, and rubber support feet.

■ The power supply system includes power sockets and switches, which are responsible for the supply of mains electricity required for the normal operation of the machine.

■ The control system includes settings for rotational speed and centrifugal force, operating time, selection of acceleration and deceleration levels, control of the entire machine display system, and alarm system. To ensure the normal operation of the machine and the personal safety of the operator, please do not disassemble the machine casually.

■ The display system consists of an LCD screen and a PET touch keyboard panel (control panel). It is a medium for human-machine dialogue. It can synchronously display various set parameters and track the actual changes of these parameters. In addition, it can also display alarms of various faults.

■ The alarm system is equipped with alarms for door cover failure, overspeed, imbalance, overvoltage, etc. When the machine experiences faults such as overspeed, door cover opening, or imbalance, the system will alarm. At this time, the buzzer will sound and the machine cannot function. The machine running will automatically stop until the fault is resolved. Note: To eliminate the alarm sound emitted by the buzzer, press the stop button on the control panel .

2.4 Safety and protection

The 2761 model centrifuge has a series of safety protection mechanisms:

■ The frame and protective ring are made of steel plate, and the internal chamber is made of stainless steel liner.

■ The door cover is made of an explosion-proof structure, and there is a locking mechanism at the front of the door cover. Only when the centrifuge is powered on and the rotor is stopped, you can press the opening button  on the control panel to open the centrifuge door cover. Only when the centrifuge door cover is locked can the centrifuge start working.

■ Speeding

When the operating speed of the centrifuge rotor exceeds the set speed by 400 rpm, the machine will sound an alarm. When the operating speed exceeds the maximum rated speed of the rotor by 450 rpm, the rotor will automatically stop running. The door can only be opened after the rotor has completely stopped. After troubleshooting, the machine will restart.

■ Imbalance

If the rotor rotates unevenly during operation, causing the shaft to shake beyond the specified range, the machine will stop running in a timely manner and issue an alarm prompt; generally, the rotor load is unbalanced. After the operation is terminated, open the door cover, and after troubleshooting, the operation can be restarted.

■ Door emergency opening

During the operation of the rotor, if there is a sudden power outage or machine malfunction, and the door cannot be opened by pressing the key, the door can be opened manually (see 2.3.1).

2.5 Machine placement requirements

■ This device should be placed on a level table with sufficient rigidity and away from vibration, avoiding direct exposure to heat sources and sunlight.

■ There should be a space of 10 cm to 15 cm on all sides of this machine for ventilation and heat dissipation.

■ After placement, the level should be adjusted and the four supporting feet at the bottom of the equipment should be evenly supported on the table.

■ The working power supply is 220VAC, 50/60Hz, 10A.



This machine must be strictly and reliably grounded. During the operation of the rotor, it is strictly prohibited to manually power off, otherwise it may cause damage to the control circuit.

3. OPTIONAL ACCESSORIES

A variety of rotors are available for use with 2761 model low speed centrifuge. You can purchase 2761 centrifuge according to your actual requirements (see “Table 1: Rotor types and technical parameters” for details).

Rotor (Auxilab code)	Capacity (mL × number of tubes)	Max. speed (rpm)	Max. relative centrifugal force (×g)	Tube type
6D-1 Hanging cup with biosafety lid (GNP020)	250 mL×4	4000	3040	PP, flat bottom with cover
6D-1.1 Tube hol-der (GNP013)	50 mL×8+15 mL× 8			PP, cone bottom with cover
6D-1.2 Tube hol-der (GNP021)	50 mL×8+5 mL (Vacutainer)×16			PP, cone bottom with cover / 13 × 100mm Vacutainer
6D-1.3 Tube hol-der (GNP022)	15 mL×28			PP, cone bottom with cover
6D-1.4 Tube hol-der (GNP023)	100 mL×4			PP, round bottom with cover
6D-1.5 Tube hol-der (GNP024)	5 mL (Vacutainer)×40			13×100mm Vacutainer
6D-4 Swing rotor (GNP032)	5 mL (Vacutainer)×64	4000	3050	13×100mm Vacu-tainer
6D-5 Angle rotor (GNM008)	15 mL×12	6000	5150	PP, round/conical bottom with cover
6D-6 Angle rotor (GNP034)	50 mL×8	6000	5150	PP, round/conical bottom with cover
6D-7 Microplate rotor (GNP035)	4 micropla- tes×2×96 2 deep-well plates×2×96	4000	2860	-

Other accessories:

GLK010: Adapter for 5 mL tubes (13x100 mm Vacutainer); to be used with rotor GNM008.

GLK011: Adapter for 8 mL tubes (16x100 mm Vacutainer); to be used with rotor GNM008.

GLK015: Adapter for 15 mL tubes; to be used with rotor GNP034.

4. PREPARATION BEFORE USE

4.1 Transport and installation

The centrifuge is transported using a packaging box, which contains buffer protection materials inside. After opening the packaging box, remove the buffer protection materials inside.



The net weight of the machine is about 53kg. When handling, it is necessary to lift the equipment from both sides and balance the force! Please handle vertically and do not shake the machine!

When transporting or transporting over long distances, please use specialized packaging boxes that are properly secured and maintained in a vertical position and should be handled with care.

4.2 Select a reasonable settlement site

This centrifuge can only be used indoors, and the location shall meet the following requirements:

- When the centrifuge is running, a safe distance of 20cm must be kept around, and hazardous substances shall not be placed within this safe distance, and personnel shall not stay.
- The support or table for the centrifuge shall be firm and not shaking or vibration. If movable support or trolley is used, a locking device shall be used to ensure the safe operation of the centrifuge.
- If the centrifuge is placed near the wall or in the corner, in order to ensure smooth air circulation and good heat dissipation, please ensure that the distance between the rear and the side of the centrifuge from the wall is not less than 10cm and 15cm, respectively.
- Centrifuge should be placed away from windows to avoid direct exposure to heat and sunlight.
- The four supporting feet should be evenly supported on the table and the level should be adjusted.
- The room for the centrifuge must be a constant temperature room with temperature between + 5°C and 40°C and a maximum ambient humidity of 80%. Keep the environment clean.

4.3 Position the machine firmly

Once the centrifuge is placed, do not move it at will. If you move it, re-confirm or adjust the level, and make the four supporting feet at the bottom of the machine be evenly supported on the table. Confirm that the support or table of the machine is firm and without vibrations.

4.4 Connect the power supply correctly

The power cord of the centrifuge should use a separate power socket, which must be well grounded. Confirm that the power cord used meets the safety specifications of the country and region where the centrifuge is located. The power voltage and frequency applicable to the centrifuge should meet the requirements specified in this manual or the specifications marked on the centrifuge nameplate. Please use the power cord provided with the machine, connect it correctly to the machine power socket, and connect it firmly to the network power supply. When the power switch is closed, it is “|”, and when the power switch is disconnected, it is “O”.

5. OPERATING INSTRUCTIONS

5.1 Introduction to control panel and display interface

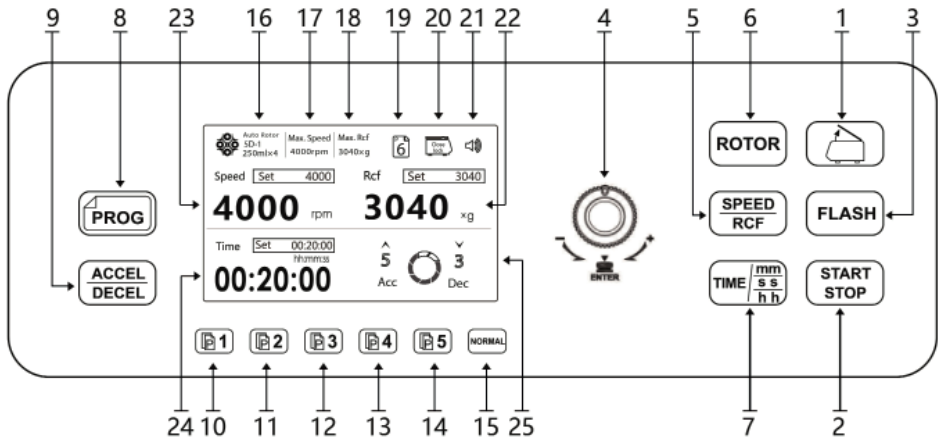



Figure 3: Schematic diagram of control panel/display interface

- | | |
|---|--|
| 1. Door opening key | 18. Maximum relative centrifugal force display area |
| 2. Start/Stop key | 19. Stored program opened or corresponding program number display area |
| 3. Short centrifugation key | 20. Door cover status display area |
| 4. Parameter adjustment knob | 21. Volume switch display area |
| 5. Speed/relative centrifugal force setting key (toggle key) | 22. Display area for set relative centrifugal force and real-time relative centrifugal force |
| 6. Rotor number setting key | 23. Display area for set speed and real-time speed |
| 7. Centrifugation time setting key (in hours/minutes/seconds) | 24. Display area for set centrifugation time and positive or negative counting |
| 8. Menu setting key | 25. Display area for acceleration/deceleration levels |
| 9. Acceleration/Deceleration setting key | |
| 10-14. Stored program shortcut call setting key | |
| 15. Press this key during non-program operation to instantly set various centrifugal parameters(NORMAL) | |
| 16. Rotor number display area | |
| 17. Maximum speed display area | |

5.2 Boot

Connect one end of the power cord that comes with the machine to the rear wall power socket, and the other end to the mains power supply. The mains power supply should use a separate socket. The power supply used in this machine is 220VAC, 50/60Hz. After connecting, turn on the power switch located on the right side of the rear of the machine. The buzzer gives a short sound, and the LCD display on the control panel lights up. After the self-inspection of the machine is completed, enter the Home screen, and now you can proceed to the next step.

5.3 Opening the door

Press the door opening key on the control panel once ; the door cover will automatically open and bounce to a certain height under the action of the damping gas spring. Then, it needs to be lifted up by hand to fully open the door cover, and the inner chamber will be presented to the user.

If a malfunction occurs and the door cover cannot be automatically opened, if it is necessary to remove the items inside the chamber, the manual door opening method can be used, as detailed in "2.3.1".

5.4 Closing the door

Gently press the center of the front end of the door cover to close it. After the door cover is locked, the machine will sound a "Didi" prompt and the "Door Cover Status Display Symbol" on the display screen will light up the door cover closed status.



When closing, press the door cover appropriately and do not use excessive force to avoid damage to the locking hook.

5.5 Installing the rotor

The rotor used must be the original rotor of the centrifuge manufacturer. This manual indicates various rotor models from manufacturer (see "Table 1: Rotor types and technical parameters" for details).



The use of inappropriate rotors and centrifuge tubes can lead to poor centrifugation results and even damage to the centrifuge.

The steps for installing the rotor are as follows (as shown in Figure 4)

- Turn on the power switch and wait for the self-test to be completed.
- Press the door opening key , open the centrifuge door cover and confirm that the chamber is clean and free of foreign objects.
- Clean the surface of the motor shaft.
- As shown in Figure 4, prepare the rotor you want to use. Grasp the rotor with both hands, align the center hole of the rotor with the motor spindle, place it vertically and at the bottom of the conical surface of the spindle. Release both hands, press the rotor down with your hands again.
- Use the tool (special hexagonal key) to tighten the locking nut clockwise.

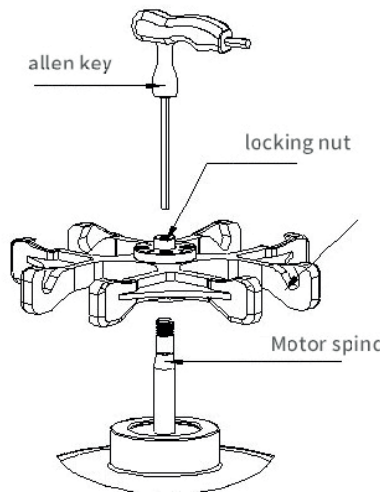

Figure 4: Schematic diagram of installing the rotor



After installing the rotor, check whether the installation position of the rotor has changed before each use or after a period of use. If necessary, tighten the locking nut again to ensure that the rotor is securely installed.

5.6 Calculation of rotor load

■ Calculation of maximum load capacity

When the centrifuge operates at low speed, there is a huge centrifugal force. When designing each rotor, it is required to have sufficient mechanical strength when working at the maximum rated speed - that is, should have a "Factor of safety"; however, this "Factor of safety" requires that the rotor load shall not exceed its maximum rated load.

If the total amount of sample exceeds the maximum rated load of the rotor, you must reduce the weight of the sample or calculate the allowable operating speed of the rotor (NPERM); ensure that the rotor load does not exceed its maximum rated load.

The calculation method for the allowable operating speed (NPERM) of the rotor is as follows:

$$NPERM = N_{max} \times (\text{maximum permissible load} \div \text{actual load})^{0.5}$$

N_{max} : Maximum rated speed



Do not overload the rotor, otherwise it may cause an explosion, and the debris generated can damage the centrifuge.

5.7 Filling samples in centrifugal containers

When the centrifuge is running, the better the rotor balance performance is, the better the centrifugation effect achieved. Therefore, the samples shall be filled into the centrifugal containers as evenly as possible, to achieve a better balance effect during operation. All samples must be placed in suitable containers.

Carefully check whether the container (centrifuge tube, etc) used complies with the maximum allowable rated acceleration (centrifugal force); if the requirement is met, please reduce the running speed for use, whenever possible.



Please pay attention to the service life of the centrifugal container used, especially when operating at the maximum allowable load and speed. Centrifugal containers used should be checked for damage and replaced in a timely manner.

5.8 Safe use of rotor

■ Before the rotor runs, the samples (centrifugal containers) should be accurately and symmetrically loaded.

■ The swing out rotor shall not operate for a long time in the 900rpm critical speed area, otherwise the machine will produce large vibration and affect the service life.



When the locking nut of the rotor is not tightened on the motor shaft, it is strictly prohibited to start the machine.



■ If the centrifuge needs to be operated repeatedly, the locking nut must be checked for looseness after several uses. If there is looseness, it must be tightened before starting up and running.

■ Centrifugal tubes must be symmetrically loaded (with a permissible weight error of $\leq 1.5g$). When loading samples asymmetrically, it is never allowed to start running.

5.9 Example of parameter setting

■ When the swing out rotor is used with 6D-1 hanging cup (250 mL \times 4), the specific operation is as follows: turn on the power - turn on the power switch of the device - the LCD display will light up. For example, the following parameters need to be set:

Rotor number	Speed (rpm)	Time (min)	Accel.	Decel.
6D-1	4000	20	5	3

■ **Set up**  : Press this key to cancel the memory operation and set various centrifugation parameters. At this time, the storage icon "P+number" on the display screen  will be hidden.

■ **Rotor number setting:** Press the  key on the control panel - Turn the parameter adjustment knob to set the rotor number to 6D-1.

■ **Speed setting:** Press the  key on the control panel - Flash the numbers in the Speed display area - Turn the parameter adjustment knob to set the speed to 4000.

Note: The Rcf value is automatically converted with the speed value.

■ **Time setting:** Press the  key on the control panel - Make the number in the time display area flash (2-digit time unit) - Turn the parameter adjustment knob to set the time to 20.



The selected parameter adjustment is as follows, the parameter adjustment knob can be pressed vertically downwards, or the system can automatically flash three times as the default.

ACCEL/DECEL setting (the acceleration and deceleration settings for starting the machine and to run the rotor to the set speed and stopping the machine from running, with values ranging from 0 to 9; the higher the value, the shorter the time it takes): Press the **ACCEL/DECEL** key on the control panel - turn the parameter adjustment knob to set the Acc value to 5. - Press the **ACCEL/DECEL** key again - turn the parameter adjustment knob to set the Dec value to 3.

Note: When Dec is set to 0, the stopping is free, and the system has no brake intervention.

After setting, display is as shown in the following figure:

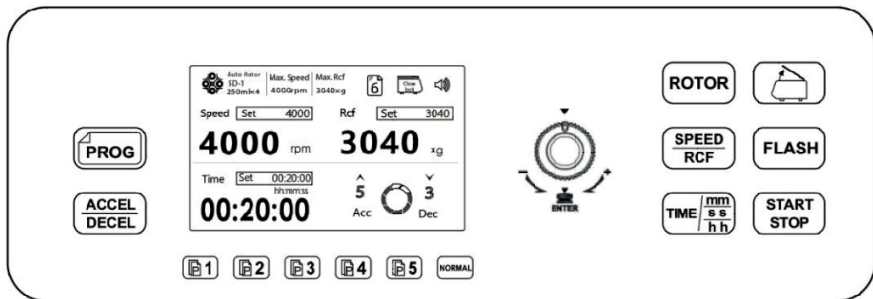

Figure 5: Example of parameter setting completed

5.10 Other parameters setting

■ **Relative centrifugal force setting:** Press the **SPEED RCF** key twice continuously on the control panel to make the number at Rcf area flash - turn the parameter adjustment knob to set its value.

Note: The speed value is automatically converted with the Rcf value.

■ During the process of parameter setting, if an alarm occurs due to machine malfunction or incorrect parameter setting, press the **START STOP** key to cancel the alarm and reset according to the rotor number.

■ Press the **START STOP** key, the machine starts running (if you need to stop midway, press the **START STOP** key). The time will gradually decrease from the set value to zero, and the centrifuge will automatically stop when the time value is displayed as zero; at this point, the speed will gradually decrease from the set value to zero (the time it takes for the speed to decrease from the set value to zero is related to deceleration setting). When the speed becomes zero, the door cover will automatically open, and the machine will emit shutdown sound. Press the **START STOP** key to stop the sound. Centrifugation completed.

■ **Short centrifugation:** Press and hold the **FLASH** key on the control panel. The speed will continue to increase, and when the key is released, it will stop. During this time, the maximum speed will be the set speed corresponding to the rotor number and time will increase in seconds.

■ **Reminder tone setting:** The user should hold down both the **SPEED RCF** and **TIME** keys for 3 seconds while in standby mode. Speed display in the display area Set:SonG, the numbers below flash, turn the adjustment knob to set the type of prompt tone, numbers 1-4 are the type of prompt tone, and 5 are the closing prompt tone (single system error and door opening/closing sound are still present).

■ **Storage memory settings:** The equipment provides 10 sets of custom memory programs for different experimental parameters. P1-P5 is a commonly used shortcut key on the control panel, and for P6-P10, please press the **PROG** key to enter. To cancel storage and switch to normal operation mode, press the **NORMAL** key.

■ After the machine speed stabilizes, if necessary, the parameters such as speed/centrifugal force, time, and acceleration/deceleration can be modified again. After resetting the parameters, there is no need to manually confirm, and the system will automatically flash three times to confirm the settings.

- Before setting parameters, the rotor must be correctly installed on the shaft.
- If an error is found during the parameter setting process, the parameters can be reset.

■ On the calculation of centrifugal force

The relative centrifugal force is generally thousands of times the gravity of Earth (g). It is a unit used to measure the efficiency of centrifuges in separating or precipitating objects. The calculation of centrifugal force is related to centrifugal speed and centrifugal radius, and is calculated according to the following equation:

$$RCF = 11.18 \times (n/1000)^2 \times r$$

r: Centrifugal radius in cm

n: Centrifugal speed in rpm

Note: The maximum centrifugal force value is related to the maximum centrifugal radius. The “centrifugal force value” set should take into account the radius of the rotor and the shape of the centrifugal container.

6. MAINTENANCE

6.1 Cleaning / decontamination

If dangerous substances spill or enter the equipment, the user is responsible for proper decontamination.



Users should clean according to the indications of this manual to ensure that the equipment is not damaged; the use of inappropriate cleaning agents and incorrect disinfection steps may cause damage to the centrifuge and internal components.

■ Implementation of cleaning / decontamination



Before cleaning and maintaining the centrifuge, please turn off the power switch and unplug the power cord.

The regular (or based on usage) cleaning and maintenance tasks mainly involve the centrifuge casing, inner chamber and rotor. This is to prevent pollutants from being left on surfaces, causing corrosion and pollution to the components used.



Organic solvents cannot be used as they can decompose the lubricating grease inside the motor bearings. During the cleaning process do not allow liquids, especially organic solvents, to come into contact with the motor spindle and bearing balls.

6.2 Maintenance

- Basic maintenance to be carried out by the user of the centrifuge:
 - Check that the rotor body and its components are in good condition. If you notice any damage, for safety reasons, do not continue working with them and consult the Technical Service.
 - Grease the swing out rotor brackets and check that the tube holders swing freely.
 - Check rubber parts.
 - Clean the centrifuge inside and out with non-abrasive products.
 - Check the power cable. If any damage is found, replace it immediately.
 - Ensure that ventilation openings are not obstructed and allow normal airflow.
- Do not use sharp objects that can collide with the rotor. During transportation and disassembly, it is necessary to prevent collisions and prevent cracks in the rotor due to scratches or external damages.
- Regularly inspect the rotor components (especially the bottom of the hanging cup/tube holder) for corrosion spots, grooves, and small cracks. If any of the above conditions are found, please stop using the rotor and contact your distributor.



When disassembling the rotor, grab it with both hands and lift it vertically without shaking it left or right.

- Normally, the rotor is cleaned once a week. If used for salt solutions or other corrosive samples, please clean it immediately after use. If the sample is found splashing, soaking, or dripping on the rotor during use, it should be locally cleaned immediately.
- When cleaning the rotor, please use neutral detergent to wet a sponge or cotton cloth, and then use distilled water to remove the detergent. Do not sprinkle or spray the rotor with water, as the liquid may be carried away and cause corrosion. Allow to dry upside down after cleaning.
- Use a cloth or tweezers to remove debris from the centrifuge chamber.
- The connecting parts of the motor shaft and rotor shaft hole should be coated with lubricating grease.
- Steps for motor shaft maintenance:
 - Turn on the power switch and wait for the self-check to complete.
 - Press the  key to open the centrifuge door cover.
 - Use the special tool provided with the machine to loosen the locking nut and take out the rotor. Note that the clockwise direction is for tightening the locking nut, and the counterclockwise direction is for loosening the locking nut.
 - Clean the conical surface of the motor shaft without leaving any dirt. Add an appropriate amount of lubricating oil or use lubricating paper.
- When disassembling the centrifuge, the power must be cut off first and the power cord connected to the back wall of the machine must be unplugged. It is not allowed to operate with electricity to prevent personnel from getting electric shock or damaging the machine. Note: This operation can only be carried out by specially trained maintenance personnel.
- Only use spare parts supplied by the manufacturer.
- Cut off the power supply when the centrifuge is not in use.
- Transportation and storage

During the transportation and storage, please pay attention to moisture-proof and shockproof measures, and do not lay the equipment horizontally or upside down.

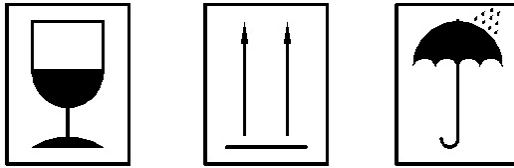

Figure 6: Precautions for transportation and storage

7. FAULT TREATMENT

7.1 Opening the door in emergency

During normal use, due to accidental power outage or failure of centrifuge functioning, you will not be able to use the automatic door opening function. In this case, you can use the manual door opening method to take out the samples.

Note: This method is only allowed to be used in emergency situations and should not be used casually.



When there is a power outage, the rotor stops running without braking function; it will take a long time to completely stop running; please be patient and wait.

The steps for emergency door opening are as follows:

- Confirm that the rotor has completely stopped.
- Turn off the power switch.
- Use the supplied tool, insert it into the emergency door opening and turn it clockwise until the door cover is opened; then you can take out the samples from the centrifuge.

7.2 Fault alarm information

The following list shows the alarm information indicated by the centrifuge, the causes of related faults and solution methods, so you can eliminate the faults according to the prompts. If the user is still unable to eliminate the fault after trying or the indicated alarm information is not in the following list, the user should immediately contact the Technical Service.



After an abnormality occurs, the power should be turned off first and restarted after the fault is resolved.

Table 3: Fault alarm information

Fault code	Meaning	Troubleshooting
Error 1	Imbalance	<ol style="list-style-type: none"> Place the samples in balance, with an allowable imbalance of $\leq 1.5\text{g}$. Check whether the two ends of the output line of the imbalance protection switch are short circuited and closed (under normal circumstances, it should be in an open circuit state). Contact the dealer to replace accessories.
Error 2	Speeding	<ol style="list-style-type: none"> Microcomputer control failure, contact the dealer. Check if the speed measuring line is too close to strong alternating current.
Error 3	Door cover not closed	<ol style="list-style-type: none"> Check if the door cover signal wiring is properly plugged in. Check if there is an open circuit at both ends of the lead wire of the door cover detection switch (it should be in a short circuit closed state under normal door cover closure). Check if the manual switch of the door lock is smooth and if there is a mechanical fault, replace the parts.
Error 4	Motor Hall sensor failure	Contact the dealer to replace the motor.
Error 5	Brake overpressure	<ol style="list-style-type: none"> Check if the brake resistor is properly connected or if the brake resistor is burnt out. Reduce the DEC value.
Error 6	Overcurrent	<ol style="list-style-type: none"> Accelerate too quickly under heavy load, reduce the ACC value. Drive board failure or high external power supply voltage. Motor failure.
Error 7	No speed measurement	<ol style="list-style-type: none"> Check the speed measuring cable to ensure that it is connected properly. The motor speed measuring Hall sensor is faulty, and the speed measuring plate at the end of the motor needs to be replaced. The motor is malfunctioning and cannot operate normally. It is necessary to replace the motor shaft. The control board (display board) is faulty and unable to measure speed. The control board needs to be replaced. The drive board is faulty and cannot drive the motor. The drive board needs to be replaced.
Error 8	Communication error	<ol style="list-style-type: none"> Check if the communication cable (10 pins grey flat cable) is connected properly. The drive board is faulty and needs to be replaced.
Error 9	Overvoltage	Ensure that the voltage supply of the external power grid meets the rated voltage of the machine.
Error 10	Door opening fault	The door opening is not in place or the door opening limit switch is faulty.

Code	Meaning	Troubleshooting
Error 11	Door closing fault	Door closing is not in place or door closing limit switch failure.
Error 13	Damaged lock in place	Contact the dealer.
Error 15	The set speed cannot be reached	Contact the dealer.

Table 4: Failures, causes and troubleshooting

Failure	Failure causes and troubleshooting
Display off or suddenly the display turns off	<ol style="list-style-type: none"> 1. Check whether the power socket and the connection are good, and whether the power socket is charged. 2. Check whether the power switch has no good contact. 3. Check the fuse. If it is blown, please replace the fuse. 4. If the cause cannot be found, please contact the Technical Service.
Sudden stop during operation	<ol style="list-style-type: none"> 1. The speed is over the maximum rated speed of the rotor. 2. Once the rotor exceeds the max. rated speed of the rotor by more than 450 rpm, the overspeed alarm will work immediately. At this time, the speed must be reset after the shutdown. 3. The speed is over the set speed. 4. When the motor is overheated, the power is cut off inside the machine and the machine stops running. 5. If the keyboard panel does not work, please check the power supply system of the machine. 6. The voltage may be too low; check whether the power supply voltage meets the requirements.
The door can't be opened	<ol style="list-style-type: none"> 1. Rotor has not stopped completely; the door should not be opened. 2. Check the door lock components. 3. Check the electrical wiring of the door lock. 4. Open the door by manual method. 5. If the cause cannot be found, please contact the Technical Service.
The machine vibrates greatly	<ol style="list-style-type: none"> 1. The rotor over the critical speed, some machine vibration is normal. 2. Check whether the rotor is locked. 3. Check the symmetry of the rotor load and check the level of the machine. 4. Check whether the rotor is properly installed. 5. Check the drive shaft and rotate by hand. If it cannot rotate smoothly, there may be a problem with the drive shaft or motor.
The display shows an exception	May be caused by the power grid interference; please shut down, to stop for one minute before the boot; the display can be normal again.
The motor does not rotate after pressing the start button	The electrical control circuit is broken; replace the electrical control board.
The machine smells burnt	<ol style="list-style-type: none"> 1. Cut off the power supply. 2. Check whether the motor is burned down. 3. Check whether the electrical components are burned down.

8. TECHNICAL DATA

Function/Parameter	Technical data
Operating environment	<ul style="list-style-type: none"> - Indoor use only - There is no vibration and airflow affecting the centrifuge performance. There is no conductive dust, explosive gas and corrosive gas in the surrounding air. - Altitude: ≤ 2000 m - Relative humidity: $\leq 80\%$ - Ambient temperature: $+5^{\circ}\text{C} - 40^{\circ}\text{C}$
Power supply	220VAC, 50/60Hz, 10A
Display screen	5-inch IPS color LCD display, resolution 800×480 dpi
Set time range	1-99 hours/1-59 minutes/1-59 seconds. Three modes are available for se-lection. Accuracy ± 1 second.
Maximum speed	6000rpm
Maximum RCF	$5150 \times g$
Maximum capacity	1000ml (250 mL x 4)
Acceleration	Speed up time from zero to maximum speed ≤ 2 minutes
Deceleration	Time to decelerate from maximum speed to zero ≤ 3 minutes
Motor	Maintenance-free brushless DC variable frequency motor
Noise (at max. speed)	≤ 65 dB(A)
Size	450 mm (L)* 550 mm (W)* 340 mm (H)
Weight (without rotor)	53 Kg
Interference sup-pression standards	EN 61010-1, EN 61010-2-020, EN 61326-1, EN 61010-3-2/A2

9. PACKING LIST

N°.	Name	Quantity	Notes
1	2761 model centrifuge	1	
2	Power cord	1	
3	Rotor	1	According to the order
4	Special hexagonal key	1	
5	Lubricating grease	1	
6	User Manual	1	

10. WARRANTY

AUXILAB S.L. guarantees this centrifuge against manufacturing defects for a period of 24 months from the date of purchase, under the following assumptions:

- It covers any manufacturing defect, including the labour necessary to locate and change the defective parts at AUXILAB S.L. Technical Service.
- This warranty DOES NOT COVER breakdowns which, in the opinion of AUXILAB S.L. Technical Service, have been caused by incorrect installation, incorrect treatment, improper use or manipulation by personnel outside AUXILAB S.L. Technical Service.
- Spare parts with a limited life, such as fuses, batteries, etc., are not covered by the guarantee.
- Any device whose serial number has been removed or altered is considered out of warranty.
- It is expressly excluded any recognition of direct or indirect damages of any kind suffered by persons or things.