

MICROSCOPIOS DIGITALES ZUZI, SERIE 300
ZUZI DIGITAL MICROSCOPES, SERIES 300
MICROSCOPES DIGITAUX ZUZI, SÉRIE 300

MODELO - MODEL - MODÈLE 300NS-130, 300NS-500

Zuzi



Este manual es parte inseparable del aparato por lo que debe estar disponible a todos los usuarios del equipo. Le recomendamos leer atentamente el presente manual y seguir rigurosamente los procedimientos de uso para obtener las máximas prestaciones y una mayor duración del mismo.

This manual should be available for all users of these equipments. To get the best results and a higher duration of this equipment it is advisable to read carefully this manual and follow the processes of use.

Ce manuel est une partie indissociable de l'appareil et doit être mis à la disposition de tous les utilisateurs de l'équipement. Nous vous recommandons de lire attentivement ce manuel et de suivre scrupuleusement les procédures d'utilisation afin d'obtenir des performances maximales et une plus longue durée de vie de l'appareil.

LANGUAGE INDEX

Spanish	1-7
English	8-13
French	14-19

TABLE OF CONTENTS

1. APPLICATION.....	8
2. CONFIGURATION	9
3. SPECIFICATIONS	11
4. OPERATION	12
5. MAINTENANCE	13

1. APPLICATION

These microscopes are widely used for education in secondary schools and universities, in studies of Biology, Bacteriology, Histology, Pathology, etc.

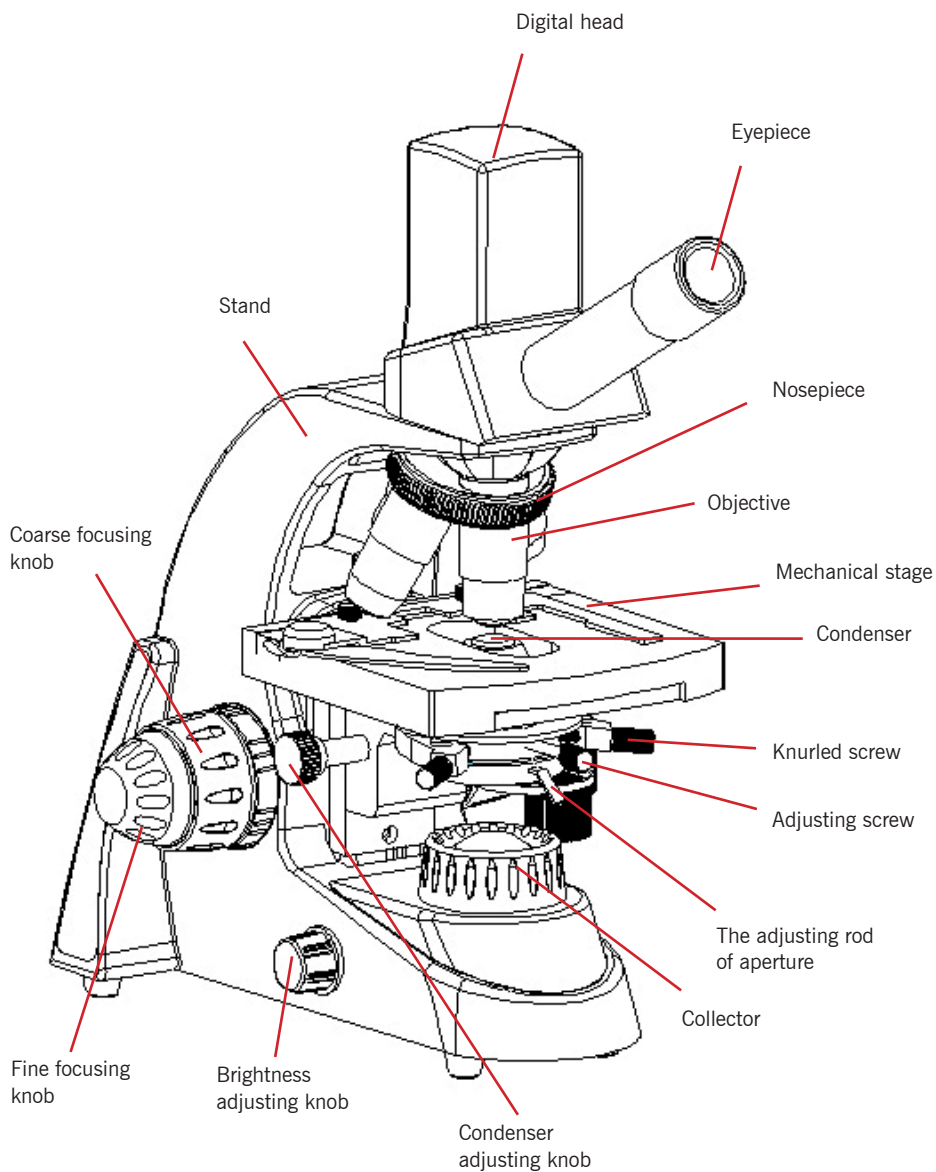
2. CONFIGURATION

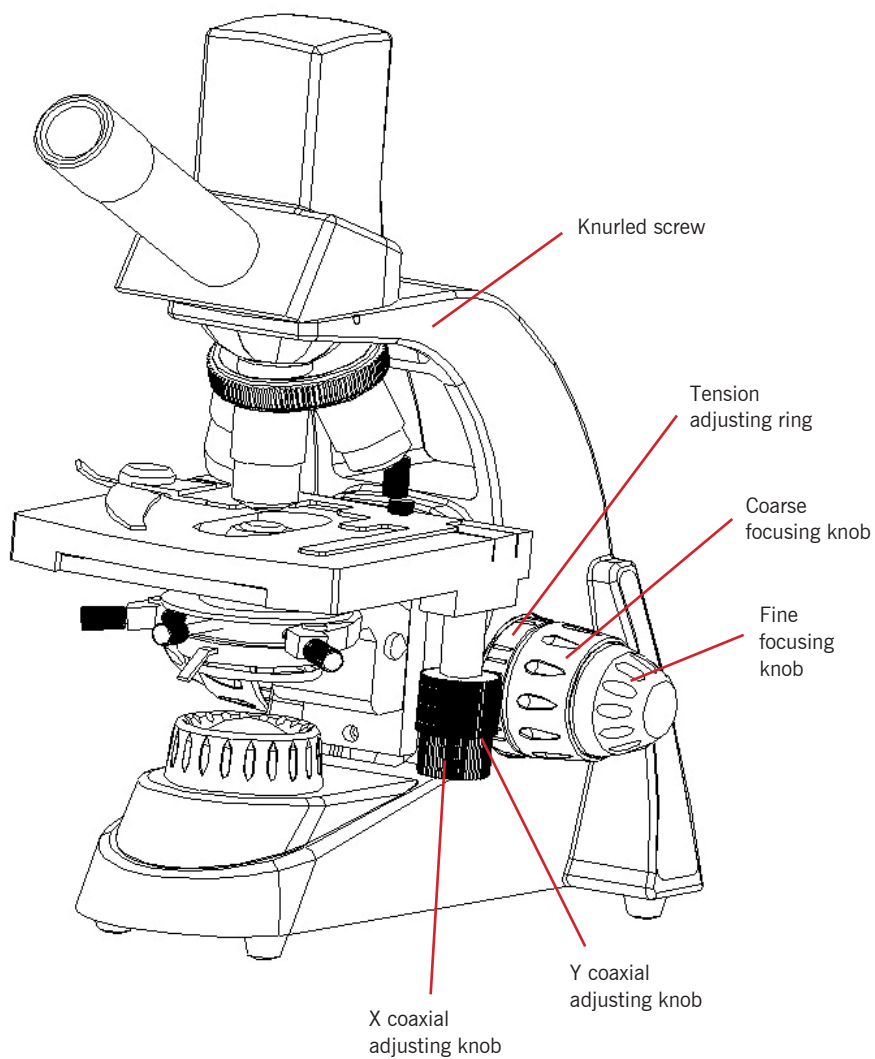

3. SPECIFICATIONS

Digital head	Model 300NS-130 (ref. HBB018): Monocular head, built-in CMOS camera, resolution 1280 x 1024 (1.3 MPixel), inclined at 38°, rotating 360° Model 300NS-500 (ref. HBB019): Monocular head, built-in CMOS camera, resolution 2560 x 1920 (5.0 MPixel), inclined at 38°, rotating 360°	
Eyepiece	WF10X (18mm)	
Nosepiece	Quadruple	
Objectives	Achromatic objectives: 4X, 10X, 40Xs, 100Xs (oil)	
Stage	Double layer mechanical stage Size: 110x125mm	
Condenser	Abbe condenser N.A. 1.25 with diaphragm and filter	
Focusing	Coaxial coarse and fine focusing adjustment with rack and pinion mechanism	
Light source	LED 1W	
Collector	High brightness	
Optional accessories	Eyepieces: WF16X, WF20X, WF25X	
	Objectives	Achromatic 20X, 60X
		SP achromatic 4X, 10X, 20X, 40X, 60X, 100X
		Plan achromatic 4X, 10X, 20X, 40X, 60X, 100X
Dark field condenser, phase contrast		

Objectives

Type	Magnification	Numerical aperture (N.A.)	Working distance (mm)	Thickness of the cover slip (mm)
Achromatic objectives	4X	0.1	29	0.17
	10X	0.25	5.8	0.17
	40Xs	0.65	0.63	0.17
	100Xs (oil)	1.25	0.23	0.17

4. OPERATION

1. Installation

- Carefully place the microscope on a stable work surface.
- Remove plastic bags and dustproof cover of each adapter.
- Put the head into the adapter of stand, tighten the fixing screw.
- Familiarize yourself the mechanical parts of microscope. Gently operate each part by hand to see how it behaves and what result it produces.
- Connect the power cable to the mains socket.

Notes:

- The microscope must be earthed.
- Make sure that the supply voltage matches the voltage indicated on the microscope label.

2. Using the instrument

- Turn on the power switch, turn the brightness adjusting knob to make the brightness 70% of the full load.
- Place the specimen (slide) to be viewed smoothly onto the stage, cover slip to face to the objective. Clamp specimen (slide) carefully with the movable spring clip.
- The magnitude of incident beam of light can be changed when adjusting the aperture diaphragm. The highest resolution of the objectives can be reached when the fitted aperture diaphragm is adjusted. When the objectives are changed, to get the best resolution of the objective, please take off the eyepiece to observe the size of aperture diaphragm in the eyepiece tube. It is better to adjust aperture diaphragm till it is a little smaller than the aperture of the objective.

Note: Aperture diaphragm is not for adjusting the brightness, the brightness is adjusted through brightness adjusting knob.

- Swing out the filter holder, according to user's needs put filter in the filter holder and then backtrack.
- Turn the nosepiece to change the objective and make sure the objective is shift in the light path until hear a click.
- When adjusting the focus, in order to prevent that objective touch the specimen, turn the coarse focusing knob until the specimen is approximately 3.2 mm from the objective. Slowly turn the coarse focusing knob until a clear image is obtained, then use the fine focusing knob to enhance the observation of the specimen to its clearest image. If the magnification is increased, you can obtain clear image with a little fine adjustment.
- When using objective 100X to observe, lift the condenser to the highest position, then drop a little cedar oil on surface of objective 100X and specimen (cover slip). If there's air bubble in oil, it will influence observation. Remove the air bubble by swinging nosepiece several times. The 100X oil immersion objective and specimen should be wiped off with a piece of soft, clean cloth or lens tissue to remove the cedar oil with xylene immediately after using.
- Turn transversal and longitudinal direction adjusting knobs located just below the stage, the specimen may be moved to the center of the eyepiece's viewing field for observation.
- Bulb and fuse replacement (the power cable must be disconnected).

1) Bulb replacement: Loosen the knurled screw on the underside of microscope and open the panel to expose the bulb. Remove the old bulb after it becomes cool (the bulb is very hot during use and immediately after use). Don't touch the new bulb with fingers, if there is a fingerprint and dirt, that will decrease the brightness and shorten the life of the bulb, wipe it with clean and soft cloth. Hold the new

bulb with the same specification with clean gloves or gauze and vertically insert the pins to the jack. Close the panel and tighten the knurled screw with hand.

2) Fuse replacement: Open the fuse holder with a flat-blade screwdriver in the direction of the arrow. Remove the old fuse and install a new fuse with the same specification. Replace fuse holder and screw in place.

5. MAINTENANCE

■ The microscope must be placed in where is shady, dry, clean and there are no acids, alkalis and steam in the environment. Don't let it expose under sun light directly.

■ Working environment: Indoor temperature: 0°C-40°C

Maximum relative humidity: 85%

■ The microscope has been calibrated and inspected strictly before leaving factory; the users must not knock down the instrument.

■ If there's dust on the lens, blow it by rubber ball blower, after that clean the lens gently with a soft brush. Carefully wipe off oil or fingerprints on the lens surface with lens tissue or absorbent cotton moistened with a few organic solvent (mixture of ether and alcohol 7:3).

■ Don't wipe the lens surface regularly, or else the lens will be scraped, reduce the quality of the transmission and imaging. Please keep the instrument clean.

■ Keep the mechanical parts clean and wipe regularly.

■ Shut off the power and pull out the plug when the microscope is not used, adjust the brightness knob to the minimum, cover the microscope with a dust cover.