

BOMBA DE INFUSIÓN VETERINARIA - EN-V5 VET
VETERINARY INFUSION PUMP - EN-V5 VET
POMPE À PERFUSION VÉTÉRINAIRE - EN-V5 VET

REF. - CODE - RÉF. - ZMZ021



Este manual es parte inseparable del aparato por lo que debe estar disponible a todos los usuarios del equipo. Le recomendamos leer atentamente el presente manual y seguir rigurosamente los procedimientos de uso para obtener las máximas prestaciones y una mayor duración del mismo.

This manual should be available for all users of these equipments. To get the best results and a higher duration of this equipment it is advisable to read carefully this manual and follow the processes of use.

Ce manuel est une partie indissociable de l'appareil et doit être mis à la disposition de tous les utilisateurs de l'équipement. Nous vous recommandons de lire attentivement ce manuel et de suivre scrupuleusement les procédures d'utilisation afin d'obtenir des performances maximales et une plus longue durée de vie de l'appareil.

LANGUAGE INDEX

Spanish	1-44
English	45-87
French	88-130

PREFACE1 Application Scope of the User Manual

This User Manual describes the product's most complete configuration, accessories and functions which may not exist in the product of the user, for more detailed information, please contact the provider.

2 Applicable Object of the User Manual

Applicable to professionally trained veterinary nurses, veterinary equipment repairers, etc.

3 Use Instructions

This User Manual covers the basic information on the safety and effectiveness of the product for guiding the operator to correctly install, test, operate, use and maintain the product. Please read this manual thoroughly before use and use the product in a correct way. Please carefully keep the User Manual for future use.

Our company is responsible for the reliability and performance of the equipment only all following conditions are met:

- Use the equipment according to this User Manual.
- The equipment can only be disassembled, assembled, replaced, tested, improved and repaired by the professional technicians of our company.
- All components and accessories as well as consumables for repair are provided by manufacturer.
- Relevant electric devices meet the international standard IEC/EN 60601-1 and this User Manual.

4 Paraphrase

【】 means mechanical button

『』 means touch button

() further Information

- means inapplicable

√ means accordant

→ means operation steps

Bolus: Infuse large volume of liquid in a short time.

KVO: Keep veins open, prevent blood back to the IV tube and needle blocked.

Anti-bolus: Motor automatically reverses while the IV tube with high pressure.

DPS: Used to indicate real-time detection and dynamic display of blocking pressure.

Warning /Attention: it may possibly cause physical injury or death if the cautions covered in the Warning are not obeyed.

Caution: it may possibly cause physical injury or property loss if the cautions are not obeyed.

Note: in case fails to follow the supplementary or prompt information on the operation instructions may possibly cause physical injury, the equipment fault or property loss if it is not obeyed.

Accessories: the optional components which are necessary and (or) suitable for using with the equipment to achieve the expected purpose, or provide convenience for achieving the expected purpose, or improve the expected purpose, or increase the additional functions of the equipment.

TABLE OF CONTENTS

Preface	45
1 Application Scope of the User Manual	45
2 Applicable Object of the User Manual	45
3 Use Instructions	45
4 Paraphrase	46
Chapter 1, Safety Instructions	50
1.1 Warnings	50
1.2 Cautions	51
1.3 Dialogue Window	52
1.4 Symbols	52
Chapter 2, Overview	54
2.1 Application Scope	54
2.1.1 Expected Purpose	54
2.1.2 Expected Working Environment	54
2.1.3 Suitable Objects	54
2.2 Contraindications	54
2.3 Working Principle	54
2.4 Structure and Performance	54
2.4.1 Structure and Performance	54
2.4.2 Functional Specifications	55
2.5 Product Specification	55
Chapter 3, Appearance	58
3.1 Front View	58
3.2 Operation Panel	59
3.3 Display screen	59
3.3.1 Title Bar	60
3.3.2 Interface icons description	60
3.4 Rear view	61
3.5 Drop Sensor (Optional)	61
Chapter 4, Installation	61
4.1 Unpacking and Checking	61
4.2 Installation	62
4.2.1 Install the infusion pump	62
4.2.2 Install the drop sensor	62
4.2.3 Heater installation	63
Chapter 5, Preparation and Precautions Before Use	63
5.1 Use Preparation	63
5.2 Operation Cautions	64

Chapter 6, Basic Operation	64
6.1 Operation Flow	64
6.2 Infusion Operation	64
6.2.1 Starting and SelfTest	64
6.2.2 Infusion Apparatus Installation	65
6.2.3 Replace Infusion Line/Infusion Container	66
6.2.4 Selecting the infusion set brand	66
6.2.5 Set infusion mode	66
6.2.6 Purge Air	67
6.2.7 Set the infusion parameters	67
6.2.8 Setting up heater function	67
6.2.9 Start infusion	67
6.2.10 Changing infusing parameters during infusion	68
6.2.11 Bolus	68
6.2.12 Infusion Completion	68
6.2.13 Stop Infusion	68
6.2.14 Remove IV set	68
6.2.15 Power off or Standby	68
Chapter 7, System Setting	69
7.1 Settings	69
7.1.1 Drug library	69
7.1.2 KVO rate	69
7.1.3 Bolus rate	69
7.1.4 Occlusion Pressure	69
7.1.5 Bubble detecting level	70
7.1.6 Cumulative Bubble	70
7.1.7 Finish Pre-Alarm	71
7.1.8 Reminder alarm	71
7.1.9 Weight unit	71
7.1.10 Pressure Unit	71
7.1.11 Micro Mode	71
7.1.12 Drop Sensor	72
7.1.13 Tube brand	72
7.2.14 Heater Calibration	72
7.2 General	72
7.2.1 Network	72
7.2.2 Sound	73
7.2.3 Date & Time	73
7.2.4 Screen Lock	73
7.2.5 Brightness	73
7.2.6 Night mode	74

7.2.7 Nurse call	74
7.2.8 Nurse call Alarm Level	74
7.2.9 Battery Capacity Display	74
7.3 Patient	74
7.3.1 Patient Information	74
7.4 Records	74
7.4.1 History entries	74
7.4.2 Last therapies	74
7.4.3 Export history records	75
7.5 System	75
7.5.1 Language	75
7.5.2 SN (Serial Number)	75
7.5.3 Version	75
7.6 Reset Total Volume	75
7.7 Electronic Memory Function	75
Chapter 8, Alarm Prompt and Troubleshooting	75
8.1 Introduction to Alarm Level	75
8.2 Multi-level Alarm Rules	76
8.3 Alarm Handle	77
8.4 Fault Analysis and Solution	77
Chapter 9, Maintenance	77
9.1 Cleaning, disinfecting and sterilizing	77
9.1.1 Cleaning	77
9.1.2 Disinfecting	78
9.2 Periodical maintenance	78
9.2.1 Check the Appearance	78
9.2.2 Performance Check	78
9.2.3 Maintenance Plan	78
9.3 Add new brand and Calibration	79
9.4 Repair	80
9.4.1 Normal Repair Process	80
9.4.2 Maintenance for Long Term Store	80
9.5 Equipment Components/Accessories	80
9.6 Production Date	81
9.7 Recycling	81
Chapter 10, Battery	81
10.1 Check the Battery Performance	81
10.2 Replaced the Battery	82
Chapter 11, Appendix	82
Appendix A Start Up Graphs and Trumpet Curves	82
Appendix B Occlusion Response Property	84
Appendix C Alarm and Solution	85

CHAPTER 1, SAFETY INSTRUCTIONS

1.1 Warnings



- Before using, please check the equipment, connecting wire and accessories to ensure that it can work normally and safely. If there's anything abnormal, immediately stop working and contact our after-sale service department. Additionally, the adhesion or intrusion of fluid/drug may possibly cause the equipment fault and malfunction. Therefore, please clean the equipment after use, and store it correctly.
- This equipment must be operated by trained professional medical care personnel.
- It is not allowed to put and use the equipment in the environment with anaesthetic and other inflammable or explosive articles to avoid fire or explosion.
- It is not allowed to store or use the equipment in the environment with active chemical gas (including gas for disinfecting) and moist environment since it may influence the inside components of the infusion pump and may possibly cause performance drop or damage of the inside components.
- The operator shall guarantee that the set infusion parameters of this equipment are the same as the medical advice before starting infusion.
- Please correctly install the infusion apparatus according to the infusion indication direction of this equipment, ensure that infusion tube smoothly and straightly cross the creep device. Otherwise, it may possibly suck blood from the animal or fails to reach the expected performance.
- Please do not only depend on information prompt during use, please periodically check it to avoid accident.
- Tightly fix this equipment on the infusion stand and ensure the stability of the infusion stand. Be careful when moving the infusion stand and this equipment to avoid the equipment dropping and infusion stand falling or knocking the surrounding objects.
- If the infusion tube is twisted, or the filter or needle is obstructed, or blood in the needle which may obstruct the infusion, the pressure in the infusion tube will rise. When removing such occlusion, it may possibly cause "bolus injection" (temporary excess infusion) to the animal. The correct method is to tightly hold or clamp the infusion tube near the puncturing position, then open the door to drop the pressure in the infusion tube. Then loosen the infusion tube, solve the reason of occlusion, and restart infusion. If infusion is restarted when the occlusion reason exists, then it may cause occlusion alarm persistently, and the pressure in the infusion tube may keep rising, and may break or cut off the infusion tube, or hurt the animal.
- This equipment injects fluid/drug through extruding the infusion tube, but it can't detect the leakage if the infusion line is cut off or broken. Therefore, please periodically check it to avoid above fault during the working period.
- During infusion, please periodically check the dripping state of the fluid and the fluid/drug in the intravenous infusion bag/container, to ensure the correct working during infusion. This equipment doesn't directly measure the quantity of infusion fluid; therefore, it is possible that this equipment can't detect the free infusion flow under the extremely special condition.
- This equipment has the occlusion detection function for detecting and alarming when the infusion needle deviates the position in the vein, or the needle is not correctly punctured in the vein. However, it only alarms when the occlusion pressure has reached certain numerical value, and the puncturing part may possibly have become reddish, swelling or bleeding, additionally, it is possible that the device doesn't alarm for a long period if the actual occlusion pressure is lower than the alarm threshold value, therefore, please periodically check the puncturing part. If there's any abnormal phenomenon for the puncturing part, please timely take suitable measures, such as puncturing again.
- Only those infusion apparatus, line, infusion needle and other medical components that meet the local laws and regulations and the requirements covered in, and this User Manual can be adopted, it is suggested to adopt the infusion apparatus with same brand as this equipment. It can't ensure the infusion

accuracy if the unsuitable infusion line is adopted.

- It is not allowed to disassemble or refit this equipment or use it for other purposes except normal infusion.
- No one is allowed to repair this equipment except our company or the authorized repair technician of our company.
- Maintenance or replacement of spare parts is prohibited during the clinical use of the equipment.
- To avoid risk of electric shock, this equipment must only be connected to AC with Ground Protection.

1.2 Cautions



- Before its first use after purchase, or this equipment is not used for a long period, please charge the equipment with AC power supply. If it is not fully charged, under power failure, the equipment can't continue working with built-in battery power supply.
- This equipment cannot be used in places with radiological installation or magnetic resonance equipment as well as the places with high pressure oxygen therapy.
- Not to position ME Equipment to make it difficult to operate the disconnection device.
- The DC power supply is only suitable for applications where a backup power supply is required. Only use the DC power supply line provided by the manufacturer.
- Other devices near this equipment must meet corresponding EMC requirements, otherwise, it may influence the performance of this equipment.
- Under general conditions, please use AC power supply as much as possible since it can prolong the service life of the battery to a certain degree. When using AC power supply, ensure that the grounding wire is reliably connected with the ground, and only the AC power wire attached with this equipment shall be adopted. The built-in battery can only be used as the assistant power supply when the AC power supply can't reliably connected with the ground and is not under normal conditions (power failure or moving infusion).
- Before connecting this equipment with power supply, please keep the power socket and plug dry, and the power voltage and frequency meet the requirements listed in the equipment label or this User Manual.
- The equipment is equipped with the audible and visual alarm system, and the red and yellow alarm indicators will light on in turn to check if the alarm system can work normally, and the speaker makes the "beep" sound.
- Please keep the equipment away from the AC power socket for a certain distance to avoid fluid/drug splashing or dropping in the socket, otherwise, it may possibly cause short circuit.
- Please use the fluid/drug after it has reached or nearly reached room temperature. When the fluid/drug is used at low temperature, the air which is dissolved in the fluid/drug may cause more air bubbles and result in frequent air bubble alarm.
- It is not allowed to press and operate the button with sharp object (such as pencil tip and nail), otherwise, it may possibly cause early damage to button or surface film.
- Please do not use the infusion tube for 8h at the same pumping position. Infusion tube may distort after using for a long time and cause flow rate error. It is suggested to replace the pumping position or directly replace the infusion tube every 8h.
- Please tightly close the flow rate adjuster of the infusion apparatus before taking out the infusion apparatus to avoid liquid leakage.
- Under the condition of low flow rate infusion, please pay special attention to occlusion. The lower the infusion flow rate, the longer the time of detecting occlusion, and it in turn may possibly cause a long-time infusion to stop during this period.
- If the equipment suffered from dropping or impacting, please immediately stop using it, and contact our after-sale service department, because the inside components of the equipment may be possibly damaged even the appearance is not damaged, and abnormality does not occur when working. It is recommended to use the accessories specified in this manual to ensure animal safety.

1.3 Dialogue Window

Dialogue window mainly content include operation select, operation confirm etc. tips information. For instance:

Figure1.3-1 Operation select information

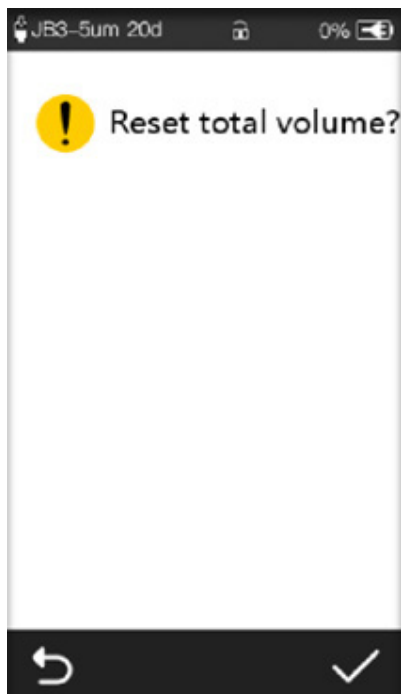
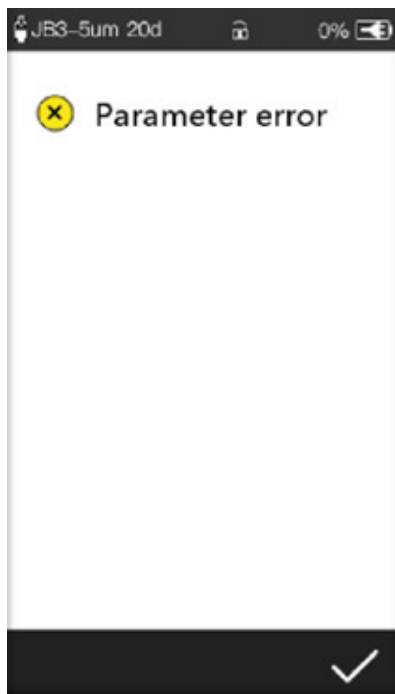























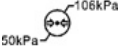

Figure 1.3-2Parameter error reminder



1.4 Symbols

Not all of the below symbols existed in the equipment you have purchased.

Marks	Description	Marks	Description
	Batch code		Protective earth (ground)
	Serial number	IP44	Dustproof and waterproof Prevent the pouring of solid objects larger than 1.0 mm in diameter and the intrusion of splashing water in all directions
	Caution		Both direct and alternating current
	Defibrillation-proof type CF applied Part		battery
	Date of Manufacture		Handle with harmless method
	environment-friendly use period (20 a)		Manufacturer
	Input / output		Non-ionizing electromagnetic radiation
	Unlock		Direct current
	Lock		This side up
	Keep dry		Fragile items
	Please refer to the instruction manual/manual		Stacking level limit
	Transportation package temperature limit range is -20-60 °C		The limited humidity range of transportation package is 10%-95%
	The environmental pressure of transportation package is limited to 50-106kPa		

CHAPTER 2, OVERVIEW

2.1 Application Scope

» 2.1.1 Expected Purpose

The infusion pump is used together with infusion set to control the dose of liquid infused into animal's body, for example intravenous infusion.

» 2.1.2 Expected Working Environment

Animal Hospital, Pet clinic.

» 2.1.3 Suitable Objects

Animal

2.2 Contraindications

No.

2.3 Working Principle

This equipment is a kind of instrument which can drive the pump to extrude the infusion tube for accurately control of the infusion drops or infusion flow rate with the motor and can guarantee to convey drug fluid safely in the vein of animal with even rate and accurate dosage.

2.4 Structure and Performance

» 2.4.1 Structure and Performance

The infusion pump is mainly composed of a control system, a motor driving unit, a peristaltic pressing mechanism, a detecting device, an alarm device, an input and display device, a housing, a supporting structure thereof and a software component. This equipment provides several infusion modes, such as ml/h mode, body weight mode, drip mode, sequence mode. Additionally, it also has functions such as history records, drug library, Anti-bolus, alarm and so on.

» 2.4.2 Functional Specifications

Function / Model		EN-V5 Vet
Infusion Mode	ml/h Mode	●
	Body-weight mode	●
	Drip mode	●
	Drug library mode	○
	Micro Mode	●
	Sequence Mode	●
Occlusion alarm level	5 Levels adjustable: Level 1:50mmHg Level 2:150mmHg Level 3:300mmHg Level 4:600mmHg Level 5:900mmHg	
Drug library	2000	
History entries	5000	
Brand Library	200	
WIFI	○	
Heater	●	

Remarks: ● means standard; ○ means optional.



This User Manual describes the most configuration and most complete functions, due to model difference or optional components, not all functions are equipped in the product you purchased.

2.5 Product Specification

Safety Classification	Electric protection Type	Class I
	Electric protection Level	Defibrillation proof type CF applied Part
	Protection against fluid ingress	IP44
	Working mode	Continuous operation
	Classification	Portable equipment, non-portable infusion pump
Specification Parameters	Infusion apparatus specification	10-60 drips/ml
	Infusion Rate	10-20 drips/ml specification infusion apparatus: 0.1-2000ml/h 21-40 drips/ml specification infusion apparatus: 0.1-800ml/h 41-60 drips/ml specification infusion apparatus: 0.1-400ml/h minimum step is 0.01ml/h <100ml/h step is 0.01ml/h, <1000ml/h step is 0.1ml/h, ≥1000ml/h step is 1ml/h
	Infusion accuracy	≤±5%

Specification Parameters	Drop rate	Infusion set drip pot setting range 10—60 drips/ml, drip rate 1- 2000 drops/min, step is 1 drops/min
	Drop rate accuracy	$\leq \pm 5\%$
	Bolus Rate (Bolus)	10-20 drips/ml specification infusion apparatus: 1-2000ml/h 21-40 drips/ml specification infusion apparatus: 1-800ml/h 41-60 drips/ml specification infusion apparatus:1-400ml/h minimum step is 0.01ml/h <100ml/h step is 0.01ml/h, <1000ml/h step is 0.1ml/h, ≥ 1000 ml/h step is 1ml/h
	Bolus Volume	0,1ml--50ml.
	Bolus Rate accuracy	$\leq \pm 10\%$
	Purge rate	10-20 drips/ml specification infusion apparatus: 100-2000ml/h 21-40 drips/ml specification infusion apparatus:100-800ml/h 41-60 drips/ml specification infusion apparatus: 100-400ml/h minimum step is 0.1ml/h <1000ml/h step is 0.1ml/h, ≥ 1000 ml/h step is 1ml/h
	Purge rate accuracy	$\leq \pm 5\%$
	VTBI	0-9999.99ml, minimum step is 0.01ml
	Total Volume Infused	0-9999.99ml
	KVO rate	0-5ml/h, minimum step is 0.01ml/h
	KVO rate accuracy	$\leq \pm 10\%$
	Micro mode setting range	0,1-200 ml/h
	Time Range	1s-99h59min59s
	Acti agentia	0.01-99999
	Volume	0,01-9999 ml
	Conc.	0.01-99999
	Dose rate	0.01-9999
	Cumulative Bubble	50 1000 μ l /15 min
	Heating range	(30.0-40.0) $^{\circ}$ C,The temperature step is 0.1 $^{\circ}$ C (default temperature is 37 $^{\circ}$ C), and the temperature accuracy is $\leq \pm 1^{\circ}$ C
	Heating efficiency	Infusion rate ≤ 100 mL/h, within 4 minutes reach to the target temperature, accuracy: $\leq \pm 1^{\circ}$ C. Infusion rate >100mL/h and ≤ 400 mL/h, within 10 minutes reach to the target temperature, accuracy: $\leq \pm 1^{\circ}$ C

Specification Parameters	Single fault bolus Volume	≤2ml
	Anti-bolus volume	≤0,2ml
	Fuse Type	MTS T2A 250V
	Dimensions	131.5x90x138mm (No fastening clamp, no drop sensor hook)
	Weight	≤1,55kg
Power Supply	AC power supply	Without heater: 100V-240V~, 50Hz/60Hz, 0.25A-0.10A. With heater: 100V-240V~, 50Hz/60Hz, 0.65A-0.35A
	Input power	Without heater: 50VA With heater: 100VA
	DC power supply	CC 10V-16V,1,5A-0,94A
Battery	Battery quantity	2 pieces
	Battery type	lithium battery
	Rated battery voltage	7.4 V
	Battery capacity	5200mAh
	Charging time	≤8h
	Running time	Use a new battery full of electricity to power: Running at 25 ml/h, the running time from start-up to exhaustion of alarm batteries is not less than 10 hours. Running at 2000 ml/h, the running time from start-up to exhaustion of alarm batteries is not less than 5 hours.
Alarm	Alarm signal sound pressure level	When the sound is set at lowest level, alarm signal sound pressure level ≥50dB(A) When the sound is set at highest level, alarm signal sound pressure level ≤80dB(A)
	Alarm information	High alarm : VTBI infused, Pressure high, Battery empty, system error, KVO finished, drop error, Dropper empty bottle, Single bubble, Cumulative Bubble, Door Open, Drug dose limits exceeded, Temperature high : Backup battery power exhaustion. Middle alarm: Reminder alarm, Battery nearly empty, VTBI near end, Standby time expired, Occlusion pre-alarm, Drop in pressure, Heater failure, Temperature low. Low alarm: No power supply, drop sensor connection, no heater installed.

Environment	Non-AP/APG type equipment	Do not use it in the environment with inflammable anesthetic gas mixed with air, and inflammable anesthetic gas mixed with oxygen or nitrous oxide
	Operating	(1) temperature: 5-40 °C (2) humidity: 15-95%, non-condensable (3) atmospheric pressure: 57-106kPa
	Transport & Storage	(1) temperature: -20-60 °C (2) humidity: 10-95%, non-condensable (3) atmospheric pressure: 50-106kPa

CHAPTER 3, APPEARANCE

3.1 Front View

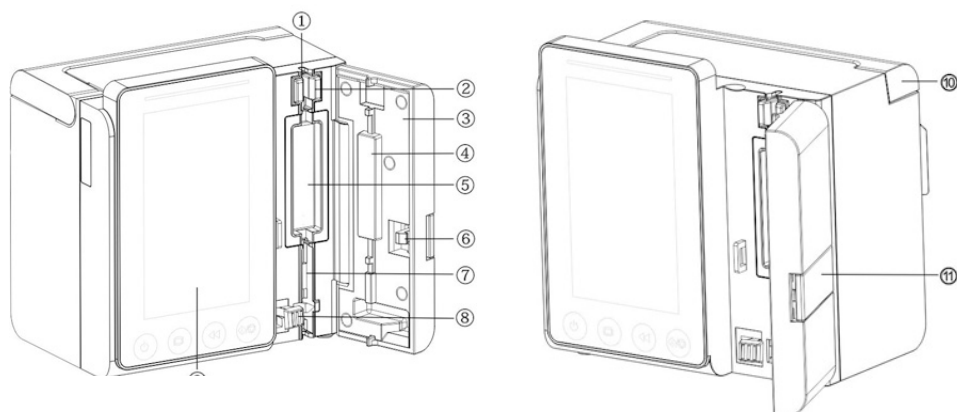

- 1 Tubing guide
- 2 Air-in-line sensor (Detection of bubbles in infusion pipelines)
- 3 Pump door
- 4 Pressure plate
- 5 Waterproof film
- 6 Door holder
- 7 Pressure sensor-DOWNSTREAM
- 8 Anti-free flow clamp
- 9 Display screen
- 10 Handle
- 11 Door switch



Note: It is recommended that the waterproof film be replaced once every two years. Contact the manufacturer or authorized dealer immediately for replacement if found damaged.

3.2 Operation Panel

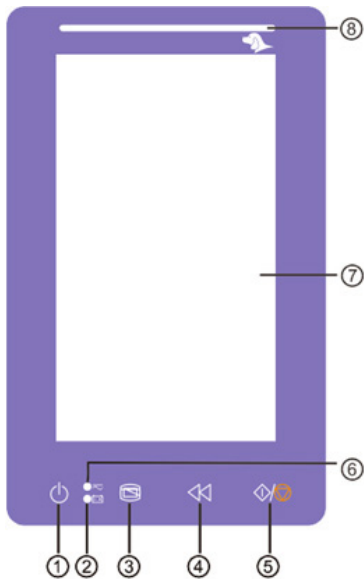

- 1 Power
Pump power switch, press and hold, pump power off. Stand-by selection button. Long press the power button until the screen closes and the pump shuts down.
- 2 Battery indicator(green)
Indicator flashing: device on, battery charging/power supply Indicator lights on: the battery is full of electricity. Indicator lights off: equipment shut down, no batteries
- 3 Menu
Enter system home page.
- 4 Bolus/Purge
- 5 Start/Stop
- 6 AC/DC indicator green
Turn on:Connect AC/DC power supply
Turn off: dis-connect AC/DC power supply
- 7 4.3 inches TFT(LCD) touch screen
- 8 Alarm indicator (red/yellow)
While pump alarms, indicator light glitters, with different frequency and color, more information please refer to Chapter 8.1.

3.3 Display screen



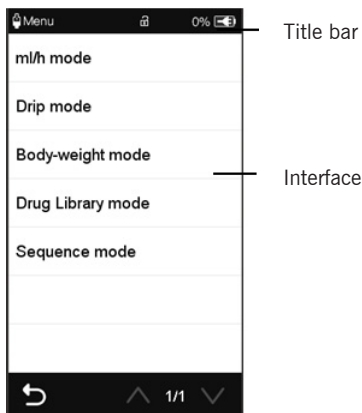



The display screen interface layout consists of title bar and typical interface.













» 3.3.1 Title Bar

Title bar displays real-time state information and is not touchable, the left upper corner displays the name of current editing parameter

Table 3.3.1-1

Icon	Paraphrase	Description
	Infusion apparatus indication icon	Infusion apparatus indication icon
	Lock screen indication icon	Unlock state icon is 
	Battery charging indication icon	Display the current battery charging state
	WIFI indication icon	Indicate WIFI connection state.
	Battery status indication icon	The percentage numerical or remaining time value at the left side of the icon displays the remaining battery. Since the remained battery may change, it may possibly show the following states: 

» 3.3.2 Interface icons description.

Icon	Paraphrase	Description
X/Y	Page indication	Arabic numerals mean, X is the current page, Y is the total page
	Up	Click this icon, return to the back page
	Down	Click this icon to enter the next page
	Return/Cancel	Click this icon, return to the back menu
	radio button-1	The current parameters is selected
	radio button-2	The current Level is selected
	Confirm	Click to save the input parameters or the selected parameters and exit
	ON	Mean this function is ON
	OFF	Mean this function is OFF.
	Clear button	Click it to clear input
	Backspace button	Click it to backspace delete
	toggle key	click to switch into English or case input setting

3.4 Rear view

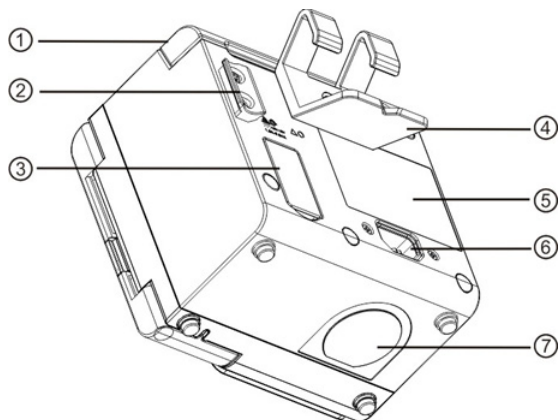

- 1 Handle
 2 Drop sensor bracket
 3 DB15 Multi-functional interface, with following functions
 - DC power input interface
 - Software uploading interface
 - Nurse call interface
 - Drop sensor interface
 - History record export
 - Heater interface
 Note: The above functions cannot be used at the same time.
 4 Clamp
 5 Product label
 6 AC/DC Adapter Port
 7 Loudspeaker

3.5 Drop Sensor (Optional)

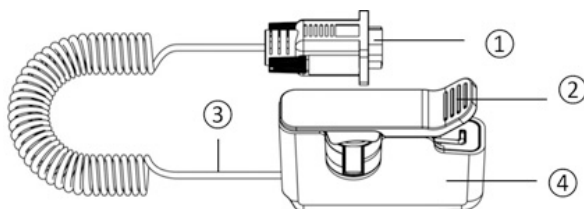

- 1 Plug(Connected to the device's drop sensor interface)
 2 Drop Pot Holder(Press down to adjust the spacing, let go of the drop pot Holder and it will automatically return to position)
 3 Cable
 4 Shell

CHAPTER 4, INSTALLATION

4.1 Unpacking and Checking

1. Please check the appearance before unpacking, if broken, please contact the transportation company or our after-sale service department quickly.
2. Please carefully open the package to avoid damaging the equipment and relevant accessories.
3. After unpacking, please check the objects according to the packing list, if there're insufficient or damaged accessories, please contact our company as soon as possible.
4. Please keep the relevant accessories, User Manual
5. Please keep the packing case and packing materials for future transportation or storage.



Warning: please put the packing materials out of reach of children. Please obey local laws and regulations or the hospital waste treatment system to handle the packing materials.

4.2 Installation

Warning: 

- This equipment shall be installed by designated technicians.
- When connecting this equipment with other electric devices to form the combination with special function, if the combination can't be confirmed dangerous or not, please contact our company or the electric expert of hospital to ensure that the necessary safety of all devices in the combination won't be destroyed.
- This equipment must be used and stored in environment regulated by our company.



» 4.2.1 Install the infusion pump

As shown in the figure, the infusion pump can be hung against the animal cage by the fastening clip.



Note: ● Ensure the stability of the animal cage that is attached to the infusion pump. Be careful when moving the animal cage and this equipment to prevent the equipment from slipping or colliding with nearby objects

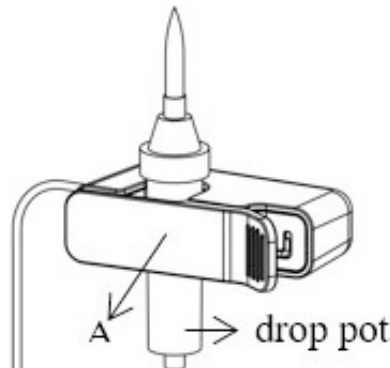

» 4.2.2 Install the drop sensor

Install steps:

Insert the drop sensor plug into the drop sensor port of this equipment and ensure tight connection.

After pushing the drop sensor slider to adjust the distance, clamp the drop sensor to the drop pot of the infusion set as shown in the figure, and the medicine drop position should not be lower than A.

Warning: 

- The fluid/drug volume in the murphy's dropper must be less than 1/3 of its volume.
- The drop sensor shall be vertical.
- The drop sensor should be perpendicular to the drop pot and higher than the liquid level.
- The drop sensor function uses infrared sensor technology. When the drop sensor function is turned on, the light-shielding pipeline is not applicable, otherwise the Drip Mode may fail.

» 4.2.3 Heater installation

The following are the heater installation steps:

1. Insert the plug of the silicone heater into the DB15 interface 1 of the infusion pump and tighten it;
2. Fix the heater to the silicone heater mounting seat 2;
3. Finally, put the infusion tubes output from the right card slot into the silicone heater tube slot 3.

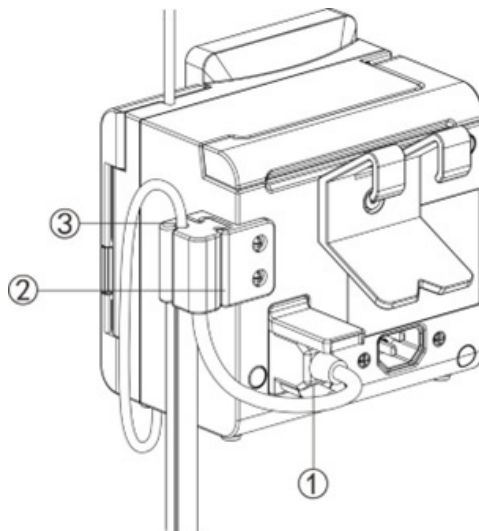
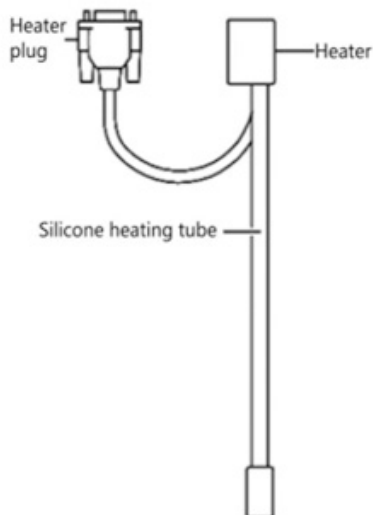

CHAPTER 5, PREPARATION AND PRECAUTIONS BEFORE USE

5.1 Use Preparation

The new equipment, or reusing after storing for a period, or reusing after repair, please check it to ensure before use:

- The equipment's appearance is clean and under good condition without cracks and leakage.
- The moving components are smooth and effective, for example: the pump door can be opened and closed smoothly, the button is effective.
- The touch screen can operate smoothly and effectively.
- The power cable is installed tightly and won't be easily damaged when pulling.
- Set and check the system time to ensure that the history records will be correctly recorded.
- In case only built-in battery is adopted for supplying power, please charge it to full before using, and ensure that the battery keeps at the effective working conditions.
- Carefully read the Warnings, Cautions and Operation Steps listed in this User Manual.

5.2 Operation Cautions

Cautions: 

- Avoid direct sunlight, high temperature or high humidity.
- The equipment shall be put at a position less than 1.2m to the height of the animal.
- The parameters can only be set or changed by the trained and professional personnel.
- Avoid the equipment working with fault to avoid medical negligence, which may hurt the health and even life of the animal.
- It may possibly drop the infusion accuracy or abnormal work of the equipment if the working environment temperature exceeds the designated range.
- The viscosity and specific gravity of infusion fluid will influence the infusion accuracy.

CHAPTER 6, BASIC OPERATION

6.1 Operation Flow

- Power on
- Install IV Set
- Select infusion tube brand or add new brand
- Select infusion mode
- Set Infusion Parameters
- Remove air bubble from the line
- Connect the infusion line with the animal
- Start infusion
- Infusion finish
- Remove the IV Set
- Power off or Standby

6.2 Infusion Operation

» 6.2.1 Starting and SelfTest

1. Press , power on the equipment.
2. After power on, the system will automatically check the motor, sensor, battery, memorizer, CPU communication, alarm indicator.
3. After the self-test is successful, the prompt interface: "New treatment" and "Last treatment". Select "New Treatment" to go directly to the ml/h mode setting interface. Select "Last treatment" to enter the last usage mode parameter setting interface.



Warning: If the self-test item does not pass, please contact the company and you are not allowed to continue using the equipment.

» 6.2.2 Infusion Apparatus Installation

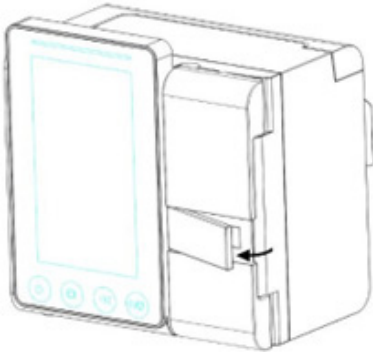

1. Open the pump door left and open it.

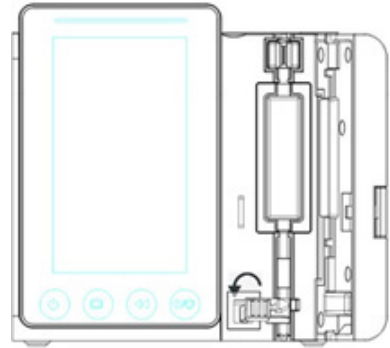

2. Push the anti-flow free clip to the lower

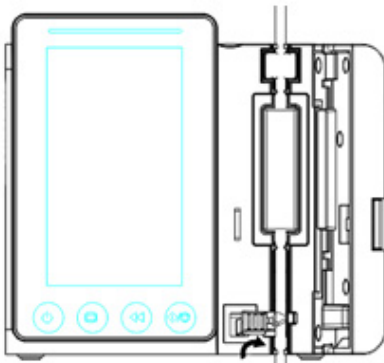

3. Gently pull the infusion tube, straighten it, and fix the infusion tubing the tube groove at both ends from top to bottom, and close the anti- free flow clip to clamp the infusion tube.

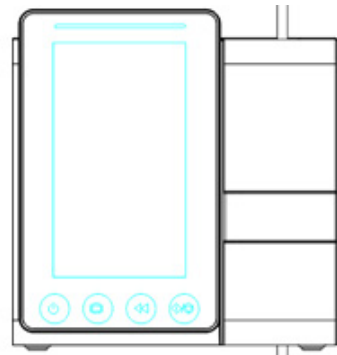

4. Close the pump door, then pop up the infusion tube selection interface, indicating that the infusion tube is installed correctly. Otherwise, you need to reinstall

Warnings: 

- It is recommended to use the infusion set built into the system.
- Please confirm the infusion set brand specifications displayed on the touch screen, which is consistent with the actual use.
- Although the device supports the calibration of the customized infusion set, to ensure the accuracy of the infusion, it is strongly recommended that the user contact the company for IV set calibrated and tested by the company's professionals.

» 6.2.3 Replace Infusion Line/Infusion Container

- Please replace the infusion tube assembly according to the following steps:
 - Close the flow rate adjuster of the infusion tube assembly, open the infusion pump door, and then remove the infusion tube assembly.
 - According to the manual Chapter 6.2.2, prefill and install the new infusion tube assembly.
 - Operate to restart infusion according to the above infusion steps if needed.
- Please replace the fluid/drug container according to the following steps:
 - Close the flow rate adjuster of the infusion tube assembly.
 - Remove the fluid/drug container from the infusion tube assembly.
 - Connect the infusion tube with the new fluid/drug container.
 - Restart infusion according to the above steps of replacing infusion tube assembly.



Warning : The infusion tube would distort if it worked for a long period and may result in flow rate error, it is suggested to replace the pump pressing position or infusion tube assembly after working for 8h.

» 6.2.4 Selecting the infusion set brand

In the infusion tube selection interface, click on the currently used infusion set brand. See 7.1.13 brand for specific brands.

Warning: 

If using a non- built-in infusion set, please confirm the relevant infusion performance (accuracy, air bubble, pressure) on the infusion pump before confirming the use, otherwise the infusion will not be guaranteed.

» 6.2.5 Set infusion mode

Enter the **Modes** interface, select infusion mode, then set infusion parameters.

■ ml/h mode

Under this mode, it allows to set three parameters: Rate, VTBI (Volume to be infused) and Time, set any two of the three parameters, and the system will automatically calculate the third parameter, if the VTBI is 0, then the equipment works at the set rate till stop with alarm.

■ Body-weight mode

Under this mode, set the Weight(body weight), Acti agentia(drug mass), Conc.unit(concentration unit), Volume(fluid volume), Dose rate, Dose unit, VTBI.

The system will automatically calculate the flow rate from the specified dose rate (ug/kg/min, mg/kg/min, ug/kg/h, mg/kg/h,...etc) according to related formula $\{\text{dose rate} \times \text{weight}\} / \{\text{Acti agentia}(\text{drug mass}) / \text{Volume}(\text{fluid volume})\}$, and automatically calculate the time according to (VTBI) / (flow rate).

■ Drip mode

Under this mode, set the VTBI and drop rate, and the system will automatically calculate the infusion flow rate and time.

 **Note:** The flow rate under drip mode is calculated according to the specification of the current infusion apparatus, before adopting the drip mode, please confirm that the specification of the current infusion apparatus is accordant with the specification displayed in the interface title bar display, if it is not accordant, please contact the equipment maintenance technician to modify, otherwise, it may cause serious deviation of flow rate.

■ Drug library mode

None means that the drug library mode is turned off. Click on the drug name and follow the instructions to enter the infusion parameters.

DERS is suitable for this mode and the drug dose rate will be limited. If the cumulative dose exceeds the preset dose limit for a certain period, the “drug dose overrun” alarm will be triggered.

 **Note:** This device supports customized drug information editing functions. Please contact the licensor if necessary.

■ Sequence Mode

Sequence mode means to infusion according to the set sequence after setting the rate and time of different sequence groups. At most 5 sequences can be set in this mode.

» 6.2.6 Purge Air

To prevent air from entering the body, the air bubbles in the infusion set must be removed before infusion. Under the parameters setting interface, short press **Bolus** button to enter the exhaust interface, and exhaust according to the interface instructions to clear the bubbles in the infusion line . The purge total volume is not calculated in the Total Volume Infused.

 **Cautions:** Before purge air, pls. confirm the infusion line is **not connected** with the animal.

» 6.2.7 Set the infusion parameters

In each infusion mode, the user sets the infusion parameters through the touch screen. For the setting range of the infusion parameters, see 2.5 Product Specification.

» 6.2.8 Setting up heater function

EN-V5 Vet supports liquid heater, and the heater parameters must be set first. For details on setting the heater parameter range, please refer to chapter 2.5.

1. Select **Modes** on the main interface and click **Heater** at the top of the “ml/h Mode” or “Body-weight Mode” interface to enter the heater switch selection interface. Users can set **Heater Switch** and **Heater temperature** through the touch screen.

2. The heater function is available only when AC is plugged in. DC and battery power do not have the heater function.

» 9.2.9 Start infusion

Connect IV tube with animal, confirm infusion parameters, Press **Start** button, start infusion.

» 6.2.10 Changing infusing parameters during infusion

During the infusion process, click the flow rate value on the running interface to reset the flow rate. After confirmation, click  to continue the infusion.

 **Note:** Sequence mode does not support changing the flow rate during infusion.

» 6.2.11 Bolus

In operation, Bolus functions have two operation modes: Manual bolus and Automatic bolus, Bolus volume is included in the total amount of infusion.

■ **Manual Bolus:** Short press the **Bolus** button to enter the fast forward infusion setting interface, set the fast infusion speed, Long press the **Bolus** button to fast forward the infusion, and release the button to the original rate infusion.

■ **Automatic Bolus:** Short press the **Bolus** button to set any two parameters of the preset amount, speed and time of the fast-forward infusion. Click the bottom-line **Start**. After the Bolus set volume is completed, the device reuse the original infusion rate. If you want to end the fast-forward infusion early, press the **Bolu** button.

Notas:

-  - The "VTBI near end" alarms are not triggered during Bolus.
- The pressure level is adjusted to the highest-level during Bolus to avoid false alarms.

» 6.2.12 Infusion Completionn

When infusion near completion, pump will alarm. If ignore it, the system will keep alarming until finishing infusion.

After VTBI completed, it activates VTBI infused alarm, if KVO function is ON, the equipment automatically starts KVO function, click  in the alarm interface to stop KVO and eliminate alarm.

The default working time of the KVO system is 30min, after reaching the time, it will activate KVO completion alarm and stop infusion.

Please refer Chapter7.1.2 to set KVO rate.

» 6.2.13 Stop Infusion

During infusion or after infusion, click **Stop**, infusion stop. The interface display Total Volume Infused and adjustable parameters.

» 6.2.14 Remove IV set

Disconnect the infusion set from the animal. After opening the pump door, push the button to the lower left to remove the infusion set.

» 6.2.15 Power off or Standby

Method 1: hold the  Button till the screen is OFF, the equipment is OFF.

Method 2: press the  Button to enter OFF interface.

1. Turn off the equipment: click **Power off** icon, the equipment is turned OFF.

2. Standby: click **Standby** icon to enter standby time setting interface, set the standby time.

Standby time range: 1min - 99hrs59min

Under standby state, the screen brightness will be lowest, after standby, the screen brightness will be recovered.

3. Cancel: click **Cancel**, return to the interface before OFF setting.

4. If no operation, the device will enter standby interface automatically.

 **Note:** The equipment has standby function only under the non-working state.

CHAPTER 7, SYSTEM SETTING

7.1 Settings

Click **Settings** icon in the main interface to enter parameters setting interface.

» 7.1.1 Drug library

Click **Settings icon** in the main interface to enter submenu, find **Drug Library** menu item, click to enter then set the ON/OFF state of drug library and view drug library information.

■ Introduction to Drug library

This device supports over 2000 drug names, which can be imported with external tools, and has functions such as upper and lower limit, concentration and so on.

Select drug and then import the drug parameters, the user may change the parameters including the concentration and dosage rate, but the parameters won't be saved.

■ Setting Drug library

After the drug library function is turned on, the infusion pump correctly installs the infusion tube and selects the infusion set brand. In the pop-up drug information selection interface, click the preset drug name. The selected drug will be displayed in the infusion mode parameter.

» 7.1.2 KVO rate

Click **KVO rate**, input the numerical value, after confirming, click . Please refer to Chapter 2.5 for the adjustable KVO range.

 Note: KVO will be closed if KVO rate is 0ml/h.

» 7.1.3 Bolus rate

Click **Bolus rate**, input the numerical value, after confirming, click . Please refer to Chapter 2.5 for the adjustable Bolus rate range.

» 7.1.4 Occlusion Pressure

Click **Occlusion pressure** to enter occlusion pressure level setting interface, move the long box to the preset level, after confirming, click .

The higher the chosen click level, the higher the occlusion level, it is suggested to select suitable occlusion pressure according to actual requirement.

DPS is turned on by default, and the line pressure is graphically and dynamically visible during infusing status.

Warnings 

■ When adopting fluid/drug of high viscosity and the occlusion pressure is set at low level, it is possible that the system will report occlusion alarm even when the line is not obstructed, under this condition, please carefully observe the pressure indication icon in the display screen and infusion line and rise the occlusion pressure if needed.

■ When the occlusion pressure is set at high level, it may possibly cause the animal to be uncomfortable. After raising the occlusion pressure, please carefully observe the condition of the animal, and

immediately take measures if there's any abnormality.

■ Under the equipment fault state, the max pressure generated by the infusion line is 1500mmHg. Under single fault state, the max infusion volume is 2ml.

■ If not used for intravenous infusion, for example Intra-arterial infusion, TPN (Total Parenteral Nutrition) or EN (Enteral Nutrition) treatment, occlusion level should be adjusted to higher levels.

Note: 

The lowest pressure (50mmHg) limits the flow rate to $\leq 100\text{ml/h}$, and the remaining 2-5 levels have no flow rate limit.

When the line occlusion activates occlusion alarm, the system will automatically trigger anti-bolus function to drop the line pressure and avoid additional impact bolus to the animal after contacting the occlusion. Liquid leakage will be less than 0.2ml, line pressure will be less than 300mmHg.

» 7.1.5 Bubble detecting level

Click **Bubbles size** to enter air bubble size setting interface, move the long box to the preset level, confirm and then click .

The bubble sensitivity is $20\mu\text{l}$.

Single bubble detection: A single bubble alarm is triggered when the individual bubble volume of the infusion tube reaches the preset bubble detection alarm threshold. The individual bubble detection levels are detailed in the table below:

Standard software		Optional software	
Air Bubble detector level	Alarm Threshold Value	Air Bubble detector level	Alarm Threshold Value
Level 1	$50\mu\text{l}$	Level 1	$20\mu\text{l}$
Level 2	$100\mu\text{l}$	Level 2	$50\mu\text{l}$
Level 3	$200\mu\text{l}$	Level 3	$100\mu\text{l}$
Level 4	$400\mu\text{l}$	Level 4	$200\mu\text{l}$
Level 5	$800\mu\text{l}$	Level 5	$400\mu\text{l}$
		Level 6	$800\mu\text{l}$

» 7.1.6 Cumulative Bubble

Click **Cumulative Bubble** to enter the interface of accumulative bubble setting, input the threshold value of accumulative alarm, and click  to confirm.

The accumulated bubble detection range is $50 \sim 1000\mu\text{l}/15\text{min}$. When the volume of cumulative bubbles within 15min reach the preset alarm threshold, the accumulative bubble alarm is triggered. It is recommended to set the cumulative bubble detection range according to actual needs.

» 7.1.7 Finish Pre-Alarm

Time for pre-alarm refers to the time of activating nearing completion alarm when the fluid/drug infused volume is nearly reaching the preset value.

Click **Finish pre-alarm** to enter the time for pre-alarm setting interface, select ON or OFF, click the preset time option, then the corresponding icon of this option changes into .

The adjustable range of time for pre-alarm is: 2min, 5min, 10min, 15min, 20min, 30min.

» 7.1.8 Reminder alarm

Click **Reminder alarm** to enter the time for reminder alarm setting interface, select ON or OFF, click the preset time option, then the corresponding icon of this option changes into . The adjustable range of time for Reminder alarm is: 2min, 5min, 10min, 15min, 20min, 30min.

Reminder alarm means that the system will activate "Reminder alarm" if no button is operated within the preset time for "Reminder alarm" when the equipment is under no infusion no alarm state.

» 7.1.9 Weight unit

Click **Weight unit** to enter the body weight unit setting interface, click preset body weight unit option, then the corresponding icon of this option changes into .

 Note: The current software version only support unit kg.

» 7.1.10 Pressure Unit

Click **Pressure unit** to enter pressure unit select setting interface, four units are available: mmHg, kPa, bar, psi, click the preset unit option.

 Note: Please carefully confirm when changing the current pressure unit.

Unit Mark	Unit Conversion
kPa	1 kPa=7,5mmHg=0,145psi=0,01bar
PSI	1psi=51.724mmHg=6.897kpa=0.069bar
Bar	1bar=750mmHg=14.5psi=100kPa

» 7.1.11 Micro Mode

Click **Micro mode** to select the micro mode to be turned on and off. Under the ON mode, the infusion rate under any infusion mode is not allowed to exceed this limit.

Micro mode speed limit setting: Click **System - Maintenance** - enter password 2341 - **Micro mode setting** to enter the micro mode speed limit setting interface.

 Warning: Speed setting requires department head nurse authority.

» 7.1.12 Drop Sensor

Click **Drop sensor** to set ON or OFF.

The “Drop error” alarm function is only available only when the drop sensor is installed.



Note: The default state for drop sensor function system is OFF, it can be manually turned on by the user when the drop sensor should be adopted. If the function is ON when the drop sensor is not installed, then the system will report “drop sensor connection” alarm.

» 7.1.13 Tube brand

For the built-in infusion apparatus brand of the system, after installing the infusion apparatus, click **Commonly used tube brand** to enter the infusion apparatus brand selecting interface, and click the preset brand option.

For blood infusion, a disposable blood infusion set in accordance with ISO 1135-4 is recommended.



Note: The infusion apparatus of different brand may possibly cause flow rate deviation, when use, please confirm if the displayed information in the interface is accordant with the actual working infusion apparatus.

» 7.2.14 Heater Calibration

For heater parameters, refer to chapter 2.5. Calibration steps:

1. Install the heater as required; (see 4.2.3)
2. Press **Menu** to enter the main interface, enter **System**, click **Maintenance**, enter password 2341, click **Sensor Calibration**, enter password 1688, and select **Heater Calibration**.
3. Use a thermometer to measure the actual temperature of the heater NTC.
4. Click **External measured T**, enter the measured temperature value to complete the calibration.

7.2 General

In the main interface, click **General** to enter the equipment setting interface.

» 7.2.1 Network

This equipment supports wireless or wire interconnection, when it is equipped with wireless module and connects with the internet through WIFI, the equipment screen displays  icon. Click **Network** in main interface to set the response.

Notes: 

- This function shall be set by the professional equipment maintenance technician.
- After activating the interconnection function, the equipment can periodically transmit the equipment data to outside, and the data is only for displaying and doesn't provide any suggestion on therapy.

■ Connection Mode

The connection mode supports WLAN modes.

■ WLAN

When WIFI function is in use, turn on the WLAN switch of the equipment, set the name and password of access point, and configure the TCP/IP parameters.

Notes: 

- The wireless access must be set by the professional technician.
- The transmitted data of this equipment doesn't provide any suggestion on therapy, and this data shall not be used for calculating the therapeutic schedule.
- When the data is adopted by the third party's equipment or software, it is only for displaying and shall not be used for alarm or calculating.

» 7.2.2 Sound

Click **Sound** to enter the sound parameters setting interface, the volume has 10 levels. The lowest volume is ≥ 80 dB, and the highest volume is ≤ 80 dB. Move the long box to the preset level, after confirming, click 

» 7.2.3 Date &Time

Click **Date &Time** to enter the date and time setting interface. It allows you to set the date, time and format in this interface.

When setting date and time, directly input the numerical value in the input method interface. For example, to preset one date "2015-08-31", input "20150831"; to preset the time "13: 34", input "1334". The time is displayed in 24h format or 12h format, the date is displayed in British type, American type or Chinese type, please set according to the requirement.

» 7.2.4 Screen Lock

Click **Screen lock** to enter automatic lock screen setting interface, select ON or OFF.

Automatic lock screen time can be set at 15s, 30s, 1min, 2min, 5min, 10minor 30min and so on, which means that the equipment will automatically lock the screen if it is not touched, or the button is pressed within corresponding time after starting. If the screen or keypad is locked, no operation can be conducted. After turning on **Screen lock** function during infusing, press **Power** key to lock or unlock the device manually.

Unlock: press any keypad, or click the screen, a reminder of unlock will be popped out, click 



Note: The equipment will automatically unlock if there is high Level alarm.

» 7.2.5 Brightness

Click **Brightness** to enter display brightness setting interface. The brightness has 10 levels.

» 7.2.6 Night mode

Click **Night mode** to enter night mode switch setting interface to set the start and end time of the night mode and the night brightness, at night, the system automatically adjusts the brightness to the User defined value.

» 7.2.7 Nurse call

Click **Nurse call** to select function ON and OFF.

Notes: 

- The nurse call function must be used with special cable.
- The user shall not only depend on the nurse call function as the main alarm notice mode and shall identify according to the equipment alarm and the animal state.

» 7.2.8 Nurse call Alarm Level

Click **nurse call alarm level** to select different alarm levels.

» 7.2.9 Battery Capacity Display

Display of battery capacity under h:m or percentage status can be switched and title bar display changes accordingly.

7.3 Patient

Click **Patient** in the main interface to enter setting interface.

» 7.3.1 Patient Information

Click **Patient** to enter the patient information setting interface and set bed number, MRN, name, gender, age, body weight, height.

7.4 Records

Click **Records** in the main interface to enter setting interface.

» 7.4.1 History entries

Click **Records** in the main interface to enter submenu, click the **History entries** menu item into history records query interface. The equipment supports to save over 5000 history records, and can display the event name, event date and time. When it is full, the new records will cover the old records by turn. The history record contains alarm information, treatment records and exhaust, cumulating clear, switch, standby operation information

» 7.4.2 Last therapies

Click **Records** in the main interface to enter submenu, click the “Last therapies” menu item into medical records query interface.

1. This interface displays the latest 20 medical records, user may directly select it as the current infusion plan, after confirming the parameters, then start infusion.
2. The system can save 20 medical records at most; when it is full, the new records will cover the old records in turn.

» 7.4.3 Export history records

Log on to the PC tool to connect this equipment with PC.

After the equipment has achieved communication with PC, the PC can automatically read the data in this equipment.

Create the history record folder in the PC to export the data to the folder.



Note: Please do not export data when the equipment is working.

7.5 System

Click **System** under the menu interface, enter the system information setting interface.

» 7.5.1 Language

This equipment supports simplified Chinese, English, etc. Click **Language** to change device language.

» 7.5.2 SN (Serial Number)

Check the serial number of the equipment, and user can't modify the serial number.

» 7.5.3 Version

Check the software version in this interface.

7.6 Reset Total Volume

In the ml/h mode setting interface, **Click Reset total volume**, the interface displays the operation confirming prompt box, click to confirm reset, otherwise, please click 

Click the **Volume** in the running interface during the infusion. the interface displays the operation confirming prompt box, click to confirm reset, otherwise, please click 

7.7 Electronic Memory Function

After the device is turned off or loses all power, the history and alarm settings of the device storage are not affected, and the electronic memory function is saved for not less than 10 years.

When the power failure time is ≤ 30 s, the alarm setting before power failure will be automatically recovered.



CHAPTER 8, ALARM PROMPT AND TROUBLESHOOTING

8.1 Introduction to Alarm Level

During infusion preparation and infusion, this equipment will alarm when reaching or exceeding the set alarm threshold value and prompt with sound, light and text. According to the importance of alarm information as well as the emergency and safety, the alarm is divided into three levels: high, medium and low. Please refer to table below for details:

Table 8.1-1

Alarm Level	Sound Signal Interval	Sound Signal	Light color / flash frequency	Duty cycle
High alarm	8s	Di di di di di, Di di di di di	Red indicator flashes / 2,0±0,6Hz	20%-60%
Medium alarm	15s	Di di di	Yellow indicator flashes / 0,6±0,2Hz	20%-60%
Low alarm	25s	Di di di	Yellow indicator lights on	100%

If there's alarm, the system will display the alarm interface. Click  to exit the alarm interface. Click  to mute, if alarm is not eliminated, the alarm sound will be sent out 2min later.

ALARM SIGNAL sound pressure level range:

50dB(A) ≤ the LOW PRIORITY auditory ALARM SIGNALS ≤ the MEDIUM PRIORITY auditory ALARM SIGNALS ≤ the HIGH PRIORITY auditory ALARM SIGNALS ≤ 80dB(A)

Warning: 

- Some alarm thresholds of this device can be set by the user without password protection restrictions: occlusion pressure and Standby time, the user shall confirm the parameters when set the alarm threshold value, otherwise, it may possibly influence the alarm function or infusion safety.
- This alarm system is provided with an OPERATOR ALARM SYSTEM log. When the equipment is powered off, the alarm system records "shutdown" in the log and records the power off time in the log.
- After the alarm system is completely powered off within a certain period (power supply and/or internal power supply), press the shutdown button and the alarm system will record "manual shutdown" in the log. After the battery is consumed to the limit, the alarm system will record "automatic shutdown" in the log and record the power off time in the log.

8.2 Multi-level Alarm Rules

When there're several alarms, the system will alarm according to the following rules:

Table 8.2-1

Multilevel Alarm	Rules
Several alarms of different levels generate simultaneously	Display the alarms of highest level with sound, light and text, report medium alarm after eliminating all alarms of highest level
Several alarms of same level generate simultaneously	Alarm circularly by turns, the time interval is 3s

8.3 Alarm Handle



Warning: When there's alarm, please check the conditions of the animal, remove the reason of alarm and then continue working.

Please refer to Appendix C for the alarm solution.

8.4 Fault Analysis and Solution

When there's fault, the infusion pump screen will display the fault alarm information, this item is the alarm of high level. Please eliminate the fault alarm according to the prompt. If it can't be eliminated, please stop the equipment, contact our company to repair and test the equipment, do not put it into operation before the equipment has passed the inspection, otherwise, it may possibly cause unpredictable harm if it works with fault.

If the equipment is on fire/burns for unknown reason, or has other abnormal conditions, the user shall immediately cut off power supply and contact our customer service department.

- Under single fault state, the max infusion volume is 2ml.

Notes: 

- The distance between the operator of the infusion pump and the pump should not exceed 0.5m, so as not to affect the operator to correctly identify the alarm.

- The visual alarm signal is 4 meters away, the alarm indicator or analog alarm indication area is visible to the naked eye; the visual alarm information is 1 meter away, and the alarm text or alarm icon is visible to the naked eye.

CHAPTER 9, MAINTENANCE

9.1 Cleaning, disinfecting and sterilizing

Warning 

- Please cut off power supply and unplug the AC/DC power wire before cleaning the equipment.
- During cleaning and disinfecting, please keep the equipment horizontal and upwards to protect the equipment and accessories from fluid.

» 9.1.1 Cleaning

1 The daily maintenance is mainly to clean the housing and pump body. It is inevitable that fluid/drug may flow in the equipment during infusion. Some fluid drug may corrode the pump and cause working fault. After infusion, please timely clean the equipment, wipe it with moist and clean, soft fabric, and then naturally dry it.

2 When cleaning the equipment interface, please wipe it with dry and soft fabric, confirm the interface is dry before use.

3 Please do not soak the equipment in water. Although this equipment has certain waterproof function, when fluid splashes on the equipment, please check if it works normally, perform insulation and electric leakage test if needed.

» 9.1.2 Disinfecting

1. Disinfecting may possibly cause harm to a certain degree to the equipment, it is suggested to disinfect the equipment if it is needed.

Please disinfect the equipment with common disinfecting agents such as 70% ethanol, 70% isopropyl alcohol and so on. Please follow the instructions of the disinfecting agent.

2. After disinfecting, wet the soft fabric with warm water, dry the fabric and then wipe the equipment with it.

3. Do not sterilize the equipment with high pressure steam sterilizer, do not dry the equipment with dryer or similar product.



Warning : Please do not adopt Cidex OPA orthophthalaldehyde, methyl ethyl ketone or similar solvent, otherwise, it may corrode the equipment.

9.2 Periodical maintenance

Notes: 

- The medical mechanism shall set up complete maintenance plan, otherwise, it may possibly cause the equipment to malfunction or fault and may possibly hurt the physical safety.
- To ensure safe use and prolong the service life of the equipment, it is suggested to periodically maintain and check it once every 6 months. Some items shall be maintained by the user, and some items shall be maintained by the dealer of the equipment.
- Please timely contact our company if the equipment is found defective.

» 9.2.1 Check the Appearance

1. The appearance of the equipment shall be clean and in good condition without cracks and water leakage.
2. The buttons are flexible and effective without invalid phenomenon; the sensitivity of the touch screen is normal.
- 3 The infusion pump door can be smoothly opened and closed; the safety clamp switch is in good condition.
4. The power wire is in good condition and installed tightly.
5. After connecting with external power supply, check whether the AC and DC indicators of the device and the battery indicator are lit normally.
6. Adopt the accessories designated by our company.
7. The environment meets the requirements.

» 9.2.2 Performance Check

Self-test and normal infusion function.

Alarm function normal

Battery performance.

» 9.2.3 Maintenance Plan

The following check/maintenance items must be performed by the professional technician recognized by our company. If the following maintenance is necessary, please contact our company. Please clean and disinfect the equipment before testing or maintaining.

Maintenance Items	Cycle
Safety check according to IEC 60601-1	Once every 2 years, please check after replacing the printed circuit board assembly or the equipment is dropped or knocked.
Preventive system maintenance items (pressure calibrate, sensor calibrate, pump)	Once every 2 years, when the occlusion alarm, air bubble alarm, or infusion accuracy is doubted to be abnormal
Brand of user-defined infusion apparatus, infusion accuracy calibration	Using the equipment for the first time, infusion apparatus brand using for the first time, reusing the equipment after stopping for a very long period.

9.3 Add new brand and Calibration

In the **System** submenu, click **maintenance** to enter brand setting interface, create the consumables brand, delete and calibrate the brand.



Warning: It is suggested to contact our company or local dealer, and customize and calibrate it by professional technician, otherwise, it can't guarantee the infusion accuracy.



Note: The built-in brand of the system shall not be deleted.

1. Add new brand



Note: If the actual using infusion apparatus brand is not listed in the system built-in brand, please create the infusion apparatus brand in this interface.

Click **Add new brand** to enter the new brand interface, edit infusion set brand name, specifications and other information.

2. Delete

Enter **Delete** interface, click it to delete user-defined infusion apparatus brand.

3. Calibre



Note

- When first time use pump need calibration.
- When added new brand need calibration.
- When accuracy is not good needs calibration.

Please calibrate the infusion apparatus when using the built-in brand infusion apparatus for the first time, or the first user-defined infusion apparatus brand, or after periodical maintenance.

Please prepare the following materials before calibrating:

One new and unused infusion apparatus, scale balance, 50ml measuring cup.

Calibrating Steps:

1. Select the brand name
2. Install the IV tube
3. Press **Bolus** to remove air bubble in the line, put the needle into the measuring cup for collecting fluid
4. Click **Start Calibrate** to start Calibrate
5. After 3 min, the equipment will automatically stop, then record the net weight of fluid by ml
6. Click **Volume**, Input the net weight(ml)
7. Calibration completed

Note 

When the **Volume** is less than 10ml, the infusion rate is $\leq 1500\text{ml} / \text{h}$.

When the **Volume** is less than 7.5ml, the infusion rate is $\leq 1200\text{ml} / \text{h}$.

9.4 Repair

Warning: The maintenance of the equipment and the replacement of the components shall be carried out by professionals recognized by the company. Special attention shall be paid to the detection of the power supply when the power module is replaced. Observe whether there is a false alarm, connect the AC power supply, and the battery is charged normally.

» 9.4.1 Normal Repair Process

Please contact our company or authorized service personnel to repair if there's any fault, do not disassemble and repair the equipment. After repair, please perform overall test for the equipment. Our company may provide the circuit diagram, and components list to the authorized repair technician if needed.

» 9.4.2 Maintenance for Long Term Store

If the equipment won't be used for a long period, please pack the equipment in the package, and store it in a shade, cool and dry place without direct sunlight.

The following operations are necessary for using it again:

1. Verify the flow rate accuracy to avoid unconformity between the infusion apparatus parameters in the equipment and the actual parameters after it hasn't be used for a long period or caused by other reasons, otherwise, it may cause infusion error, influence the therapeutic effects and even cause medical negligence.
2. Perform air bubble and occlusion alarm test.
3. Test the battery discharging and charging duration to confirm that the battery is also usable.

9.5 Equipment Components/Accessories

Warning: Only the components and accessories designated by our company shall be adopted, otherwise, it may possibly damage the equipment or drop the equipment performance.

During the normal service life of the equipment, the battery and waterproof membranes are consumables, it is suggested to replace them once every 2 years, please contact the dealer or our company to replace them.

Standard Accessories	AC Power cable
	Drop sensor
Optional Accessories	DC Power cable
	DB15 serial port communication wire
	Heater component

9.6 Production Date

Please refer to the label of the product.

9.7 Recycling

The normal service life of this equipment is 10 years and depends on the use frequency and maintenance. The equipment must be rejected after reaching the service life, please contact the manufacturer or the dealer to get more detailed information.

1. The obsolete equipment may be returned to the original dealer or manufacturer.
2. The used lithium-ion polymer battery has the same treatment method, or according to the applicable laws and regulations.
3. Please handle according to the equipment rejecting flow of your medical mechanism.

CHAPTER 10, BATTERY

This equipment is equipped with rechargeable lithium-ion polymer battery to ensure the normal infusion when the equipment is moved, or the external power supply is cut off.

When connecting external power supply, no matter if the equipment is power on or not, the battery is charged. When charging, the equipment screen displays the battery charging indication icon .

In case only built-in battery is adopted for supplying power, and when the remaining battery is less than 20%, please connect the equipment with external power supply to charge the battery.



Warning: Only the battery designated by our company shall be adopted.

10.1 Check the Battery Performance

The performance of the built-in battery may drop according to the using duration, it is suggested to check the battery once a month.

1. Disconnect the equipment from the animal and stop all infusions.
2. Supply public power to the equipment to charge the battery for 10h at least.
3. Supply power to the infusion pump only with battery, infusion at the rate of 25ml/h, test the time till the battery runs down and the equipment is turned off.
4. If the battery power supply time is significantly lower than the time stated in the specification, consider replacing the battery or contacting us.

10.2 Replaced the Battery

It is recommended to replace the battery every 2 years; it is suggested to replace the battery by the dealer or manufacturer.

Warning:



Untrained personnel are forbidden to replace the battery, otherwise it may cause the battery to burn, explode, leak and cause personal injury.

CHAPTER 11, APPENDIX

Appendix A Start Up Graphs and Trumpet Curves

■ Appendix A.1 Start-up Graphs

Sample QTY: 3 Units

IV set sample QTY: 3 Sets Flow Rate: 1ml/h

Measurement Interval: $\Delta t = 0.5\text{min}$ Measurement duration: $T = 2\text{h}$

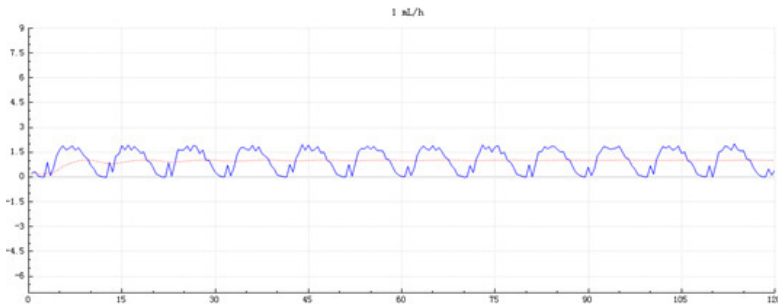

Graph 1 Start-up graph: Flow rate 1 (ml/h) against time (min) plotted from data gathered during the first 2 h of the test period

Sample QTY: 3 Units

IV set sample QTY: 3 Sets Flow Rate: 25ml/h

Measurement Interval: $\Delta t = 0.5\text{min}$ Measurement duration: $T = 2\text{h}$

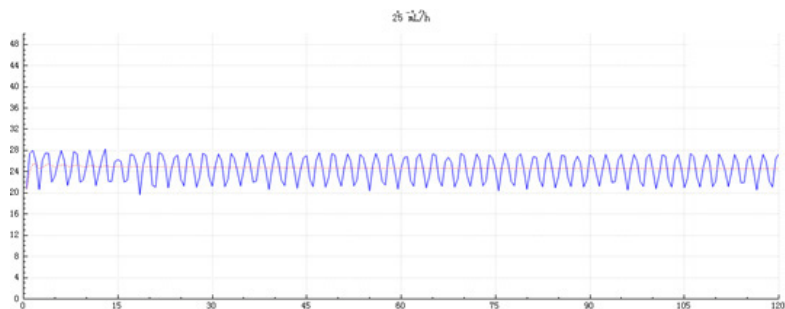

Graph 2 Start-up graph: Flow rate 25 (ml/h) against time (min) plotted from data gathered during the first 2 h of the test period

■ Appendix A.2 Trumpet Curves

Sample QTY: 3 Units

IV set sample QTY: 3 Sets Flow Rate: 1ml/h

Measurement Interval: $\Delta t = 0.5\text{min}$ Measurement duration: $T = 2\text{h}$



Graph 3 Trumpet curve: Percentage variation E_p against observation window duration P (min) and the overall mean percentage error A plotted from data gathered during the second hour of the test period

Sample QTY: 3 Units

IV set sample QTY: 3 Sets Flow Rate: 2.5ml/h

Measurement Interval: $\Delta t = 0.5\text{min}$ Measurement duration: $T = 2\text{h}$

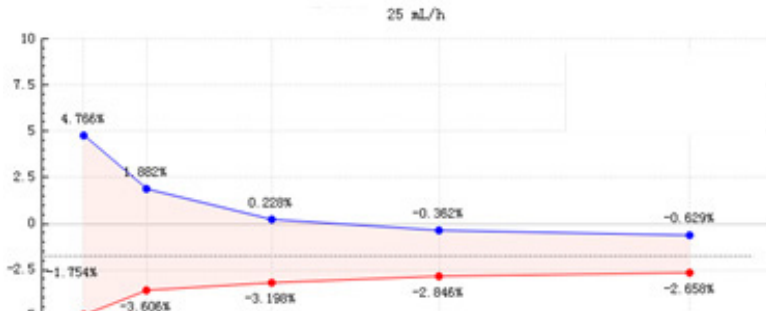

Graph 4 Trumpet curve: Percentage variation E_p against observation window duration P (min) and the overall mean percentage error A plotted from data gathered during the second hour of the test period



Note: infusion accuracy may be affected by the infusion pump environment, such as pressure, temperature, humidity, infusion consumables and so on.

Appendix B Occlusion Response Property

Occlusion Pressure (mmHg)		Flow Rate (ml/h)	Time to occlusion Alarm (h:m:s)	Max bolus (ml)
1	50	0.1	01:44:10	0.137
		1	00:10:58	0.178
		25	00:00:15	0.134
5	900	0.1	35:07:19	0.102
		1	01:50:32	0.172
		25	00:04:22	0.132



Notes:

The alarm pressure intensity error is ± 40 mmHg when the occlusion alarm level is 1.

The alarm pressure intensity error is ± 125 mmHg when the occlusion alarm level is 2-4.

The alarm pressure intensity error is ± 180 mmHg when the occlusion alarm level is 5.







Notes:

- The occlusion alarm pressure, alarm delay time and bolus are influenced by the test conditions, temperature and line length. (The increase in line length will lead to an increase of alarm delay. Lower temperature will lead to poor elasticity of pipeline, exceeding the declared error range of blocking grade, resulting in inaccurate alarm pressure. The shortening in line length and higher temperature have no effect.)

- The above data is the typical value under the test conditions, please see the test data of the product for the actual data, the data may be different if the test conditions are different

Appendix C Alarm and Solution

Alarm Type	Alarm Level	Reason	Solution
VTBI infused	High	The presetvalue infusion Completion.	Press  button to stop alarm.
Pressure high	High	1. Line occlusion during infusion.	Manually solve the problem of occlusion, Press Start button to continue infusion.
		2. Fluid/drug in the actual infusion line of high viscosity, while the system occlusion level is set too low.	Rise the alarm Level, Press Start button to restart infusion.
		3. The pressure sensor is damaged.	Please contact the dealer or manufacturer for repair
Battery empty	High	1. When power is supplied by the built-in battery only, under low battery, the alarm duration is >3min.	Immediately connect with external power supply.
		2. Battery aging or the equipment charging circuit is fault.	Please contact the dealer or manufacturer for repair.
Backup battery power exhaustion	High	1. Backup battery is nearly exhausted	Immediately connect with external power supply.
		2. Backup battery is detached or aged	Please contact the dealer or manufacturer for repair.
KVO finished	High	KVO working time reached 30min, infusion pump stops working.	Press  button to stop alarm
Single bubble	High	Air bubble in the infusion line.	Press  button to stop alarm, disconnect the line from the animal, eliminate the air with purge function, or open the infusion pump door to manually remove the air bubbles.
Cumulative Bubble	High	When the bubbles in the infusion pipeline within 15 minutes reach the cumulative bubble alarm threshold	Press  button to eliminate the alarm, separate the pipe from the animal, using the purge function to remove the bubbles, or open the door manually to remove bubbles.
Door Open	High	During infusion, the infusion pump door is opened.	Close the infusion pump door to stop this alarm.

Alarm Type	Alarm Level	Reason	Solution
Drug dose limits exceeded	High	While using drugs in drug library to infuse, alarm will be triggered if max dose in certain time have exceeded the preset limits.	Press  button to stop alarm.
System error	High	If system self-check failed or internal fault, system error alarm will give with code number.	Restart device to check whether alarm is eliminated, if still exists, contact maintenance personnel.
Temperature high	High	Detected heater temperature exceeds set temperature by 2°C	Check the temperature of the liquid in the infusion line, press the button  to eliminate the alarm
Drop error	High	The angle of inclination of the drip cup is too big or drop sensor is installed lower than the drip cup fluid level.	Check the installation of drop sensor or drip cup fluid level, Press  button to stop alarm.
		The specification of infusion apparatus is not accordant with the specification displayed in the interface, which causes drop rate error.	Check if the infusion apparatus specification is accordant with displayed parameters, if it is not accordant, it shall be modified by professional maintenance technician.
Empty bottle	High	The infusion set drip pot was detected without drops falling within the specified time.	Check if there is liquid left in the infusion bag, press  to cancel the alarm.
Occlusion pre alarm	Medium	Line pressure close to preset occlusion pressure level.	Check if there is occlusion in line and click OK to eliminate alarm.
Standby time expired	Medium	During standby, after reaching the standby time.	Press  button to alarm.
Heater failure	Medium	Fluid heater connected and during the heater process, detects no temperature increase within 5 minutes with AC plugged in or unplugged.	Restart the unit after plugging in the AC or reinstalling the heater, check if the alarm is dismissed, and if it persists, contact maintenance.
Temperature low	Medium	Detects heater temperature dropped 2°C after reaching the set temperature.	Check the temperature of the liquid in the infusion line, press the button  to eliminate the alarm
VTBI end near	Low	During infusion, the remaining time reached or is less than the set nearing completion time.	This alarm can't be eliminated, wait till infusion completes.

Alarm Type	Alarm Level	Reason	Solution
Battery nearly empty	Low	1. When power is supplied only with the built-in battery, under low battery, the alarm duration is >30min	The alarm automatically eliminates after connecting the external power supply.
		2. Battery aging or the equipment charging circuit is fault.	Please contact the dealer or manufacturer for repair.
Reminder alarm	Low	After installing infusion tube, under non-working or alarm state, it is not operated within the set time of the system.	Click any button to stop.
No power supply	Low	Under ON state, AC power supply is adopted, but the AC power wire is dropped during the process.	The alarm automatically eliminates after connecting the external power supply.
Drop sensor connection	Low	When turning on the drop sensor, the equipment is not connected with the drop sensor.	Connect the drop sensor or turn off the drop sensor in the menu.
No heater installed	Low	When turning on the heater, it detects no fluid heater present	Connect the heater, or turn it off in the menu

 Note: When alarm rings, click the **Mute** icon on the screen to temporarily stop sound alarm for 2min.

System error reference code:

System Error Name	System Error Definition
System Error 1	Main control board to monitoring board communication failure
System Error 2	Motor blocking
System Error 3	Motor reverse rotation
System Error 4	Down Pressure sensor failure
System Error 6	EEPROM failure
System Error 7	Flash failure
System Error 9	Operating system failure
System Error 10	Motor failure (The state of the motor detected by the main control board does not match the actual, the main control board let the motor rotate, but the driver board let the motor stop again)
System Error 11	Version failure
System Error 12	Air sensor failure
System Error 13	Pump body disengagement
System Error 14	Main control board/driver board reset in infusion operation state